



DEPARTMENT OF THE NAVY

OFFICER TRAINING COMMAND NEWPORT
1356 MEYERKORD AVENUE
NEWPORT, RHODE ISLAND 02841-1644

IN REPLY REFER TO:

OTCNINST 1530.6H

OCS

03 JUL 2014

OTCN INSTRUCTION 1530.6H

From: Commanding Officer, Officer Training Command Newport

Subj: OFFICER CANDIDATE REGULATIONS

1. Purpose. To provide Officer Candidates detailed regulations pertaining to their training while assigned to Officer Candidate School (OCS).

2. Cancellation. OTCNINST 1530.6G

This instruction is a complete revision and should be reviewed in its entirety.

3. Scope. Since this Officer Candidate Regulations (OCR) is limited to matters of internal organization, it shall in no way be construed as contradicting, altering, or amending the provisions of higher directives (i.e. OPNAV/SECNAV INST's).

4. Action. All Officer Candidates and Staff members are required to have a detailed knowledge of and comply with the OCR.

5. Review Responsibility. The Director, Officer Candidate School (DOCS) has overall responsibility for issuance and maintenance of the OCR. All proposed changes shall be submitted to the Director, Officer Candidate School for review.

A handwritten signature in black ink, appearing to read "K. M. McGowan", is positioned above the printed name.

K. M. MCGOWAN

TABLE OF CONTENTS

Table of Contents.....i-iv
Preface.....v-vii

**Chapter 1
Mission and Policies**

Section 1 - Mission and Navy Core Values

111. Mission Statement.....1-1
112. Oath of Office.....1-1
113. Navy Core Values and Ethos.....1-2

Section 2 - Training Policies

121. The Honor Code.....1-4
122. Attrition.....1-5
123. Drop on Request (DOR).....1-5
124. Hazing.....1-5
125. Sexual Assault.....1-6
126. Sexual Harassment.....1-8
127. Fraternalization.....1-9
128. Training Time Out.....1-9
129. Equal Opportunity (EO).....1-10
1210. Resolving Conflict.....1-12
1211. Bedrock Standards of Conduct.....1-13

**Chapter 2
Officer Candidate Organization**

Section 1 - General

211. General.....2-1
212. The Regiment.....2-3
213. OCS Class.....2-3
214. Training Phases.....2-3
215. Holding Class.....2-5
216. Medical Holding.....2-5
217. Student Pool Division.....2-6
218. Candidate Titles.....2-6

Section 2 - Billets

221. Organization.....2-7
222. General.....2-7
223. Officer Candidate Phase Billets.....2-8

3 Jul 14

224.	Candidate Officer/Applied Leadership Phase Billets.....	2-14
------	--	------

Section 3 - Watches

231.	Organization.	2-32
232.	Watch Standing Duties.....	2-32
233.	General Watch Standing Requirements.....	2-33
234.	Candidate Watches Overview.....	2-34

Chapter 3

Rights, Responsibilities, Regulations, and Procedures

Section 1 - Rights and Responsibilities

311.	Rights....	3-1
312.	Responsibilities.....	3-3

Section 2 - Regulations

321.	Gifts.....	3-4
322.	Room Regulations.....	3-4
323.	Prohibited Activities.....	3-8
324.	Personal Property.....	3-10
325.	Contraband and Health and Comfort Inspections..	3-11
326.	Leave and Liberty.....	3-13
327.	Visitors.....	3-15
328.	Physical Training.....	3-15
329.	Officer-like Qualities.....	3-18
3210.	Medical Regulations.....	3-19
3211.	Miscellaneous Regulations.....	3-23

Section 3 - Procedures

331.	Courtesies.....	3-23
332.	Formations.....	3-27
333.	Building Procedures.....	3-27
334.	Chow Hall Procedures.....	3-31
335.	Telephones/Correspondence.....	3-38
336.	Religious Services.....	3-39
337.	Medical and Dental Procedures.....	3-40
338.	Fire or Emergency Evacuation Procedures.....	3-41

Chapter 4 Conduct and Performance System

Section 1 - General

411. Standards of Conduct.....4-1

Section 2 - Basic Principles of the Conduct System

421. Honor Code Violations.....4-1

422. Attempts to Commit an Offense.....4-1

423. Knowledge, Intent, and Severity.....4-2

424. Witnessing a Delinquency.....4-2

Section 3 - The Conduct System

431. Reporting Offenses.....4-2

432. Candidate Offenses.....4-2

Section 4 - Corrective Measures

441. Demerits.....4-5

442. Recording Demerits.....4-5

443. Serving Demerits.....4-5

444. Conduct Deficient Candidates4-7

445. Extra Military Instruction (EMI)4-8

446. Performance Review Board Procedures.....4-9

Section 5 - Performance Failures

451. General.....4-10

452. Officer-like Qualities (OLQ) Failure.....4-11

453. Academic Failures.....4-11

454. Military Failure.....4-11

455. PFA Failure.....4-12

456. Swim Failure.....4-12

457. Performance Documentation.....4-12

458. Repeated Poor Performance.....4-12

459. PRT Standards.....4-13

Section 6 - Candidate Achievements

461. Class Achievements.....4-15

462. Honor Class.....4-15

463. Individual Candidate Achievements.....4-16

Chapter 5
Uniforms and Gear

Section 1 - Personal Appearance and Uniforms

511. General Requirements and Information.....5-1
512. Grooming Standards.....5-2
513. Uniform Standards.....5-4
514. Purchasing Uniform Items.....5-7

Section 2 - Uniform Components

521. Uniform Components.....5-11

Section 3 - Description and Wear of Uniform Components

531. Ownership Markings.....5-30
532. Description and Wear of Uniform Components.....5-30

Section 4 - Insignia

541. Insignia.....5-47

Section 5 - Gear

551. Unsecured Threads.....5-55
552. Miscellaneous Gear.....5-55

Appendix A Acronyms and Glossary.....A-1
Appendix B Required Knowledge for Inspections.....B-1
Appendix C Additional Information for Candidate's
Professional Development.....C-1
Appendix D Room Locker and Personnel Inspection
RequirementsD-1
Appendix E Officer Personnel Inspection
Requirements.....E-1
Appendix F 6th/9th Week Personnel Inspection
Requirements.....F-1
Appendix G Officer Candidate School Forms.....G-1
Appendix H Officer Candidate Fitness Report &
Counseling Record.....H-1

3 Jul 14

PREFACE

This instruction standardizes training regulations and procedures for Officer Candidate School (OCS). Much of the sustained superior operational execution and efficiency of the World's Greatest Navy rests upon a time-honored tradition of procedural compliance and attention to detail. It is in that tradition that compliance with this document is a requirement of all Officer Candidates. Further, you are not authorized to make copies of this publication or major portions thereof without specific authority of the Commanding Officer, Executive Officer or the Director, Officer Candidate School.

Officer Candidate School is the Navy's largest Officer Accession Program. Of all the Navy's Commissioning sources, approximately 45% of all Navy Line Officers commission annually through the doors of OCS. Officer Candidate School is an intensely rigorous 12 week program which convenes approximately 17 classes a year with up to 100 candidates per class.

SCOPE

This instruction contains information on all aspects of training at OCS and is intended to be both comprehensive and prescriptive, but it is not a substitute for sound judgment. Emergencies and other unique situations which are not clearly covered within this document, to include events that may involve the safety or property of others, may require modification of the procedures contained herein. Candidates shall read this instruction from cover to cover and are expected to have a complete knowledge of its contents.

HOW TO GET COPIES

If this instruction is not up to date with the latest changes or is missing pages, candidates should contact the Director of Officer Candidate School via their Class Officer, Lead Class Officer and Deputy Director of OCS to request an update or replacement, as appropriate.

UPDATING THE MANUAL

To ensure the manual contains the latest procedures and information, Officer Candidate Regulations review conferences are held quarterly. The result of each review conference, including a summary of submitted changes, is forwarded to the Commanding Officer. Change recommendations are submitted via

3 Jul 14

the chain of command to the DOCS on the Change Recommendation Form found in Appendix D.

CANDIDATE RESPONSIBILITY

The Officer Candidate Regulations are kept current through an active instruction change program. Any corrections, additions, or constructive suggestions for improvement of its content should be submitted at once using the procedures outlined above.

WARNINGS, CAUTIONS AND NOTES

The following definitions apply to "WARNINGS", "CAUTIONS" and "Notes" found throughout the manual.



WARNING

An operating procedure, practice, or condition, etc., which may result in injury if not carefully observed or followed.



CAUTION

An operating procedure, practice, or condition, etc., which may result in damage to equipment or property.

Note

An operating procedure, practice, or condition, etc., which is essential to emphasize.

3 Jul 14

DISTRIBUTION

The Deputy Director, Officer Candidate School is charged with the distribution and tracking of this instruction. Copies of the instruction should be distributed as follows:

Commanding Officer, OTCN	(1)
Executive Officer, OTCN	(1)
Director, Officer Candidate School (DOCS)	(1)
Deputy Director, Officer Candidate School (DPOCS)	(1)
OCS Lead Class Officer	(1)
OCS Lead Instructor	(1)
Chief Drill Instructor	(1)
Lead RDC	(1)
Class Officers (1 Each Assigned)	
Class Chief Petty Officers (1 Each Assigned)	
Class Drill Instructors (1 Each Assigned)	
Nimitz Hall Officer of the Deck (1 Each Assigned)	
Callaghan Hall Watch (1 Each Assigned)	
Officer Candidate Berthing Spaces without Laptop Computers	(2 per room)
Learning Standards Department	(4)
Safety Officer	(1)
Medical Liaison	(1)

Page Intentionally Left Blank

3 Jul 14

CHAPTER 1
MISSION AND POLICIES

SECTION 1 - MISSION

111. Mission Statement. The mission of Officer Training Command Newport (OTCN) is to morally, mentally, and physically develop future Leaders of Character and Competence - imbuing them with the highest ideals of Honor, Courage, and Commitment in order to serve as Professional Naval Officers worthy of special trust and confidence.

a. Officer Candidate School (OCS) accomplishes this mission by building the foundations of professional "OFFICERSHIP" - Leadership, Profession of Arms, Academics and Fitness.

(1) Leadership: Instilling within candidates the Qualities of a Professional Naval Officer. These qualities include Honesty/Integrity, Work Ethic, Military Bearing/Character, Dependability, Initiative, and Teamwork. Further, OCS develops Officer Candidates to perform capably under pressure and in adverse conditions while testing and strengthening their time management skills.

(2) Profession of Arms: Instilling discipline, military bearing, attention to detail, patriotism, pride, and building esprit de corps.

(3) Fitness: Instilling a "Culture of Fitness" that will endure well beyond OCS through the entirety of a career. A Professional Naval Officer must be physically strong and resilient - ready to LEAD/sustain a culture of fitness in an austere and challenging sea-duty environment.

(4) Academics: Providing candidates a fundamental knowledge of the Naval profession through classroom and practical instruction that forms the basis for their commitment to the Naval service and establishes personal standards of excellence which will remain with the graduate throughout the individual's professional career.

112. Oath of Office

I, _____, having been appointed an Ensign in the United States Navy, do hereby accept such appointment and do solemnly swear that I will Support and Defend the Constitution

3 Jul 14

of the United States against all enemies, foreign and domestic, that I will bear true faith and allegiance to the same; that I take this obligation freely, without any mental reservation or purpose of evasion, and that I will well and faithfully discharge the duties of the office on which I am about to enter. So help me God.

113. Navy Core Values and Ethos

HONOR. "I will bear true faith and allegiance..."

I am accountable for my professional and personal behavior. I will be mindful of the privilege I have to serve my fellow Americans. I will:

- Abide by an uncompromising code of integrity, taking full responsibility for my actions and keeping my word.
- Conduct myself in the highest ethical manner in relationships with seniors, peers and subordinates.
- Be honest and truthful in my dealings within and outside the Department of the Navy.
- Make honest recommendations to my seniors and peers and seek honest recommendations from junior personnel.
- Encourage new ideas and deliver bad news forthrightly.
- Fulfill my legal and ethical responsibilities in my public and personal life.

COURAGE: "I will support and defend..."

Courage is the value that gives me the moral and mental strength to do what is right, with confidence and resolution, even in the face of temptation or adversity. I will:

- Have the courage to meet the demands of my profession.
- Make decisions and act in the best interest of the Department of the Navy and the nation, without regard to personal consequences.
- Overcome all challenges while adhering to the highest standards of personal conduct and decency.

3 Jul 14

- Be loyal to my nation by ensuring the resources entrusted to me are used in an honest, careful and efficient way.

COMMITMENT: "I will well and faithfully discharge the duties..."

The day-to-day duty of every man and woman in the Department of the Navy is to join together as a team to improve the quality of our work, our people and ourselves. I will:

- Foster respect up and down the chain of command.
- Care for the personal and spiritual well-being of my people.
- Show respect toward all people without regard to race, religion or gender.
- Always strive for positive change and personal improvement.
- Exhibit the highest degree of moral character, professional excellence, quality, and competence in all that I do.

Navy Ethos:

- We are the United States Navy, our nation's sea power - ready guardians of peace, victorious in war.
- We are professional sailors and civilians - a diverse and agile force exemplifying the highest standards of service to our nation, at home and abroad, at sea and ashore.
- Integrity is the foundation of our conduct; respect for others is fundamental to our character; decisive leadership is crucial to our success.
- We are a team, disciplined and well-prepared, committed to mission accomplishment. We do not waver in our dedication and accountability to our shipmates and families.
- We are patriots, forged by the Navy's Core Values of honor, courage and commitment. In times of war and peace, our actions reflect our proud heritage and tradition.
- We defend our nation and prevail in the face of adversity with strength, determination, and dignity.
- We are the United States Navy.

3 Jul 14

SECTION 2 - TRAINING POLICIES

121. The Honor Code. **A candidate does not lie, cheat or steal, nor tolerate those who do.** This code is a practical guide for future conduct, both professional and personal. It establishes a principle of higher value than personal friendship and requires acceptance of an ideal that demands positive action in judging the conduct of another. The underlying principles of the Honor Code are the Navy Core Values of Honor, Courage and Commitment. Its objective is to inspire and encourage one to act honorably in all actions, both within and outside of the Navy establishment. Lying, cheating, stealing or tolerating any of these acts by another candidate are all violations of the Honor Code. **Violations of the Honor Code are cause for dismissal from OCS.**

a. Definitions. The following definitions are pertinent to the Honor Code:

(1) Lying. Lying is to knowingly state an oral or written untruth. A lie may be either a declarative statement or a false response to a question. It is also a lie to knowingly misrepresent the true situation or to withhold, omit or subtly word information in such a way as to leave an erroneous or false impression of the known situation. The misrepresentation may be either by word or by deed.

(2) Cheating. Cheating is knowingly violating rules or regulations. A candidate's work or performance must represent their own efforts. This is not intended to discourage assistance rendered from one candidate to another during study hours or free time to help in understanding concepts or procedures. Failing to adhere to rules and taking shortcuts of established procedures to gain an upper hand over other officer candidates in passing tests or inspections is also considered cheating.

(3) Stealing. Stealing is to wrongfully take, obtain or withhold property or anything of value from the possession of the true owner with the intention of permanently or temporarily depriving the owner of its use or possession.

b. Reporting. All Navy personnel who witness another service member commit an offense shall report the violation to the proper authority.

3 Jul 14

c. Uniform Code of Military Justice (UCMJ). All candidates upon arrival are subject to the articles of the UCMJ. The UCMJ is federal law, enacted by Congress; it is the standardized bedrock source of military law. Articles 77 through 134 of the UCMJ, known as "punitive articles" are specific offenses which, if violated, can result in punishment by courts-martial.

122. Attrition. Graduation from Officer Candidate School and earning a Commission in the United States Navy is a privilege, not a right. Candidates may be removed from training for poor performance and subsequently recommended for attrition following a Performance Review Board (PRB). Attrition recommendations will be submitted to the Commanding Officer for final disposition. Candidates may be placed in H-Class or Student Pool at the discretion of DOCS while awaiting the CO's decision.

123. Drop On Request (DOR). Candidates are enrolled in OCS on a voluntary basis; therefore, they may voluntarily request termination of their training. Anytime a candidate makes a statement such as "I quit" or "DOR", they will be immediately removed from the training environment and referred to the Class Officer. DOR is a very serious matter and should not be confused with Training Time Out (TTO).

a. If a candidate requests to DOR at any time the candidate shall be removed from the training environment and counseled by the Class Officer to determine the reasons for the DOR.

b. Candidates who DOR will immediately be removed from training. After completion of interviews with the OCS COC, the Candidate will be transferred to Student Pool.

124. Hazing

a. Definition. Hazing is defined as any conduct whereby a military member or members, regardless of service or rank, without proper authority causes another military member or members, regardless of service or rank to suffer or be exposed to any activity which is cruel, abusive, humiliating, oppressive, demeaning, or harmful. Soliciting or coercing another to perpetrate any such activity is also considered hazing. Hazing need not involve physical contact among or between military members; it can be verbal or psychological in nature. Actual or implied consent to acts of hazing does not eliminate the culpability of the perpetrator.

3 Jul 14

b. Policy. It is DON policy that:

(1) Hazing is prohibited and will not be tolerated.

(2) No service member in the DON may engage in hazing or consent to acts of hazing being committed upon them.

(3) No commander or supervisor may, by act, word, deed, or omission, condone or ignore hazing if they know or reasonably should have known that hazing may have or did occur.

(4) It is the responsibility of every service member to ensure that hazing does not occur in any form at any level. Every service member has the responsibility to make the appropriate authorities aware of each violation of this policy.

(5) Commanders or individuals in supervisory positions are responsible for ensuring that all ceremonies and initiations conducted within their organizations or commands comply with policy and participants are treated with dignity and respect during these events.

(6) Reprisal actions against any victim or witness of hazing incidents are strictly prohibited.

c. Hazing Does Not Include: Command-authorized or operational activities, required training to prepare for missions or operations, administrative corrective measures, extra military instruction, athletic events, command-authorized physical training, contests or competitions, and other similar activities that are authorized by the chain of command.

d. Reporting Requirements. Suspected incidents of hazing will be immediately reported to the Class Officer, DPOCS, DOCS or any OTCN Staff Member and will be investigated. Substantiated incidents of hazing must be reported via Operational Report to the Chief of Naval Operations or the Commandant of the Marine Corps.

125. Sexual Assault.

a. Definition. Sexual Assault is defined as intentional sexual contact characterized by the use of force, threats, intimidation, or abuse of authority or when the victim does not or cannot consent. Sexual assault includes rape, forcible sodomy (oral or anal sex), and other unwanted sexual contact

3 Jul 14

that is aggravated, abusive or wrongful (including unwanted and inappropriate sexual contact), or attempts to commit these acts. Sexual Assault crimes strike at the health, welfare and dignity of our service members and undermine the readiness of our force.

b. Policy. The goal of the Department of Defense (DoD) is a culture free of sexual assault through an environment of prevention, education and training, response capability, victim support, reporting procedures, and appropriate accountability that enhances the safety and well-being of all persons.

(1) OTCN recognizes the fundamental need to provide a confidential disclosure process for students to have access to the Restricted Reporting option throughout their training. Therefore, students will not be required to give an explanation or disclose a reason to request access to medical or see a chaplain, if they so choose.

(2) In addition, the DoD Safe Helpline is a crisis support service for victims of sexual assault providing one-on-one support by trained professionals. Candidates will have 24/7 access to this confidential and anonymous helpline through the use of a Sexual Assault Prevention and Response (SAPR) hotline phone located in the prayer/mediation room. The focus is to provide support and resources to service members as well as reinforce a culture where sexual assault is not tolerated.

c. Reporting. The Navy's SAPR Program is designed to meet the needs of the victim. There are two types of reporting options: unrestricted and restricted.

(1) Unrestricted Reporting. Allows a person who is sexually assaulted to access medical treatment and counseling, command involvement and request an official investigation of the allegation.

(2) Restricted Reporting: Allows sexual assault victims to confidentially disclose the assault to specified individuals and receive medical treatment, including emergency care, counseling, and victim advocacy, *without* triggering an official investigation or command notification. The following individuals can maintain a Restricted Report of sexual assault: Sexual Assault Response Coordinator, Victim Advocate, Medical, or Chaplain. Additionally, a close personal confidant may also maintain a restricted report as long as they are not a member of the victim's chain of command. If individuals not listed above

3 Jul 14

are told about the sexual assault, restricted reporting option cannot be guaranteed.

126. Sexual Harassment. All military and civilian personnel in the Department of the Navy (DON) have a responsibility to maintain high standards of honesty, integrity, and conduct to assure proper performance of business and to maintain public trust. Sexual harassment violates those standards, especially with regard to principles of equal opportunity. Sexual harassment is unacceptable conduct; it debilitates morale, interferes with work productivity and causes serious psychological stress to victims.

a. Definition. Sexual Harassment is a form of sexual discrimination that involves unwelcome sexual advances, requested sexual favors and any other verbal or physical conduct of a sexual nature, when:

(1) Submission to or rejection of such conduct is made either explicitly or implicitly a term or condition of a person's job, pay or career.

(2) Submission to or rejection of such conduct by a person is used as a basis for career or employment decisions affecting this person.

(3) Such conduct has the purpose or effect of interfering with an individual's performance or creating an intimidating, hostile or offensive environment.

b. Supervisors. Any person in a supervisory or command position who uses or condones implicit or explicit sexual behavior to control, influence or affect the career, pay or work of a military member or civilian employee is engaging in sexual harassment. Similarly, any military member or civilian who makes deliberate or repeated unwelcome verbal comments, gestures or physical contact of a sexual nature is also engaging in sexual harassment.

c. Acceptable Behavior. Acceptable behavior includes non-sexual touching (shaking hands, pat on the shoulder); counseling on military appearance; showing concern or encouragement; or a polite compliment or friendly conversation.

d. Unacceptable Behavior. Examples of unacceptable behavior are violating personal space; whistling; questions about personal life; repeated requests for dates; sexual favors

3 Jul 14

in return for workplace rewards; threats if sexual favors are not provided; sexually explicit pictures or remarks; using status to request dates; obscene letters, jokes, or comments; lewd or suggestive comments, touching or gestures, leering and staring; and offensive language.

e. Blatant Instances of Sexual Harassment. Blatant instances of sexual harassment, such as grabbing or threats, need not be repeated before a formal complaint can be lodged. Failure to report such behavior is a violation of the UCMJ, Article 92.

f. Reporting Requirements. Suspected incidents of sexual harassment will be immediately reported to the Class Officer, DPOCS, DOCS or any OTCN Staff Member. Substantiated incidents of sexual harassment must be reported via Operational Report to the Chief of Naval Operations or the Commandant of the Marine Corps.

127. Fraternization: The term traditionally used to identify personal relationships which contravene the customary bounds of acceptable senior-subordinate relationships. Although it has most commonly been applied to officer-enlisted relationships, fraternization also includes improper relationships and social interaction between officer members as well as between enlisted members, regardless of the service affiliation of the other officer or enlisted member, including members of foreign military services.

a. Fraternization also can occur between staff members and students.

b. Fraternization is punishable under UCMJ Article 134. All members, both senior and subordinate, are accountable for their conduct.

c. Reporting Requirements. Suspected incidents of fraternization will be immediately reported to the Class Officer, DPOCS, DOCS or any OTCN Staff Member.

128. Training Time Out (TTO). A TTO shall be called when a candidate or staff member has concern for their personal safety or the safety of another or when a candidate requests clarification of procedures or requirements. A TTO is also an appropriate means for a candidate to obtain relief if they are experiencing serious physical discomfort. Conditions that will generally trigger a TTO are chest pain, headache with blurred

3 Jul 14

vision and dizziness, difficulty breathing, or if a staff or student falls during training. Leg cramps, cramp in side, congestion or tiredness do not generally call for a TTO. Following a TTO, a staff member will clarify the situation by providing additional instruction as appropriate. TTO procedures remain in effect throughout the training day.

a. Procedure. A TTO can be requested by stating "Training Time Out", "TTO" or by displaying an appropriate hand or arm signal. When the noise level is such that words may not be easily understood, a signal such as the one used in football (making a "T" with the hands) will be used. A waving of the hands to get attention prior to giving the time out signal may also be necessary. For minor injuries or minor discomfort that DO NOT require an emergent action such as a Health Care Provider, AED (Automated External Defibrillator), CPR (Cardio-Pulmonary Resuscitation), or Base EMS (Emergency Medical Services), locate the closest staff member for assessment and follow-on directions instead of calling a TTO. Safety and well-being is our Top Priority.

b. Refusal To Train. Candidates who refuse to train after receiving training time out instruction or who use a training time out to avoid military training or reinforcement physical training (RPT) shall be removed from training and referred to the Class Officer. Refusal to train will result in a Performance Review Board (PRB). Repeatedly calling a TTO for minor reasons that are not conditions that fall within the TTO bounds will be considered a refusal to train.

129. Equal Opportunity (EO). The Navy's (EO) policy is to ensure that all employees have an equal opportunity in all aspects of employment and are free from discrimination and harassment in any form. It is expected that service members fully support a continuing commitment to exhibiting the highest professional conduct and courtesy in accomplishing its mission. It is the responsibility of every member of the Navy to ensure sexual harassment is prevented and all instances of sexual harassment are dealt with swiftly, fairly and effectively.

a. Ambiguous Situations. Ambiguous situations where intent is not clear require the perceived victim to let either the individual involved or the immediate supervisor know of the situation. The supervisor must approach the alleged perpetrator if the victim requests such action. If the problem is not resolved at this level, then formal action must be taken.

3 Jul 14

b. Discrimination Complaint (Grievance) Procedures

(1) Policy. The Navy Regulations (NAVREGS) and the Navy's EO Manual mandate that the military workplace be free from discrimination and harassment and that an environment of equal opportunity exists. Grievance procedures exist for the purpose of resolving complaints. There are two general classifications of grievances: informal and formal.

(a) Candidates who perceive they have been discriminated against and/or harassed shall attempt to resolve the complaint at the lowest level possible utilizing the chain of command.

(b) Candidates have the right to be educated on Navy's Grievance Procedures and procedures for appealing decisions.

(c) Candidates have the right to present grievances/ complaints to the command without fear of intimidation, reprisal or harassment.

(d) Candidates also have the right to communicate with the CO regarding their complaint/grievance.

(e) Candidates have the responsibility to advise the command of the specifics of the complaint and to provide the command the opportunity to rectify, remedy or take appropriate action before the complaint/grievance becomes formal and is brought to the attention of higher authorities.

(f) Candidates shall submit only legitimate grievances/complaints and exercise caution against immature or reckless charges.

(g) Candidates have the right to seek advice/assistance from the Command Managed Equal Opportunity (CMEO) Advisor and Legal Officer to resolve complaints.

(2) Informal Grievance Procedures

(a) Inform the individual.

(b) Inform the chain of command of the issue and request to contact the CMEO.

3 Jul 14

(c) Submit a special request chit for CO's Mast (Three business/working days maximum processing time).

(d) If the resolution of the informal complaint is considered unjust, use a Formal Grievance.

(3) Formal Grievance Procedures

(a) Grievances against a superior in the same command, other than the CO, are submitted per the NAVPERS 5354.2 form under NAVREGS Article 1150 using Chapter III, Manual of the Judge Advocate General (JAGMAN). Forms are available at all CMEO poster boards throughout the command.

(b) Grievances against a superior not in the chain of command, are submitted per NAVREGS Article 1150 and Chapter III of the JAGMAN.

(c) Grievances against the CO are submitted in accordance with UCMJ, Article 138 complaint using procedures in Chapter III of the JAGMAN.

(4) False Discrimination Complaints. Intentionally filing a false discrimination complaint is a violation of the USCMJ Article 107. Knowingly filing a false discrimination complaint for the purpose of harassment or embarrassment of military personnel shall not be tolerated. The Navy applies the same administrative and/or disciplinary actions to those who file false complaints as it does to those who discriminate.

1210. Resolving Conflict

a. Definition. Conflict is a disagreement between two or more people that raises serious concerns and needs to be resolved. When conflict is not resolved, serious problems may occur.

b. One of the simplest and most effective methods to resolve conflict is using the Informal Resolution System. The Informal Resolution System enables workplace conflict resolution at the lowest possible level.

c. Options to resolve conflicts include:

(1) Direct approach in writing or in person. When approaching an individual in person, use a courteous manner in trying to resolve the conflict. Do not add to the conflict by

3 Jul 14

being angry. If writing to the individual, state the facts, your feelings about the behavior and an expected resolution.

(2) Informal third party. Request assistance from another person who could serve as a mediator to help solve the conflict.

e. The Navy has formal systems in place to report and resolve cases of discrimination, harassment or other forms of inappropriate behavior if the Informal Resolution System is unsuccessful.

f. If you feel you have been a victim of discrimination, harassment or inappropriate behavior, or require assistance in using the formal resolution system, request to speak with the CMEO via your class team.

1211. Bedrock Standards of Conduct. To maintain the public's confidence in our institutional and individual integrity, all DON personnel shall:

a. Avoid any action, whether or not specifically prohibited by the rules of conduct, which might result in or reasonably be expected to create an appearance of:

- (1) Using public office for personal gain,
- (2) Giving preferential treatment to any person or entity,
- (3) Impeding government efficiency or economy,
- (4) Compromising complete independence or impartiality,
- (5) Making a government decision outside of official channels,
- (6) Adversely affecting the public's confidence in the integrity of the government.

b. Not engage in any activity or acquire or retain any financial or association interest which conflicts or appears to conflict with the public interests of the United States.

c. Not accept gratuities from DoD contractors unless specifically authorized by law or regulation.

3 Jul 14

d. Not use their official position to improperly influence any person to provide any personal benefit.

e. Not use inside information for personal gain.

f. Not wrongfully use rank, title or position for commercial purposes.

g. Not accept outside employment or activities incompatible with their duties or which may discredit the Navy.

h. Never take or use government property or services for other than officially approved purposes.

i. Not give gifts to superiors or accept them from subordinates when it is inappropriate.

j. Not conduct official business with persons whose participation in the transaction would violate a law or regulation.

k. Seek ways to promote efficiency and economy in government operations.

l. Preserve the public's confidence and trust in the Navy and its personnel.

m. Become thoroughly familiar with and support Navy Core Values.

CHAPTER 2
OFFICER CANDIDATE SCHOOL ORGANIZATION

SECTION 1 - GENERAL

211. General. Officer Candidate School (OCS) is a twelve week program where future leaders are developed through an intense program of academics, physical training, and officership development. OCS graduates and commissions approximately 1200 new Ensigns annually. The transition from civilian to Naval Officer is not one to be taken lightly. A Naval Officer is a leader who is morally, mentally, and physically sound and discharges his/her duties with the highest levels of character and competence. The highest ideals of Honor, Courage and Commitment serve as the foundation for serving as a professional Naval Officer worthy of special trust and confidence. OCS is a department within Officer Training Command Newport (OTCN). Also within OTCN is Officer Development School (ODS), Limited Duty Officer/Chief Warrant Officer School (LDO/CWO), Naval Science Institute (NSI), and Direct Commission Officer School (DCO). One of the primary goals of OCS is to develop the leadership and management skills of Officer Candidates. Throughout a candidate's training, leadership development is further achieved by assigning military responsibilities, such as watchstanding duties, to execute the school's daily operations. As with any military organization, Officer Candidates have a structured chain of command to assist in managing and maintaining the operations at OCS. The OCS organizational structure is described below:

a. Director, OCS (DOCS). The DOCS is the 6th person in a Candidate's Chain of Command. The DOCS is personally responsible for the overall operations, administration and safety of OCS. All OCS staff (including all Class Officers, RDCs, and Drill Instructors) and all OCS students report through DOCS to Commanding Officer, OTCN. DOCS is responsible for the development and monitoring of program curriculum requirements set forth in the Professional Core Competencies. The DOCS monitors student performance to ensure all requirements for graduation and commissioning are met.

b. Deputy Director, OCS (DPOCS). The DPOCS is the 5th person in a Candidate's Chain of Command and is second in OCS only to DOCS. The DPOCS oversees daily operations, administration and safety of OCS works closely with Lead RDC and Chief DI to ensure procedural compliance with this OCR and

3 Jul 14

that the high standards of OCS are enforced. The DPOCS additionally serves as the H-Class and MEDHOLD Class Officer.

c. Lead Class Officer (LCO). The LCO is the 4th person in an OCS Candidate's Chain of Command. The LCO is responsible for the execution of training, administration, discipline, conduct and general performance of assigned staff and candidates. The LCO serves as a principal assistant to DOCS and DPOCS and monitors all indoctrination week evolutions, PFAs, and Military Training Tests.

d. Class Officer. The Class Officer is the 3rd person in a Candidate's Chain of Command and is the senior member of the Class Team. The Class Officer is personally responsible and accountable for every aspect of class development; safety, training, discipline, integrity, conduct and general performance of assigned candidates from the reporting date through graduation and commissioning. The Class Officer's role and involvement is constant, but becomes most critical in the latter part of "applied leadership" training. Class Officer supervision and guidance is especially needed during Phase III of training when the Candidate Officers run the day-to-day operations of the Regiment and are preparing for graduation and commissioning. The Class Officer is responsible and accountable for the overall effectiveness and teamwork of the class team.

e. Class Chief Petty Officer (RDC). The Class RDC is the 2nd person in a Candidate's Chain of Command. RDC's shall be addressed as "Class Chief Petty Officer, Rank Last Name, USN" (i.e. Class Chief Petty Officer, Senior Chief Petty Officer Smith, USN). Candidates will respond to orders or questions with their rank (i.e. Aye-Aye Chief/Senior Chief). RDC's indoctrinate candidates in basic military procedures and adapt the students to the military lifestyle and intense environment expected during fleet assignment. RDC's instill discipline through their exemplary personal example and serve as instructors for militarization, drill, leadership, physical fitness, general military knowledge, military duties, watch standing, senior enlisted mentorship, uniform, and customs and courtesies for candidates.

f. Class Drill Instructor (DI). The Class DI is the 2nd person in a Candidate's Chain of Command. DI's shall be addressed as "Class Drill Instructor, Rank Last Name, USMC" (i.e. Class Drill Instructor, Gunnery Sergeant Smith, USMC). Candidates will respond to orders or questions with their rank (i.e. Aye-Aye Staff Sergeant/Gunnery Sergeant). DI's provide

3 Jul 14

militarization, physical fitness, and ceremonial drill training to Officer Candidates adapting them to the military lifestyle and intense environment expected during future operational assignments. Drill Instructors instill discipline through their exemplary personal example and superior military bearing.

g. Section Leader. The Section Leader is the 1st person in a Candidate's Chain of Command. The Section Leader is a member of the class and will change daily. The duties of the Section Leader are described in Section 223.

212. The Regiment. The Regiment is the Candidate Officer run Chain of Command consisting of all Officer Candidates. Indoctrination Candidates are not considered part of the Regiment until completion of First Friday.

213. The OCS Class. The candidate's organizational unit at OCS is the OCS class. Each class will be comprised of one or more companies. When candidates arrive at OCS, they are assigned to a company within the class. Completion of OCS with the initially assigned company requires the candidate to successfully complete the entire training curriculum as the company progresses through the training program.

214. Training Phases. Candidates transition through three training phases: Phase I (Indoctrination Phase), Phase II (Officer Candidate Phase), and Phase III (Candidate Officer/Applied Leadership Phase).

a. Phase I - Indoctrination Phase consists of the first three weeks of training. The first week of Indoctrination phase is Admin Week. The focus of Admin Week is to perform the majority of the administrative requirements to include medical and dental screenings, test the student's physical capabilities by administering the Initial Strength Test and to prepare the students for their endeavor to perform and graduate from the OCS program. Admin Week begins upon check-in/arrival on Sunday. During Admin Week, candidates are introduced to physical training, fitted for their initial uniform issue, and provided the basic course requirements and guidelines. During the next two weeks of Indoctrination Phase, candidates learn that motivation and drive are essential to succeed in a physically and mentally demanding training environment. Weeks two and three of Indoctrination Phase are dedicated to instructing Officer Candidates on drill, instilling military bearing and values, and placing emphasis on PT. Training and instruction in this phase culminates with the Military Training Test (MTT):

3 Jul 14

Room, Locker, and Personnel Inspection (RLP). Introduction to academics and leadership starts at the beginning of week 3 with Leadership and Management. All indoctrination training will be conducted by OCS staff with the support of the Candidate Officer Staff.

(1) Indoctrination Phase consists of the following training evolutions:

- (a) Check-in
- (b) Initial Strength Test (IST)
- (c) First Friday
- (d) Fast Cruise
- (e) Room, Locker, Personnel Inspection (RLP)
- (f) General Quarters

(2) Candidates will be referred to as Indoctrination Candidates until they have completed General Quarters.

b. Phase II - Officer Candidate Phase. Officer Candidate Phase starts the Friday of week three following General Quarters. During this phase students will be taught Leadership and Ethics, Leadership and Management, Engineering and Weapons, Naval History, Naval Orientation and Warfare, Navigation, Naval Operations and Seamanship. Candidates will also continue militarization events that instill discipline and build confidence culminating in the Capstone Event. Candidates will be referred to as Officer Candidates upon completion of General Quarters until successful completion the Capstone Event.

(1) During this phase, candidates compete for individual and company awards and class standing. At the end of the Officer Candidate Phase, candidates are selected by the Class Officer for regimental billet assignments as Candidate Officers based on their class standing.

(2) The focus in this phase of training is primarily leadership, academics and militarization. Candidates within this phase of training shall be given study hours every day of the week during the hours of 1800 - taps. The only authorized activities during study hours are:

(a) Study time related to any academic class that is part of the OCS curriculum

(b) Drill Practice until completion of Drill Competition

3 Jul 14

- (c) Regimental sweepers
- (d) Personal hygiene
- (e) Any overlapping evening chow periods
- (f) Emergencies

c. Phase III - Candidate Officer/Applied Leadership Phase. Phase III begins after 9th week Capstone Event and continues until the 12th week Graduation Ceremony. Candidates in this phase shall be referred to as Candidate Officers. The focus of this phase is to allow candidates the opportunity to apply the leadership attributes they learned during Phases I and II through the daily administration of the OCS regiment. Candidate Officers are encouraged to interact with commissioned OTCN staff in a professional manner that reflects a realistic junior-senior relationship. Interaction between OTCN senior enlisted staff and Candidate Officers should be in the spirit of mentorship to further help them transition into Junior Officers. Candidate Officers shall set the example for all other junior OCS classes.

215. Holding (H) Class. Candidates who have been removed from any phase of training for reasons involving academic or pass/fail events, temporary medical conditions, insufficient progress, disciplinary infractions, or administrative reasons may be placed in H-Class until cleared to continue training.

a. Billets. H-Class will have a President and Vice President on a permanent basis and a daily Section Leader. Only the Class Team can relieve assigned positions.

b. Re-entering Training. H-Class candidates will re-enter training as determined by the Director, Officer Candidate School (DOCS), or Deputy, Officer Candidate School (DPOCS). All candidates must take a physical fitness assessment (PFA) and obtain the minimum passing score based on the level of training they have completed prior to exiting H-Class.

c. Second PFA failures may be disenrolled.

216. Medical Holding (MEDHOLD) Class. A Candidate is assigned to MEDHOLD when expected recovery time exceeds 30 days or remaining in the OCS training environment is unsafe. Prior to exiting MEDHOLD, candidates must be cleared fit for full duty by

3 Jul 14

medical staff. If a candidate moves directly to a class, the candidate must pass a graded PFA with the minimum passing score based on the level of training they have completed. A candidate may be moved to H-Class in preparation of re-entering training as directed by the DPOCS.

217. Student Pool Division. A candidate is assigned to OTCN Student Pool Division upon removal from training or following graduation while awaiting Commissioning. The candidate will be transferred to OTCN Facilities Department until out processing is complete.

a. Removal from Candidate Status. OCS candidates classified under one of the below categories will be removed from candidate status immediately:

(1) Drop on Request (DOR). If a DOR has been requested, the individual will be interviewed by the Class Team, LCO, DPOCS, DOCS, and Executive Officer prior to the Commanding Officer's interview for final approval of the request. DORs will immediately transfer to a DOR room. Following interviews with the OCS COC the candidate will be transferred to student pool.

(2) Not Physically Qualified (NPQ). If a Candidate is determined to be NPQ, OTCN staff may pursue a medical waiver or re-designation. When a medical waiver or re-designation cannot be attained, NPQ individuals will be transferred to Student Pool.

(3) Attrition. Candidates may be removed from training for poor performance and subsequently recommended for attrition following a Performance Review Board (PRB). Attrition recommendations will be submitted to the Commanding Officer for final disposition. Candidates may be placed in H-Class or Student Pool at the discretion of DPOCS while awaiting the CO's decision. Attrition candidates will be transferred to Student Pool.

218. Candidate Titles. All students in training at OCS will be referred to only by their title and/or last name.

a. Indoctrination Candidates. Students will hold the title of Indoctrination Candidate upon check in until they have completed General Quarters.

3 Jul 14

b. Officer Candidates. Students will hold the title of Officer Candidate upon the successful completion of General Quarters until the successful completion of the Capstone Event.

c. Candidate Officers. Students will hold the title of Candidate Officer upon the successful completion of the Capstone Event until they have commissioned as Naval Officers.

SECTION 2 - BILLETS

221. Organization

a. During the Indoctrination phase, the candidate organization shown in figure 2-1, is established within the company. This organization continues throughout Officer Candidate Phase. The company is ultimately responsible to the Class Team.

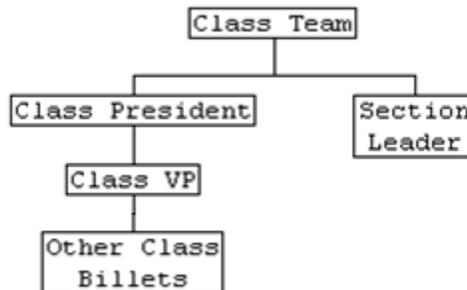

Figure 2-1

b. Candidate Officer organization and the chain of command are shown in Figure 2-2. During the Candidate Officer phase, the Class Team remains the primary liaison with the class; however, the class works with and receives guidance from the entire OCS staff.

222. General

a. Assumption of Duties. Due to the nature of training at OCS, it is sometimes necessary for leadership to be absent from the training area. It is imperative that the established chain of command remain intact at all times. Personnel assuming duties of a billet for an interim period are prohibited from establishing new or changing existing policies. They will be responsible for carrying out the formal duties and functions of their assumed positions only.

b. Delegation. Candidate Officers may, in appropriate circumstances, delegate assigned duties, however as inherent at

3 Jul 14

all echelons of command, they retain accountability for those duties.

223. Officer Candidate Phase Billets

a. Billets. There will be no billets during the first week of training. The company will decide billets after First Friday and forward their recommendation via the Team to the Class Officer for final approval. Only the Class Officer may remove a candidate from his/her billet.

(1) President. The President is selected by the company and approved by the Class Officer. The President is charged with the overall responsibility for the efficient organization, administration, and operation of the company. The President acts as the link between the Class Team and the company and is charged with reporting the daily status of the company to the Class Officer. The President is also responsible for ensuring the Section Leader is prepared to assume the duties described below. The President will ensure the Class Team is informed of any RPT supervised by any staff member other than the Class Team, and ANY RPT within the previous hour prior to drill or instructional periods.

(2) Vice President (VP). The VP is selected by the company and approved by the Class Officer. The VP is the assistant to the President and assumes the duties of the President during their absence.

(3) Adjutant. The Adjutant is selected by the company and approved by the Class Officer. The Adjutant is responsible for the administration and submission of all required reports, including the daily muster, sick call and med down reports. The Adjutant is charged with keeping up to date files including company scores on PFAs, MTTs, and Academic tests. The Adjutant will complete other administrative duties as needed or assigned.

(4) Medical Body. The Medical Body is selected by the company and approved by the Class Officer. The Medical Body will assist the Adjutant. The Medical Body is charged with keeping track of all appointments, submitting light duty/sick in quarter's chits and reporting conflicts between appointments and mandatory events. The Medical Body will complete other administrative duties as needed or assigned.

(5) First Lieutenant. The First Lieutenant is selected by the company and approved by the Class Team. The First

3 Jul 14

Lieutenant is responsible for ensuring that the cleanliness of the company spaces and adjacent passageways is maintained. The First Lieutenant will make and supervise all cleaning assignments, ensuring that assigned cleaning tasks are completed, supply lockers are clean and orderly, and all maintenance discrepancies are reported to the Class Team for action. The First Lieutenant will report to the Battalion or Regimental First Lieutenant as ordered.

(6) Watchbill Coordinator. The Watchbill Coordinator is selected by the company and approved by the Class Team. The Watchbill Coordinator is responsible for coordinating and scheduling watches stood by members of their company. The Watchbill Coordinator will also ensure that all watchstanders are qualified, have been briefed on watchstanding procedures, and report to all watches on time and in a properly maintained uniform. The Watchbill Coordinator will report to the Regimental Watchbill Coordinator as ordered.

(7) RLP/Inspection Body. The RLP/Inspection Body is selected by the Class Team. The RLP/Inspection Body is responsible for ensuring the preparedness and uniformity of the company for all inspections. All questions for the Class Team regarding inspection preparation should be directed through the RLP/Inspection Body.

(8) Drill Body. The Drill Body is selected by the Class Team. The Drill Body is responsible for reviewing drill procedures and holding extra drill practice for the company. The Drill Body must be proficient in rifle drill and marching. All questions regarding drill should be directed to the Class Drill Instructor via the Drill Body.

(9) PT Body. The PT Body is selected by the Class Team. The PT Body is responsible for ensuring that all members of the company are progressing towards achieving an improved score on the PRT. The PT Body will conduct warm-up and cool-down stretches as directed.

(10) Mail Body. The Mail Body is selected by the company and approved by the Class Team. The Mail Body shall be designated a Mail Orderly by the OTCN Mail Office. Their duties include collecting outgoing mail from members of the company and delivering it daily to the outgoing mailbox. The Mail Body will ensure that all mail incorrectly delivered to their company is returned to the outgoing mailbox.

3 Jul 14

(11) Linen Body. The Linen Body is selected by the company and approved by the Class Team. The Linen Body is responsible for collecting bed linens from members of the company on linen collection day as well as sorting, counting and delivering the linens to designated laundry pick up. The Linen Body also receives company linens from Regimental Supply on linen collection day and delivers them to the company.

(12) Conduct Body. The Conduct Body is selected by the company and approved by the Class Team. The Conduct Body is responsible for coordinating with the Regimental Conduct Officer for the completion of demerits and the tracking of all conduct deficient candidates.

(13) Treasurer. The Treasurer is selected by the company and approved by the Class Team. The Treasurer collects and accounts for all funds to pay for class emblematics, student staff challenge, pre graduation reception and other items paid for by the class.

(14) Knowledge Body. The Knowledge Body is selected by the company and approved by the Class Team. The Knowledge Body assists in forming study groups, informs the class team of academic performance, and will contact the instructor if further clarification of a subject is needed.

(15) Section Leader. The Section Leader is responsible for the daily operation and administration of the company. The Section Leader is the direct representative of the Class Team. The Section Leader is a rotating 24-hour duty that changes daily at 0500.

(a) Purpose. The Section Leader watch provides candidates an opportunity to manage people and assets and provides an important leadership development tool. All candidates shall stand Section Leader and it is important that candidates utilize this opportunity to apply and develop their leadership skills. The Section Leader will exhibit professionalism and exemplary leadership at all times. They will:

1 Lead by example.

2 Delegate authority as appropriate. (You may delegate authority, but not responsibility.)

3 Be fair, but firm.

3 Jul 14

4 Obey orders and ensure orders are obeyed.

5 Build company spirit and professionalism in all activities, particularly in professional competition.

(b) Duties and Responsibilities. Specific duties include:

1 Ensure complete compliance with the OCR.

2 Ensure communications are passed to all members of the company, whether from the Class Team or other members of the chain of command.

3 Report all RPT within the previous hour to the Class Team prior to any drill or instructional period.

4 Report any unusual occurrence (e.g. hospitalization, emergency leave, etc.) to the Class Team. In addition, reports will be made to the OCS Officer of the Deck (Nimitz Hall OOD) after normal working hours. The chain of command will be followed at all times (i.e. Section Leader, Drill Instructor/Class Chief Petty Officer, Class Officer, etc.).

5 Report the movements of the class to the Class Team as directed.

6 Know the count and location of all members of the company at all time.

7 Ensure that all reports are submitted on time and are accurate, including the following:

a Muster reports - Prior to 2200 the previous night.

b Reports required by the chain of command.

8 Ensure that the class is on time to all training evolutions.

9 Ensure that proper decorum and military bearing is maintained. Any deviation from proper military bearing will be reported to the Class Team.

3 Jul 14

10 Assist the First Lieutenant in ensuring that assigned spaces are clean.

11 Supervise candidates while marching. When going to and from class and crossing a road, post road guards prior to crossing the road.

12 Organize and supervise cleaning details.

13 Report any maintenance discrepancies (lights, plumbing, etc.) to the First Lieutenant.

14 Read the OCS Plan of the Day (POD) to the company and post on the company bulletin board.

(c) Reporting. The OCS Company Section Leader's primary reporting responsibility is to the Class Officer. When Regimental business or duties are required, the Section Leader will receive guidance and report to the Class Liaison or Battalion Sub-Commander (see Figure 2-2).

1 Indoctrination Class Section Leader. The Indoctrination Class Section Leader will report to and receive guidance from the Indoctrination Staff and the Class Team.

2 H-Class Section Leader. The H-Class Section Leader will report to the H-Class Staff Candidate Officers. The H-Class Section Leader will receive guidance from the OTCN Staff members assigned as the H-Class Team.

OCS REGIMENTAL ORGANIZATIONAL CHART

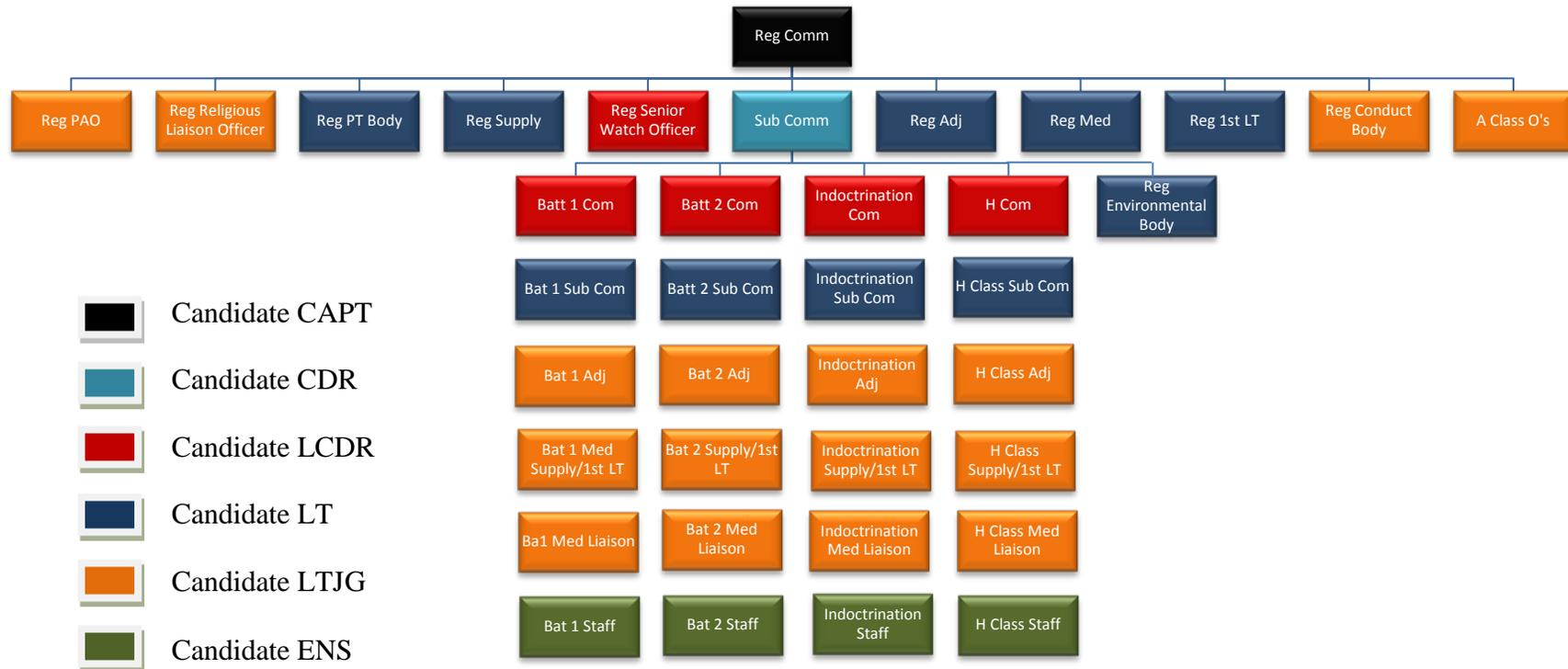

Figure 2-2

3 Jul 14

224. Candidate Officer/Applied Leadership Phase Billets

a. Assumption of Duties. During the absence of any Regimental Commander, the Sub-Commander will assume their duties. In the absence of the Sub-Commander, the Adjutant will assume those duties and so on following the organizational chart and rank structure. In all cases those duties will be assumed until relieved by competent authority.

b. Pass Down Folders. Comprehensive pass-down folders will be maintained by all Candidate Officer billet holders and will be turned over to the Candidate Officer that relieves them.

c. Execution of Duties. All billet holders on the Battalion, Indoctrination, and H-Class staffs shall report to their respective Sub-Commander for staff duties. Those candidates holding billets that have a Regimental staff counterpart will report to them for specific job responsibilities. For example, the Battalion Supply Body will report to the Regimental Supply Body for supply issues, but will report to the Battalion Sub Commander for all other duties.

d. Regimental Billets

(1) Regimental Commander. The Regimental Commander is charged with the overall responsibility for the efficient organization, administration, and operation of the Regiment. The Class Officer for the Candidate Officer Class will guide the Regimental Commander with performing their duties.

(a) Duties and Responsibilities. The Regimental Commander will:

1 Delegate duties and authority to members of the Regimental Staff and Battalion, Indoctrination and H Commander as necessary to carry out the daily routine of the Regiment.

2 Meet with the Regimental Sub-Commander, the Battalion Commanders, the Indoctrination Commander(s) and the H-Commander to prepare a list of goals to be accomplished during the Candidate Officer phase. This list will be presented to the Class Officer during the first staff meeting in the Candidate Officer phase. The Class Officer will provide guidance and recommendations on how to attain the goals.

3 Jul 14

3 Ensure all Regimental formations, drills and meetings ensuring are conducted punctually and in a military manner.

4 Maintain established standards of performance and discipline.

5 Disseminate all orders, directives and policies from higher authority to the Regiment using the proper chain of command, ensuring their prompt and efficient compliance.

6 Ensure muster reports are submitted as required.

7 Assign and revise as necessary the uniform of the day for the regiment.

8 Perform other duties as assigned.

(b) Reporting. The Regimental Commander is responsible to the Director, Officer Candidate School via the Class Officer for the daily activities of the Regiment.

(2) Regimental Sub-Commander. The Regimental Sub-Commander functions as an executive to the Regimental Commander. The Regimental Sub-Commander is specifically charged with executing the orders of the Regimental Commander and coordinating and supervising the performance and administration of the Regiment as a whole. Their duties include matters pertaining to discipline, training, drill, watches and morale (including rights and privileges) of Officer Candidates. They are responsible for the execution of the POD and all watchstanding within the Regiment.

(a) Duties and Responsibilities. The Regimental Sub-Commander will:

1 Supervise and coordinate the activities of their staff.

2 Coordinate evolutions with the Battalion Commanders and staff.

3 During the absence of the Regimental Commander, the Sub-Commander will assume the duties as acting Regimental Commander until relieved by competent authority.

3 Jul 14

4 Perform other duties as assigned.

(b) Reporting. The Regimental Sub-Commander reports to the Regimental Commander. The Regimental staff and all Battalion Commanders report to the Regimental Sub-Commander on all matters pertaining to the Regiment.

(3) Regimental Adjutant. The Regimental Adjutant functions as an executive assistant to the Regimental Commander for all evolutions and required reports.

(a) Duties and responsibilities. The Regimental Adjutant will:

1 Coordinate training evolutions within the Regiment.

2 Issue and disseminate directives and policies to the Regiment.

3 Formulate plans and schedules as required.

4 Prepare Regimental inspection schedules.

5 Report on the administrative policies and procedures of the Regiment.

6 Maintain permanent rosters of all classes and submit a daily Regimental Muster report to the Lead RDC and any other staff as directed.

7 Perform other duties as assigned.

(b) Reporting. The Regimental Adjutant reports to the Regimental Commander. All Battalion Adjutants report to the Regimental Adjutant on matters pertaining to their billet.

(4) Regimental Watch Bill Coordinator. The Regimental Watch bill Coordinator is responsible for ensuring watchstanding qualification and scheduling watches stood by the regiment.

(a) Duties and Responsibilities. The Watchbill Coordinator will:

1 Ensure all watchstanders are qualified.

3 Jul 14

2 Ensure all watchstanders have been briefed on watch standing procedures.

3 Ensure all watchstanders report to all watches on time and in a properly maintained uniform.

4 Prepare the Regimental Watchbill, submit to the OTCN Student Watchbill Coordinator for approval, and disseminate to the Regiment.

5 Perform other duties as assigned.

(b) Reporting. The Regimental Watchbill Coordinator will report to the OTCN Student Watchbill Coordinator on all matters concerning watch standing. The Regimental Watchbill Coordinator will report to the Regimental Commander for all other matters.

(5) Regimental Supply Officer. The Regimental Supply Officer is responsible for the handling and distribution of materials used by the regiment.

(a) Duties and Responsibilities. The Regimental Supply Officer will:

1 Supervise and coordinate the requisition, receipt, stowage, handling, and distribution of materials used by the Regiment.

2 Issue and receive all weapons to Candidates.

3 Generate an Armory Access List and submit weekly Armory Inventory reports to the CDI.

4 Supervise the inventory, turn-in and issue of all linens/blankets. Submit weekly linen inventory reports to the Lead RDC.

5 Account for, issue, and request requisition of replacement cleaning supplies.

6 Perform other duties as assigned.

(b) Reporting. The Regimental Supply Officer reports to the Regimental Commander. All requisitions will be submitted to and approved by the Lead Class Officer. All

3 Jul 14

Battalion Supply billets report to the Regimental Supply Officer on matters of supply.

(6) Regimental First Lieutenant. The Regimental First Lieutenant is responsible for the material condition and cleanliness of OCS regimental spaces and adjacent grounds.

(a) Duties and responsibilities. The Regimental First Lieutenant will:

1 Coordinate the Regimental cleaning bill with subordinate First Lieutenants to ensure the cleanliness and material condition of all assigned spaces and grounds.

2 Inspect all OCS spaces and grounds daily, taking corrective action when necessary.

3 Maintain a master discrepancy log and make reports to the OTCN facilities manager regarding discrepancies in the material condition of OCS spaces and grounds.

4 Assist the Regimental Supply Officer in accounting for and issuing cleaning supplies.

5 Perform other duties as assigned.

(b) Reporting. The Regimental First Lieutenant reports to the Regimental Commander. The Regimental First Lieutenant will seek guidance from and coordinate responsibilities with the OTCN Facilities Manager. Battalion First Lieutenants report to the Regimental First Lieutenant.

(7) Regimental Medical Liaison Officer. The Regimental Medical Liaison Officer is responsible for all medical requirements for students assigned to the Regiment. It is extremely important to safeguard all Personal Identifiable Information (PII) and Health Insurance Portability and Accountability Act (HIPAA).

(a) Duties and Responsibilities. The Regimental Medical Liaison Officer will:

1 Coordinate all sick call for the regiment.

2 Emergent medical needs will be immediately brought to the attention of the entire Class Team. After hours

3 Jul 14

inform the CDO. In the absence of the Class Team or CDO, notify another staff member.

3 Coordinate and manage medical appointments through the OTCN Staff Medical Liaison.

4 Perform other duties as assigned.

(b) Reporting. The Medical Liaison Officer reports to the Regimental Commander. The Battalion, Indoctrination, H-Class and OCS Class Medical Bodies will report to the Regimental Medical Liaison Officer on all matters of medical care.

(8) Regimental PT Body. The Regimental PT Body is responsible to the OCS Staff PT coordinator for all matters regarding PT.

(a) Duties and Responsibilities. The Regimental PT Body will:

1 Disseminate the PT uniform throughout the regiment per the OCS Staff PT Coordinator.

2 Set up and secure all equipment necessary for conducting morning PT.

3 Distribute and collect hand held radios to staff members.

4 Ensure first aid/AED (Automated External Defibrillator) equipment, extra canteens, and properly prepared ice buckets and sheets are available as required.

5 Ensure availability of road guards, PT vans, and PT van drivers.

6 Lead the regiment in warm up exercises.

7 Submit the PT muster to the OCS Staff PT Coordinator.

8 Ensure availability of cellphones, vests, and bull horn for staff Safety Observer/AED operators.

9 Perform other duties as assigned.

3 Jul 14

(b) Reporting. The Regimental PT body reports to the OCS staff PT coordinator on all matters regarding PT; the on-site Safety Observer for any safety related issues/concerns; and the Regimental Commander for all other matters.

(9) Regimental Religious Liaison Officer. The Regimental Religious Liaison Officer will serve as a liaison between the OTCN Chaplain and the Regiment.

(a) Duties and Responsibilities. The Religious Liaison Officer will:

1 Collect, submit, and route all special request chits through the chain of command for off-base religious services.

2 Coordinate the time and place for candidates mustering for on and off base religious services.

3 Coordinate transportation with the Regiment and CDO for off-base religious services.

4 Perform other duties as assigned.

(b) Reporting. The Regimental Religious Liaison Officer reports to the Regimental Sub-Commander.

(10) Regimental Public Affairs Officer (PAO). The regimental PAO will serve as an assistant to the OTCN staff PAO in the photo/video documentation of daily operations at OCS.

(a) Duties and Responsibilities. The Regimental PAO will:

1 Take photographs and video of OCS evolutions as directed by the OTCN staff PAO.

2 Maintain the camera check out log in the OTCN staff PAO office.

3 Distribute and collect Fleet Home Town News Release Forms for their class and turn them into the OTCN PAO for processing and release.

4 Assist the OTCN PAO on special projects and other matters regarding public affairs.

3 Jul 14

5 Perform other duties as specified.

(b) Reporting. The Regimental PAO will report to the OTCN staff PAO regarding all matters related to public affairs. The Regimental PAO will report to the Regimental Commander regarding all other matters.

(11) Regimental Conduct Body (RCB). The RCB is responsible for tracking and reporting all conduct related issues. The Conduct system from initial deficiency processing through a candidate's removal from Conduct Deficient status falls under the cognizance of the RCB.

(a) Duties and Responsibilities. The RCB will:

1 Coordinate all musters for Conduct Deficient candidates.

2 Coordinate all times allotted for the completion of demerits, to include marching tours.

3 Process Demerit Documentation forms as directed by OCS staff.

4 Execute the conduct review system as specified in Chapter 4.

5 Perform other duties as specified.

(b) Reporting. The RCB will report to the Regimental Commander. OCS Class Conduct Bodies will report to the RCB on all matters of conduct.

(12) Assistant Class Officer. The Assistant Class Officer will perform as an assistant to their assigned Class Officer and execute administrative duties pertaining to assigned classes. Assistant Class Officers will support Regimental activities whenever not otherwise directed by their assigned Class Officer. Assistant Class Officers report to their assigned Class Officer for matters regarding their billet. For all other matters they will report to the Regimental Commander.

(13) Regimental Staff. The primary job of Regimental staff is to assist the Regimental Commander in the daily operation of the Regiment. Regimental Staff report to the Regimental Sub-Commander

3 Jul 14

(14) Battalion Commander. The Battalion Commander is charged with overall responsibility for the efficient organization, administration, and operation of their Battalion. The Class Officer will guide the Battalion Commander in the execution of their duties.

(a) Duties and Responsibilities. The Battalion Commander will:

1 Delegate duties and authority to members of the Battalion staff as necessary to carry out the routine of the Battalion.

2 Ensure all Battalion formations, drills, and meetings are conducted punctually and in a military manner.

3 Maintain established standards of performance and discipline.

4 Forward recommendations to the Class Officer for disciplinary matters or meritorious comments concerning members of the Battalion.

5 Disseminate all orders, directives, and policies from higher authority to the Battalion using the proper chain of command, ensuring their prompt and efficient compliance.

6 Make frequent tours of Battalion spaces to ensure students are conducting themselves in accordance with the OCR (Officer Candidate Regulations) and other established regulations, and to ensure material conditions are maintained to a high standard.

7 Ensure Battalion muster reports are submitted as required.

8 Be thoroughly familiar with watch guides.

9 Perform other duties as assigned.

(b) Reporting. The Battalion Commander reports to the Regimental Sub-Commander.

(15) Battalion Sub-Commander. The Battalion Sub-Commander functions as an executive to the Battalion Commander. The Battalion Sub-Commander is specifically charged with

3 Jul 14

executing the orders of the Battalion Commander and with coordinating and supervising the performance and administration of the Battalion as a whole including matters pertaining to discipline, training, drill, watches, and morale (including rights and privileges) of Officer Candidates in the Battalion.

(a) Duties and Responsibilities. The Battalion Sub-Commander will:

1 Supervise and coordinate the activities of the Battalion staff.

2 Serve as Senior Watch Officer of the Battalion, provide watch bill inputs for the Battalion, and ensure proper qualification of Battalion watchstanders.

3 During the absence of the Battalion Commander, the Battalion Sub-Commander will assume the duties as acting Battalion Commander until relieved by the Battalion Commander or higher authority.

4 Perform other duties as assigned.

(b) Reporting. The Battalion Sub-Commander reports to the Battalion Commander. The Battalion staff reports to the Battalion Sub-Commander on all matters pertaining to the Battalion.

(16) Battalion Adjutant. The Battalion Adjutant functions as an executive assistant to the Battalion Sub-Commander for all evolutions and required reports.

(a) Duties and Responsibilities. The Battalion Adjutant will:

1 Coordinate training evolutions within the Battalion.

2 Issue and disseminate directives and policies to the Battalion.

3 Formulate plans and schedules.

4 Report administrative policies and procedures of the Battalion.

3 Jul 14

5 Prepare and maintain permanent battalion class rosters.

6 Perform other duties as assigned.

(b) Reporting. The Battalion Adjutant reports to the Regimental Adjutant regarding matters pertaining to their billet. The Battalion Adjutant reports to the Battalion Sub-Commander regarding all other matters.

(17) Battalion Supply Officer. The Battalion Supply Officer is responsible to the Battalion Sub-Commander for the handling and distribution materials used by the Battalion.

(a) Duties and Responsibilities. The Battalion Supply Officer will:

1 Supervise the inventory, receipt, handling, distribution, proper stowage and disposal of materials used by the Battalion.

2 Work in conjunction with the Battalion First Lieutenant.

3 Perform other duties as assigned.

(b) Reporting. The Battalion Supply Officer reports to the Regimental Supply Officer on all matters pertaining to their billet. The Battalion Supply Officer reports to the Battalion Sub-Commander regarding all other matters.

(18) Battalion First Lieutenant. The Battalion First Lieutenant is responsible for the cleanliness and material condition of Battalion spaces and adjacent areas.

(a) Duties and Responsibilities. The Battalion First Lieutenant will:

1 Coordinate and supervise Battalion cleaning bills to ensure the cleanliness and material maintenance of all assigned spaces and grounds. Supervise OCS Class First Lieutenants assigned to the Battalion in the cleaning of their assigned spaces.

2 Inspect assigned spaces daily and take corrective action when necessary.

3 Jul 14

3 Make natural condition discrepancy reports to the Regimental First Lieutenant.

4 Perform other duties as assigned.

(b) Reporting. The Battalion First Lieutenant reports to the Regimental First Lieutenant on matters pertaining to their billet. The Battalion First Lieutenant will report to the Battalion Sub-Commander on all other matters. Class First Lieutenants report to their Battalion First Lieutenant on matters of cleanliness and material condition.

(19) Battalion Staff. The primary job of the Battalion staff is to assist the Battalion Commander in the daily operation of the Battalion. This does not preclude Battalion Staff from assisting the Regimental Sub-Commander in the daily operation of the Regiment. Battalion Staff report to their Battalion Sub-Commander.

(20) Indoctrination Commander. The Indoctrination Commander is charged with overall responsibility for the efficient organization, administration, and operation of the Indoctrination Class. The Indoctrination Class Team will guide and supervise the Indoctrination Commander in the execution of their duties.

(a) Duties and Responsibilities. The Indoctrination Commander will:

1 Ensure all facilities, equipment and administrative paper work are prepared for receiving the newly arriving OCS class on check in Sunday.

2 Ensure Candidate Officers involved with the indoctrination process for the new OCS class have been properly briefed by the graduating Candidate Officers and the Indoctrination Class Team on check in procedures and proper conduct with Indoctrination Candidates.

3 Delegate duties and authority to members of the Indoctrination Staff as necessary to carry out the indoctrination routine.

4 Ensure all Indoctrination formations, drills, and meetings are conducted punctually and in a military manner.

3 Jul 14

5 Maintain established standards of performance.

6 Forward recommendations to the Class Officer for disciplinary matters or meritorious comments concerning members of the Indoctrination Class.

7 Disseminate all orders, directives and policies from higher authority to the Indoctrination class using the proper chain of command ensuring their prompt and efficient compliance.

8 Ensure muster reports are submitted as required.

9 Perform other duties as assigned.

(b) Reporting. The Indoctrination Commander reports to the Indoctrination Class Team on all matters regarding the Indoctrination Class. The Indoctrination Commander will report to the Regimental Sub-Commander on all other matters.

(21) Indoctrination Sub-Commander. The Indoctrination Sub-Commander functions as an executive to the Indoctrination Commander. The Indoctrination Sub-Commander is specifically charged with executing the orders of the Indoctrination Commander and with coordinating and supervising the performance and administration of the Indoctrination Class to include matters pertaining to discipline, training, drill, watches, and morale (including rights and privileges).

(a) Duties and Responsibilities. The Indoctrination Sub-Commander will:

1 Supervise and coordinate the activities of the Indoctrination Staff.

2 Serve as Senior Watch Officer of Indoctrination Staff.

3 Coordinate with the other Sub-Commanders and staff on matters pertaining to the Indoctrination Class.

4 Perform other duties as assigned.

3 Jul 14

(b) Reporting. The Indoctrination Sub-Commander reports to the Indoctrination Commander.

(22) Indoctrination Adjutant. The Indoctrination Adjutant functions as an executive assistant to the Indoctrination Sub-Commander for all evolutions and required reports.

(a) Duties and Responsibilities. The Indoctrination Adjutant will:

1 Coordinate training evolutions within Indoctrination Class.

2 Issue and disseminate directives and policies to the Indoctrination Class.

3 Report administrative policies and procedures of the Indoctrination Class.

4 Prepare and maintain permanent rosters of the Indoctrination Class. Supervise and coordinate the required in-processing forms and assemble individual indoctrination training records.

5 Perform other duties as assigned.

(b) Reporting. The Indoctrination Adjutant reports to the Regimental Adjutant regarding matters pertaining to their billet. The Indoctrination Adjutant reports to the Indoctrination Sub-Commander regarding all other matters.

(23) Indoctrination Supply Officer. The Indoctrination Supply Officer handles and distributes materials used by the Indoctrination Class.

(a) Duties and Responsibilities. The Indoctrination Supply Officer will:

1 Supervise and coordinate the distribution of materials used by Indoctrination Class.

2 Maintain and issue all Indoctrination Class organizational clothing.

3 Jul 14

(3) 3 Coordinate with base uniform shop the pickup of advance issue gear. Supervise the return of all unused gear.

4 Perform other duties as assigned.

(b) Reporting. The Indoctrination Supply Officer reports to the Regimental Supply Officer on all matters pertaining to their billet. The Indoctrination Supply Officer reports to the Indoctrination Sub-Commander regarding all other matters.

(24) Indoctrination First Lieutenant. The Indoctrination First Lieutenant is responsible for the cleanliness and material condition of Indoctrination Class spaces.

(a) Duties and Responsibilities. The Indoctrination First Lieutenant will:

1 Coordinate and supervise Indoctrination Class cleaning bills with the Regimental First Lieutenant to ensure the cleanliness and material condition of all assigned spaces.

2 Inspect all Indoctrination Class spaces daily, taking corrective action when necessary.

3 Make discrepancy reports to the Regimental First Lieutenant regarding discrepancies in the material condition of Indoctrination Class spaces.

4 Perform other duties as assigned.

(b) Reporting. The Indoctrination First Lieutenant reports to the Regimental First Lieutenant on matters pertaining to their billet. The Indoctrination First Lieutenant will report to the Indoctrination Sub-Commander on all other matters.

(25) Indoctrination Staff. The primary job of Indoctrination staff is to assist the Indoctrination Commander in the daily operation of the Indoctrination Class. This does not preclude Indoctrination Staff from assisting the Regimental Sub-Commander in the daily operation of the Regiment. Indoctrination Staff report to the Indoctrination Sub-Commander.

3 Jul 14

(26) H-Class Commander. The H-Class Commander has overall responsibility for the efficient organization, administration, and operation of H-Class. The DPOCS, Lead RDC, and CDI are the Class Team for H-Class and will guide and supervise the H-Class Commander in the execution of their duties.

(a) Duties and Responsibilities. The H-Class Commander will:

1 Delegate duties and authority to members of the H-Class Staff as necessary to carry out the routine of H-Class.

2 Ensure all H-Class formations, drills, meetings, and appointments are conducted punctually and in a military manner.

3 Maintain established standards of performance.

4 Report all disciplinary matters to the Class Team.

5 Disseminate all orders, directives, and policies from higher authority to H-Class using the proper chain of command, ensuring their prompt and efficient compliance.

6 Ensure muster reports are submitted as required.

7 Ensure a check-out log is maintained and all H-Class candidates are made aware of their responsibility to log in-and-out whenever they leave the Regiment.

8 Perform other duties as assigned.

(b) Reporting. The H-Class Commander reports to the Regimental Sub-Commander.

(27) H-Class Sub-Commander. The H-Class Sub-Commander functions as an executive to the H-Class Commander. The H-Class Sub-Commander is specifically charged with executing the orders of the H-Class Commander. Additionally, the H-Class Sub-Commander is responsible for coordinating and supervising the

3 Jul 14

performance and administration of H-Class to include matters pertaining to discipline, training, drill, watches, and morale (including rights and privileges).

(a) Duties and Responsibilities. The H-Class Sub-Commander will:

1 Supervise and coordinate all activities of the H-Class Staff.

2 Serve as Senior Watch Officer of H-Class.

3 Perform other duties as assigned.

(b) Reporting. The H-Class Sub-Commander reports to the H-Class Commander.

(28) H-Class Adjutant. The H-Class Adjutant functions as an executive assistant to the H-Class Sub-Commander for all military evolutions and required reports.

(a) Duties and Responsibilities. The H-Class Adjutant will:

1 Coordinate training evolutions within H-Class.

2 Issue and disseminate directives and policies to H-Class.

3 Formulate plans and schedules for H-Class.

4 Report administrative policies and procedures of H-Class.

5 Prepare and maintain permanent rosters of H-Class.

6 Perform other duties as assigned.

(b) Reporting. The H-Class Adjutant reports to the Regimental Adjutant regarding matters pertaining to their billet. The H-Class Adjutant will report to the H-Class Sub-Commander regarding all other matters.

3 Jul 14

(29) H-Class Supply Officer. The H-Class Supply Officer is responsible for the handling and distribution of materials used by H-Class.

(a) Duties and Responsibilities. The H-Class Supply Officer will:

1 Supervise and coordinate the distribution of materials used by H-Class.

2 Perform other duties as assigned.

(b) Reporting. The H-Class Supply Officer reports to the Regimental Supply Officer on all matters pertaining to their billet. The H-Class Supply Officer reports to the H-Class Sub-Commander regarding all other matters.

(30) H-Class First Lieutenant. The H-Class First Lieutenant is responsible for the cleanliness and material condition of H-Class spaces.

(a) Duties and Responsibilities. The H-Class First Lieutenant will:

1 Coordinate H-Class cleaning bills with the Regimental First Lieutenant to ensure the cleanliness and material condition of all assigned spaces as well as adjacent areas.

2 Inspect all assigned spaces daily and take corrective action when necessary.

3 Make discrepancy reports to the Regimental First Lieutenant regarding discrepancies in the material condition of assigned spaces and grounds.

4 Perform other duties as assigned.

(b) Reporting. The H-Class First Lieutenant reports to the Regimental First Lieutenant on matters pertaining to their billet. The H-Class First Lieutenant will report to the H-Class Sub-Commander on all other matters.

(31) H-Class Staff. The primary job of H-Class staff is to assist the H-Class Commander in the daily operation of H-

3 Jul 14

Class. This does not preclude H-Class Staff from assisting the Regimental Sub-Commander in the daily operation of the Regiment. H-Class staff report to the H-Class Sub-Commander.

(32) Regimental Environmental Body. The Primary job of the Regimental Environmental Body is to help assist OCS staff with informing students to properly dispense their trash to appropriate dumpsters by enforcing students to adhere to OTCN and Naval Station Newport's waste disposal policies. The Regimental Environmental Body reports to the Regimental Sub Commander.

SECTION 3 - WATCHES

231. Organization. The watchstanding reporting hierarchy is shown in Figure 2-3. Due to the nature of training at OCS, it is sometimes necessary for a senior class to be absent from the training area, requiring junior personnel to assume a senior watch station. In other cases the Executive Officer may order additional watches to be manned or stand down certain watches.

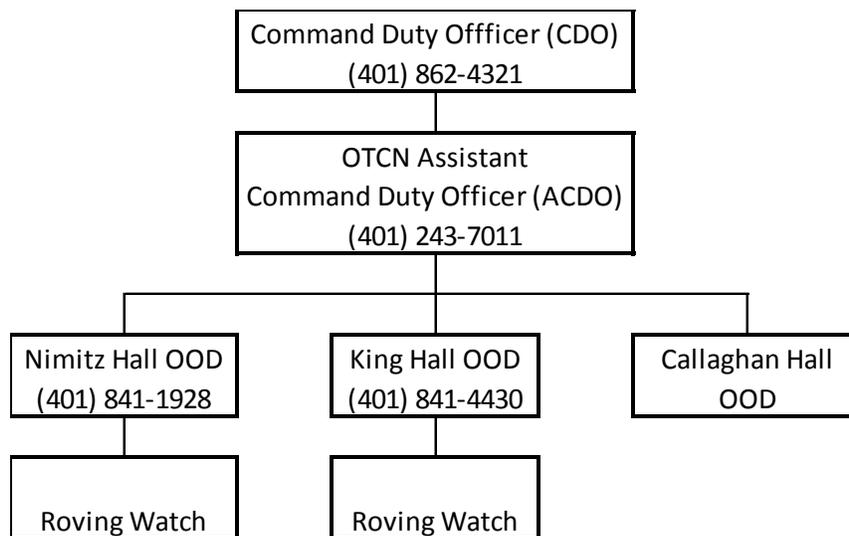

Figure 2-3

232. Watch Standing Duties

a. Indoctrination Phase. Candidates in Admin Week are not assigned watches. Upon successful completion of First

3 Jul 14

Friday, Indoctrination Candidates will begin qualifying as watchstanders.

b. Officer Candidate Phase. During the Officer Candidate Phase, Officer Candidates will stand the Nimitz Hall Rover Watch and Nimitz Hall OOD after completing two Under Instruction (U/I) watches for each. These watches will be assigned by the Senior Watch Officer.

c. Candidate Officer/Applied Leadership Phase. Candidate Officers will stand watches defined in OTCNINST 1601.1 with the exception of CDO.

d. H-Class. H-Class candidates who have completed Admin Week may stand watches as Nimitz Hall OOD or Rover once they have qualified. H-Class Candidates will not stand watches during physical training.

233. General Watchstanding Requirements

a. General. All watchstanders will conduct themselves in the spirit of the 11 General Orders of a sentry.

b. Watch Instructions. Watchstanding in OCS is governed by OTCNINST 1601.1. General watch descriptions are provided below and detailed watch instructions are provided at each watch station. **NOTE: OTCNINST 1601.1 "DUTIES AND RESPONSIBILITIES FOR OFFICER TRAINING COMMAND NEWPORT WATCH ORGANIZATION" takes precedence over any conflict with the OCR.** Each candidate will qualify for their assigned watch by standing a minimum of two watches under instruction (U/I) of a qualified watch stander and completion of the Student Watchstander PQS (Personnel Qualification Standard) as outlined by OTCNINST 1601.1G before standing King Hall OOD (Officer of the Deck) or Rover. Candidates shall read and understand all standing orders and instructions prior to assuming the duty.

c. Precedence. Watch takes precedence over all activities. Exceptions will be handled on a case by case basis and shall be approved by proper authority.

d. Meals. Watchstanders will manage their time to ensure no meals are missed. Relief by a qualified watchstander is authorized in order to meet this requirement.

e. Wristwatches. Watchstanders are authorized to wear a wristwatch while on duty.

3 Jul 14

f. Scheduling. The Regimental Watchbill Coordinator is responsible for developing and promulgating a watchbill. The watchbill shall man all required watches and be rotated daily through all classes. The watch rotation will be in 4-hour shifts. Candidates are assigned watches from the beginning of the second week of training until 0700 on the Wednesday before graduation. Any deviation from an approved watchbill requires the consent of the Student Watchbill Coordinator.

234. Candidate Watches Overview. Upon successful completion of First Friday, Indoctrination Candidates will begin qualifying as watchstanders. During the Officer Candidate Phase, Officer Candidates will start by standing the Nimitz Hall Rover Watch upon completion of two U/I watches.

a. Nimitz Hall OOD. The Nimitz Hall OOD watch is responsible for the safety, security, and good order and discipline of the regiment. The Nimitz Hall OOD will be stood by a qualified watchstander.

(1) Schedule. Nimitz Hall OOD will be manned Monday through Thursday 1800 to 0700, 1800 Friday through 0700 Monday, and during holiday routine when students are residing in the building. Normally Officer Candidates will be assigned to Nimitz Hall OOD. This does not preclude Candidate Officers of Lieutenant Commander and below from standing Nimitz Hall OOD. While an Indoctrination Class is onboard, the Indoctrination Staff will not normally be expected to support the Nimitz Hall OOD watch bill. **NOTE: WATCHES WILL BE EVENLY DIVIDED BETWEEN ALL CLASSES.**

(2) Uniform. The uniform for Nimitz Hall OOD is the Khaki Uniform with green watch belt.

(3) Duties and Responsibilities. All Nimitz Hall OOD watch standers will:

(a) Execute watchstanding duties in accordance with OTCNINST 1601.1G.

(b) Maintain a deck log, noting all significant occurrences during watch. Ensure PII and HIPAA sensitive information are not recorded.

(c) Oversee the Nimitz Hall Rover Watch in the execution of their duties.

3 Jul 14

(d) Ensure correct Quarterdeck procedures, military courtesy and bearing is observed and maintained by all military personnel during the watch.

(e) The Nimitz Hall OOD will ensure that all subordinate watchstanders maintain correct proper uniform appearance.

(f) The Nimitz Hall OOD will maintain the smart appearance of all assigned spaces at all times.

(g) Check the ID of all visitors and verify their need to be in the building prior to granting access to Nimitz Hall.

(h) Ensure all candidates are in the proper uniform and not loitering in assigned spaces.

(i) Inspect each watch stander prior to relief.

(j) Train and qualify all U/I Nimitz Hall OOD/Roving Watchstanders in their duties and responsibilities.

(k) Ensure the physical security and integrity of Nimitz Hall through a minimum of hourly rounds conducted by Nimitz Hall Rover Watches. Log the completion of these rounds in the quarterdeck log.

(l) Report failures of climate control systems, electrical systems, telephone systems, and alarm systems to the OTCN Assistant Command Duty Officer (ACDO).

(m) Notify the ACDO of any discrepancies found during roving rounds or report anything unusual.

(n) Maintain the candidate liberty log.

(o) Turnover personal gear adrift to the Regimental 1st LT or CDO.

(4) Study Materials. Academic study materials are the only authorized literature that may be read while on watch.

(5) Reporting. The Nimitz Hall OOD will report all items of interest to the OTCN Command Duty Officer. The oncoming Nimitz Hall OOD will report to their assigned watch station 15 minutes prior to assuming the watch for inspection by

3 Jul 14

the off going Nimitz Hall OOD and to receive a thorough briefing prior to turning over.

b. Nimitz Hall Rover Watch (Rover). The Rover is responsible for ensuring the proper security of Battalion spaces and to assist the Nimitz Hall OOD. Candidates must complete two U/I watches before qualifying as Rover. The Rover is responsible for knowing and complying with instructions pertaining to this watch.

(1) Schedule. Nimitz Hall Rover Watch will be manned Monday through Thursday 1800 to 0700, 1800 Friday through 0700 Monday, and during holiday routine when students are residing in the building. The watch rotation will be in 4-hour shifts.

(2) Uniform. The uniform for Rover is the NWU with green watch belt.

(3) Duties and Responsibilities. All Nimitz Hall Rover Watchstanders will:

(a) Report to the Nimitz Hall OOD to receive a thorough pass down, read the watch instructions, and receive a uniform inspection 15 minutes prior to assuming the watch.

(b) Conduct hourly security rounds to ensure good order and discipline, safety, and security are maintained within assigned spaces.

(c) Report all discrepancies and violations to the Nimitz Hall OOD.

(d) Ensure correct military courtesy and bearing are observed and maintained by all military personnel during the watch. The Rover will ensure the use of proper naval terminology in all conversations, correspondence, and announcements.

(e) Ensure that all lights in the Regiment are secured by taps (including all berthing spaces). Ensure all windows are shut.

(f) Ensure all candidates are in the proper uniform and not loitering in the passageways.

(g) Check bulletin boards to see that all orders, notices, POD and memoranda are up-to-date and arranged neatly. Remove outdated material.

(h) Turnover personal gear adrift to the Regimental 1st LT, ACDO, or Class Team.

3 Jul 14

(i) Report to the Nimitz Hall OOD 15 minutes prior to being properly relieved to conduct turnover with oncoming Rover.

(4) Reporting. The Rover will report to the Nimitz Hall OOD.

c. King Hall Rover Watch (Rover). The Rover is responsible for ensuring the proper security of spaces and to assist the King Hall OOD. Candidates must complete two U/I watches before qualifying as Rover. The Rover is responsible for knowing and complying with instructions pertaining to this watch.

(1) Schedule. King Hall Rover Watch will be manned Monday through Thursday 1800 to 0700, 1800 Friday through 0700 Monday, and during holiday routine when students are residing in the building. The watch rotation will be in 4-hour shifts.

(2) Uniform. The uniform for Rover is the NWU with green watch belt.

(3) Duties and Responsibilities. All King Hall Rover Watchstanders will:

(a) Report to the King Hall OOD to receive a thorough pass down, read the watch instructions, and receive a uniform inspection 15 minutes prior to assuming the watch.

(b) Conduct hourly security rounds to ensure good order and discipline, safety, and security are maintained within assigned spaces.

(c) Report all discrepancies and violations to the King Hall OOD.

(d) Ensure all windows are shut.

(e) Turnover personal gear adrift to the King Hall OOD.

(f) Report to the King Hall OOD 15 minutes prior to being properly relieved to conduct turnover with oncoming Rover.

(4) Reporting. The Rover will report to the King Hall OOD.

3 Jul 14

CHAPTER 3
RIGHTS, RESPONSIBILITIES, REGULATIONS
AND PROCEDURES

SECTION 1 - RIGHTS AND RESPONSIBILITIES

311. Rights. Candidates have rights to ensure their wellbeing during training.

a. Medical Treatment. Candidates have the right to attend sick call for routine medical and dental treatment and to obtain emergency medical treatment at any time. Candidates exercising this right are not required to explain the reason they are seeking treatment to anyone other than a medical provider. Candidates shall remain in a Light Duty (LD) or Sick in Quarters (SIQ) status, as determined by appropriate medical personnel, while in possession of a valid medical chit. Chits should be routed to the Class Officer, then the Safety Officer. Medical related documentation shall be handled in accordance with HIPAA and Privacy Act guidelines and only presented on a "need to know basis." Compliance with the Privacy Act of 1974 and the Health Insurance Portability and Accountability Act (HIPAA) of 1996 are not to be taken lightly and shall be adhered to at all times.

b. Sleep. Candidates shall have 7 hours of uninterrupted sleep between taps and reveille. Exceptions to this rule are scheduled watch, fire drills, quiet waking of individuals for documented administrative purposes (i.e. receipt of American Red Cross (AMCROSS) message, etc.), and command authorized searches.

c. Meals. Candidates shall be afforded three meals every day. Other than the meals provided from Ney Hall, no other food or beverage may be consumed other than water without the authorization of the Class Officer. Milk shall be available at every meal. The only food and beverage restrictions for Officer Candidates in effect at Ney Hall dining facility are those listed below. No other food or beverage restrictions of any kind are authorized. This includes direct or implied restrictions by OCS Staff or other Officer Candidates/Candidate Officers.

(1) Coffee/Tea/Soda is authorized only during the Candidate Officer phase or while in Medical Holding (MEDHOLD) class.

(2) Desserts, to be defined as the pies, cakes, cookies, brownies, and puddings in the rotisserie turnstile and ice cream, doughnuts, and pastries, are only authorized during

3 Jul 14

the Candidate Officer phase or while in MEDHOLD class. All other items such as jellies, honey, condiments, etc. are authorized.

(3) Indoctrination Candidates are only authorized "grab and go items", defined as the items in the serving line already made for the Indoctrination Candidates, during Admin Week (week 1) due to schedule time constraints, unless special arrangements are made for dietary needs.

(4) Holding Class Candidates will not be limited to "grab and go" meals.

d. Consultation

(1) Chaplain. Candidates may request and attend a chaplain's consultation at the earliest possible opportunity. For accountability purposes, all requests to see the chaplain should be arranged through the Class Team during normal operating hours or the OTCN CDO after normal operating hours.

(2) Class Officer. Candidates may consult with the Class Officer at any time.

(3) Legal. The Regional Naval Legal Service Office on base has military walk in service for legal assistance. Appointments can also be made. Candidates shall contact the Class Team prior to any consultation.

e. Religious Services. Candidates may attend and/or participate in Divine services per paragraph 336.

f. Grievances and Mast. Detailed grievance procedures are covered in paragraph 126. Grievances may be reported verbally or in writing to the Commanding Officer, via the chain of command. If the grievance is against the chain of command, a candidate may request mast via the Schools' Administrator and attend the same per prescribed procedures.

g. Administrative Matters. Candidates may tend to pending administrative matters, including personal affairs, when time permits.

h. Mail. Candidates will receive all packages and all mail including letters, literature, and newspapers addressed to them. Candidates may write letters during personal time. Privacy of written correspondence shall be maintained to include, but not limited to, incoming and outgoing mail. All packages received shall be opened by addressee in view of a

3 Jul 14

member of the Class Team in order to prevent the introduction of contraband into the training environment. Contraband should be placed in the candidate's lucky bag as appropriate. Personal correspondence shall be stowed in the personal gear drawer.

i. Visitors. Candidates may receive visitors as prescribed in paragraph 327.

312. Responsibilities

a. Financial. Candidates shall not be delinquent in their financial responsibilities. Difficulties in meeting debts must be brought to the attention of the Class Team. Failure to meet financial obligations may be investigated as a possible Officer Like Quality (OLQ) failure. The Director, Officer Candidate School (DOCS) shall forward college loan deferment requests, but shall not favorably endorse the correspondence until a Candidate meets all qualifications for graduation. Deferments shall be endorsed during the 12th week of training.

b. Personal Business. Candidates are responsible for conducting and completing all personal business to ensure it does not interfere with training. The Class Team shall assist with any special telephone or correspondence requirements for conducting personal business, but candidates must ensure all personal affairs are in order.

c. Regulation Compliance. Candidates are responsible for complying with all written and verbal instructions.

d. Computer Use. Computer usage is governed by current OTCN policy as outlined and reviewed during the command Automated Data Processing (ADP) brief.

(1) Monitoring. All government computer activity is monitored. The use of external memory devices (thumb drives, cameras, iPod, iPads, or any other hardware with a USB or serial port) is prohibited. Candidates shall not access commercial web email accounts or pornographic/inappropriate websites on the internet or download any type of data onto government computers. Examples of inappropriate sites include but are not limited to:

(a) Racist/Hate sites

(b) Dating Services

(c) Gambling

3 Jul 14

(2) Usage Hours. As candidates progress through training, they shall receive increased computer usage hours. The following hours are authorized:

(a) Indoctrination Candidates. Indoctrination Candidates are not allowed computer use.

(b) Officer Candidates. Officer Candidates are authorized academic use of computers Monday-Saturday during study periods. Personal use of computers is only authorized after the completion of the RLP inspection on Sundays and holidays from 0730 to 1800, or in an emergency situation with the approval of the Class Team. Personal use of computers is defined as using the computer for any matter not related to training at OCS.

(c) Candidate Officers. Candidate Officers are authorized computers IAW the Navy System Authorization Access Request Form from 1800-2200 Monday - Saturday. Candidate Officers are authorized personal use of computers on Sundays and holidays from 0730 to 2200 or while in liberty status. Personal use of computers is defined as using the computer for any matter not related to training at OCS.

(3) Blogging or the use of any social media site is not authorized while in a candidate status at Officer Candidate School.

SECTION 2 - REGULATIONS

321. Gifts. The only gifts which Candidates are authorized to give to Class Team/Staff members are:

- a. Class T-Shirt/PT outer-gear
- b. Class Coin
- c. First Salute \$1 Coins (ie. the Presidential Dollar Coin). Actual value of the coin must not exceed \$1.

Note: The giving of any of these gifts is completely voluntary.

322. Room Regulations

a. Living Space Set-up and Regulations. The Class Team shall provide additional guidance for rooms with non-standard

configurations. Furniture shall not be rearranged, added or removed without permission of the Class Team. Candidates' rooms shall be maintained in the following manner: (Refer to Figure 3-1.)

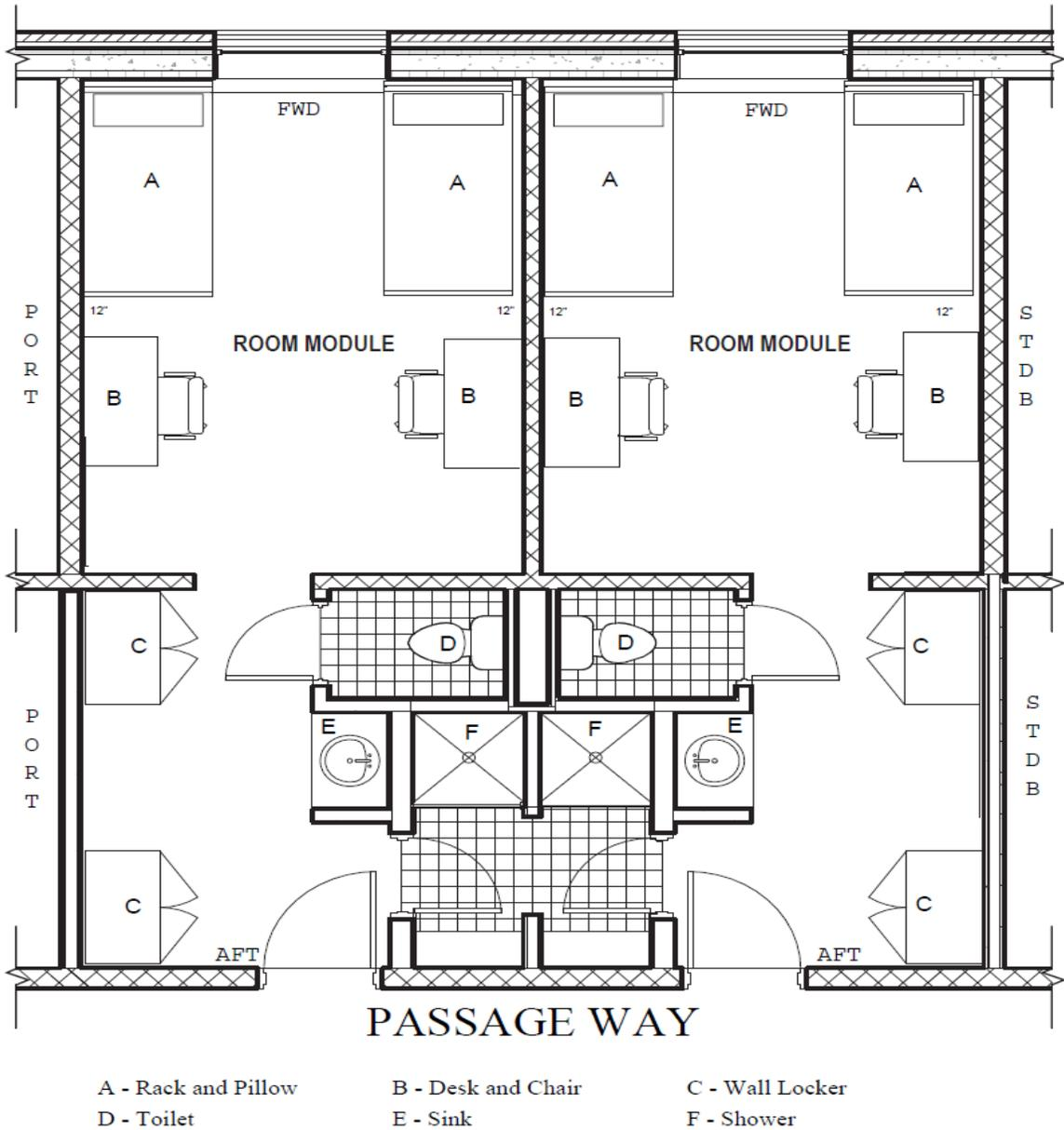

Figure 3-1

3 Jul 14

(1) Racks (refer to figure 3-2 for further guidance)

(a) Racks shall be grounded to the forward (FWD) bulkhead and to the port side (PORT) or starboard side (STBD) bulkhead as applicable.

(b) The mattress shall be grounded to the headboard and the inboard side of the rack.

(c) The enclosed bed locker shall be locked when utilized by the students. The bed shall be made with two clean sheets and one blanket. The lower sheet shall be tucked under the mattress in a "hospital corners" method (45 degree angle) at the head of the bed. The upper sheet and the blanket shall be tucked under the mattress with "hospital corners" (45 degree angle) at the foot of the bed. The upper sheet and blanket shall be folded back 12 inches from the front edge and center of the mattress. The fold shall be 6 inches wide. The only exception is during linen exchange/cleaning.

(d) A pillow in a clean pillowcase shall be centered at the head of the bed with excess material tucked into the pillowcase opening. The "admiral's smile" (opening) shall face outboard. **Candidates shall sleep between the sheets in their own rack every night.**



Figure 3-2

(2) Desks and Chairs. Desks shall be grounded to the PORT or STBD bulkhead as applicable and 12 inches apart from the foot of the rack. Chairs not in use, shall be grounded to the desk and centered.

(3) Wall Lockers. Wall lockers shall be grounded to the centerline bulkhead and AFT bulkhead on the bulkhead opposite of the sink. Wall lockers shall be shut and locked when rooms are unoccupied. Lockers are subject to inspection at any time.

(4) Windows. Windows shall be closed and locked unless required to be opened by a staff member. If open, all windows

3 Jul 14

in the passageway shall be opened to the same height. Curtains shall be closed when candidates are not fully clothed. Curtains shall be opened at all other times between reveille and sunset. Curtains shall be closed between sunset and reveille. Articles shall not be hung in windows or stowed on windowsills with the exception of wet running shoes to allow proper drying. This exception, when used, shall be uniform throughout the Regiment.

(5) Doors

(a) Doors of occupied rooms shall remain open from reveille to taps when the candidate is in the room and closed when the candidate is not in the room. Additionally doors will remain closed from taps to reveille and when personal hygiene matters are being conducted (i.e. shower use) or when students are changing uniforms.

(b) Head and shower doors shall remain open when not in use.

(c) Latches on the doors shall not be used at any time for any purpose, neither to lock nor prop door open.

b. Cleanliness

(1) Company Spaces. By 0800 Monday through Saturday, rooms shall be inspection ready and remain in that condition throughout the day. Furniture, windowsills, and curtains shall be dust free. Racks shall be made, gear shall be stowed, and decks shall be clean. When rooms are occupied, study items and inspection preparation items may be unstowed. When rooms are vacated, items shall be restowed to an inspection ready condition.

(2) Common Regimental Spaces. Such spaces (i.e. classrooms and laundry rooms) shall be maintained, cleaned, and stowed. Regimental and Battalion First Lieutenants shall assign a common space cleaning bill.

(3) Cleaning Gear Lockers. All cleaning equipment shall be properly stowed. Lockers shall be kept clean and properly stocked with cleaning supplies, paper towels and toilet paper. Swabs shall be rinsed out and stored in the racks provided outside.

c. Linen Exchange. On specified days sheets and pillowcases shall be removed from racks and collected by the

3 Jul 14

Linen Body. The Linen Body shall count and bundle sheets in sets of 25 by laying one sheet on the deck, placing 24 sheets in the center and tying the four corners in a square knot. Pillowcases shall be bundled by placing 24 into one. When less than 25 sheets and pillowcases are turned in, the Regimental Supply Officer shall combine them with the other classes. While awaiting clean linen, blankets shall be folded and centered on the rack. The single edge of the blanket shall face the bulkhead. The pillow shall be placed lengthwise on top of the blanket.

d. Unassigned Rooms. Wall lockers designated as common storage lockers or gear lockers shall be closed and locked when not in use. All other lockers shall be unlocked and open-racks in unassigned rooms shall be trice up. **Candidates shall not stow gear in a room not assigned to them, unless permitted by the DPOCS or DOCS.**

323. Prohibited Activities. Candidate involvement in any activity discrediting in nature or prejudicial to good order and discipline or safety is prohibited. Candidates are always expected to use good judgment. The following activities are specifically prohibited:

a. Fraternization. Fraternalization, as defined in paragraph 128, shall not be tolerated. While at OCS, candidates shall date neither officers nor enlisted members. Social media contact between Students and Staff is prohibited. The Combined Bachelors' Quarters is off limits and shall not be utilized. Socializing between candidates and staff is prohibited except at official OCS functions such as the staff and student challenge, graduation reception, and the graduation ceremony. Socializing between candidates within the Regiment and candidates in Student Pool or MEDHOLD is prohibited, except while at Religious Services.

b. Hazing. Hazing, as defined in paragraph 129, shall not be tolerated. Candidates suspected of hazing shall be referred to a Performance Review Board (PRB) for a Class "A" Offense.

c. Candidate Relationships. Dating and sexual contact between candidates is prohibited. Closed door meetings between any two candidates that are not already roommates are prohibited.

3 Jul 14

d. Decorum. Public displays of affection including holding hands are not appropriate.

e. Sleeping. Sleeping, resting, and sitting on racks is not permitted between reveille and taps. For Candidate Officers, sleeping or resting on racks is permitted during periods of mandatory rest and authorized liberty periods. Footwear and uniforms shall not be worn while sleeping or resting on the racks. Candidates that are Sick-in-Quarters (SIQ) may sleep or rest in their rack. Between taps and reveille, lights will be off and candidates shall sleep. **Candidates shall sleep only in their assigned rooms and assigned racks unless directed otherwise by the DPOCS, DOCS or CDO.**

f. Tobacco. The use of any type of tobacco product, or nicotine delivery device while in training at OCS is prohibited. This applies to both on and off-duty (liberty/leave) situations.

g. Gambling. Gambling in any form is prohibited.

h. Pets. Candidates are not allowed to have pets within Regimental spaces.

i. Tattoos/Body Art/Brands. The application of new tattoos is prohibited while assigned to OCS.

j. Mutilation. Intentional body mutilation, piercing, branding, intentional scarring are prohibited. Some examples are:

(1) A split or forked tongue.

(2) Foreign objects inserted under the skin to create a design or pattern.

(3) Enlarged or stretched out holes in the ears other than a normal piercing.

k. Motorcycle Riding/Driving. Motorcycle riding/driving while at OCS is prohibited.

l. Hitchhiking. Hitchhiking is prohibited.

m. Hazardous Activities. Participating in hazardous activities, such as scuba diving, sky diving, bungee-jumping, hunting or private piloting/flying is prohibited.

324. Personal Property

a. Privately Owned Vehicles (POV). POVs shall be parked in designated candidate parking areas. Only Candidate Officers are allowed to operate motor vehicles while training at OCS. Candidates may be allowed special access to POVs with permission from the Class Officer. When candidates are allowed special access to their vehicles, cell phone use is forbidden.

b. Civilian Clothing and Baggage. Candidates are not permitted to wear civilian clothing except during periods of leave. Each class shall be provided access to the gear locker (Lucky Bag Room) to stow their civilian clothing and baggage. All bags, containers, and gear shall be marked with the full name and class number of the owner. Gear lockers shall be locked; however OCS is not responsible for articles left behind or improperly secured.

c. Authorized Optional Items. The following sections list optional items approved for possession. Use restrictions for items are listed individually.

(1) Toiletries

(a) General. Razors, electric razors, shaving cream, toothbrush, toothpaste, dental floss, mouthwash, soap, shampoo, and astringent.

(b) Cosmetics (Women Only). Small amounts are authorized for use on liberty and during the Candidate Officer phase of training. See the uniform section for additional restrictions.

(c) Contact Lenses. Contact lenses are authorized for use during Candidate Officer phase.

(d) Colognes, Perfumes, and Scented Toiletries. Colognes, perfumes, and scented toiletries are authorized for use only during liberty and the Candidate Officer phase of training.

(2) Foot Powder. Topical foot powder and creams intended for the treatment or prevention of minor fungus infections (e.g. Desenex).

(3) Records. Records are defined as any military records, ID Cards or civilian documents required to conduct

3 Jul 14

personal business. Once military records have been used for their intended business they shall be returned to the respective candidates for proper storage and disposition.

(4) Flashlight. A small flashlight that uses a maximum of two "AA" batteries.

(5) Hair Dryer. Small hand-held or portable type.

(6) Small Containers. Plastic, self-sealing style containers only.

(7) Miscellaneous. Stamps, stationery, laundry supplies, clothes iron, money, checkbook, sun block, chap stick.

(8) General Cleaning. OTCN provides all cleaning supplies. Candidates are not authorized to possess any hazardous materials (i.e. lighter fluid, acetone, ammonia, corrosives, etc.). If a hazardous material is required, candidates shall request permission from their Class Team to possess those materials. If authorized for use, hazardous materials shall be issued and controlled by the OTCN staff.

(9) Cellular Phones. Only the Class President, VP, ADJ, and Med Body are authorized cell phones. Candidate Officers are authorized cell phones.

(10) Religious Scriptures. Any sacred scriptures that facilitate the worship of an Officer Candidate (i.e. Holy Bible, Torah, Koran, Book of Mormon, etc.) are authorized to be kept in the candidate's coffin locker.

325. Contraband and Health and Comfort Inspections

a. Contraband. Illegal items or substances in the possession of a candidate at any point during training shall be dealt with in accordance with military, state, and federal laws/regulations. "Contraband" is defined as any item that is prejudicial to the good order and discipline, health, welfare, or safety of any candidate at OCS. Indoctrination Candidates shall be afforded the opportunity to destroy, mail home, or store in a POV any legal contraband item(s) that is/are in their possession upon arrival at OCS. Any items found in the Regimental spaces to which Officer Candidates have access are considered to be in the Officer Candidate's possession. Where any doubt about an item exists, the Class Team should be consulted for further guidance. The following items are

3 Jul 14

specifically identified as illegal; however, this list should not be considered all-inclusive:

(1) Weapons. Any weapon (including edged, pointed and impact weapons) is contraband. Firearms, knives of any length, and letter openers are prohibited.

(2) Chemicals. Any cleaning supplies or chemicals other than those approved in paragraph 3202 are contraband.

(3) Food and Beverages. Beverages are defined as any drink other than water. Indoctrination and Officer Candidates may not possess or consume food or beverages except those provided by Ney Hall during scheduled meal hours unless authorized by the Class Team. Candidate Officers may obtain and consume additional food or beverage as directed by their Class Team. Candidates who are SIQ shall consume galley provided meals in their room.

(4) Alcohol. Any variety of alcohol related products are prohibited in Regimental spaces. This includes flavor extracts and candies but does not include mouthwash or authorized medication.

(5) Tobacco. No tobacco products or products intended to deliver nicotine (e.g. nicotine gum or patches) shall be possessed or consumed by candidates.

(6) Medicine. Any medicines (prescription or over-the-counter medications) that have not been approved by appropriate military medical authority are contraband. Indoctrination Candidates arriving with medicine that has been prescribed by civilian medical providers shall bring that medicine to Naval Health Care Clinic New England (NHCNE) and King Hall Medical staff for approval during the Indoctrination phase physical screening. Officer Candidates must consume prescription medication as directed; unconsumed medication may not be possessed beyond the calculated expenditure date (e.g., 9 total tablets to be taken one tablet 3 times daily should be completely consumed in 3 days), unless prescribed to be taken "AS NEEDED". Candidates may possess unconsumed "AS NEEDED" medication but cannot transfer that medication to another candidate. All medication must be in its original container with an appropriate prescription label.

(7) Vitamins. Daily Multivitamins are authorized for use as directed by the original container. The Daily

3 Jul 14

Multivitamin will be kept in its original container. Any other Mineral/Herbal supplements (i.e. Creatine, HMB, Nitrous Oxide, green tea extract, weight loss supplements) are not authorized.

(8) Electronic Equipment. Any electrical/electronic device not listed in paragraph 3204 is contraband.

(9) Gambling and Gaming Equipment. Any equipment associated with gambling or gaming (e.g. cards, dice etc.) is contraband.

(10) Lights. Any light that uses more than two "AA" batteries is not allowed.

(11) Containers. Possession containers intended for storing unauthorized chemicals, food, beverages, alcohol, tobacco or medicine is considered the equivalent to possession of the item itself and is considered contraband.

(12) Cameras. Personal cameras are not authorized at OCS. Photographs and video shall only be taken by the Regimental Public Affairs Officer at the discretion of the OTCN Staff Public Affairs Officer, XO or CO.

b. Health and Comfort Inspections. The CO (Commanding Officer) has the authority to conduct random health and comfort inspections. Health and Comfort inspections ensure Candidates live in sanitary conditions, that good order and discipline is maintained and living spaces are contraband free.

c. The Class Team, LRDC, and CDI have the authority to inspect all non-locked spaces of a candidate's room at any time. All rooms will be inspection ready at all times.

326. Leave and Liberty

a. Leave. Leave is governed by the LEAVE AND LIBERTY POLICY FOR CANDIDATES ASSIGNED TO OFFICER TRAINING COMMAND NEWPORT (OTCNINST 1050.2C). Candidate leave granted shall be granted on a case-by-case basis.

(1) Holiday Leave. OCS will normally have a standdown period in December. Candidates should not make travel plans until the travel policy has been promulgated and leave dates are published. Candidates not taking leave shall remain at OCS.

3 Jul 14

(2) Civilian Attire. Candidates may wear appropriate civilian clothes at their leave destination in accordance with Navy Uniform Regulations but shall be in uniform when checking out and off of leave.

b. Liberty. Liberty at OCS, as with all inspections and academic examinations, is a test. **As a member of the U.S. Armed Forces, you are an Ambassador of the United States and the Navy.** Candidates shall maintain their military bearing and exhibit the highest standards of conduct at all times while on liberty.

(1) Conduct Deficient Candidates. Conduct Deficient candidates are not authorized liberty regardless of the liberty status of their class.

(2) Navy Birthday Ball. The Navy Birthday Ball is an event that Candidate Officers may participate in at the discretion of the OTCN chain of command. In order to facilitate watch standing and training requirements, participation shall be as specified in a liberty memorandum.

(3) Liberty Requirements. The OTCN candidate liberty policy is outlined in OTCNINST 1050.2C. Additionally the following regulations shall be observed.

(a) Uniforms. Candidates shall wear the service khaki uniform while on liberty. PT gear is authorized during liberty only while actively engaged in PT on base.

(b) Liberty Check-out/in. Candidates must display the highest grooming and hygiene standards and an immaculate uniform while on liberty. All candidates must check-out when departing for, and check-in when returning from liberty in the appropriate liberty uniform.

(c) Responsible Use of Alcohol. Candidate Officers may consume alcohol on liberty in accordance with OTCNINST 5350.5 and OTCNINST 1050.2C. Excessive alcohol consumption and inappropriate behavior is not tolerated. Zero alcoholic drinks are allowed for those under 21 years of age; Zero alcoholic drinks before driving a motor vehicle; no more than 1 alcoholic drink per hour; and a maximum of 3 alcoholic drinks per evening is the Command Policy (0-0-1-3). One alcoholic drink is defined by 12oz of 5% alcohol/volume beer, 6oz of wine, or 1.5oz of liquor. Candidates with civilian guests are responsible for the actions of their guests, especially with regard to the consumption of alcohol. Alcohol

3 Jul 14

shall not be consumed within eight hours of assuming watch or the next training event.

(d) Seatbelts. In compliance with NAVREGS, seatbelts shall be worn while in vehicles.

(e) Officer's Club. Candidate Officers may patronize the Officer's Club with the appropriate liberty uniform.

327. Visitors. Candidates are allowed to receive visitors on the secondary Nimitz Hall quarterdeck only. Guests are only allowed on the quarterdeck. Visitors shall be listed on a base access form to be granted access to Naval Station Newport.

a. Indoctrination Phase. Candidates in the Indoctrination Phase of training are not authorized visitors. Indoctrination Candidates in H Class greater than three weeks may submit a special request chit to the DOCS via the Lead Class Officer (LCO) to have visitors. Visitation shall be on the secondary Nimitz Hall quarterdeck on Sundays from 0730 to 1100.

b. Officer Candidate Phase. Officer Candidates may have visitors on the Nimitz Hall Secondary Quarterdeck on Sundays from 0730 to 1100. Candidates must notify the Class via special request chit

c. Candidate Officer/Applied Leadership Phase. Candidate Officers are allowed visitors on liberty. To request a visitor as a liberty buddy, Candidates must submit special request chits to the DOCS via the Class Officer.

d. Restricted Candidates. Restricted Candidates are not authorized visitors. Candidates must submit a special request chit to the Class Officer for any deviation.

328. Physical Training (PT)

a. Medical Clearance. Candidates may not participate in PT until cleared by medical using the Physical Activity Risk Factor Questionnaire (PARFQ).

b. Physical Fitness Assessments (PFAs)

(1) The Navy PFA consists of two portions. The first portion is Body Composition Assessment (BCA). Candidates who fail to meet the BCA standard for their age group shall be

3 Jul 14

placed in H Class for three weeks to improve their physical fitness. At the end of three weeks, if a Candidate is not within BCA standards, the Candidate may be disenrolled from OCS by the Commanding Officer. If a Candidate arrives at OCS exceeding BCA standards by more than three percent body fat the Candidate may be disenrolled from OCS by the Commanding Officer.

(2) The second portion of the PFA is the Physical Readiness Test (PRT). There are four PRT's at OCS; the Initial Strength Test (IST), Initial Physical Fitness Assessment (In-PFA), Mid Physical Fitness Assessment (Mid-PFA) and the Out Physical Fitness Assessment (Out-PFA).

(3) IST. Determines if Indoctrination Candidates are physically prepared to commence the OCS PT Program.

(a) The IST is conducted early in Admin Week.

(b) Candidates must achieve an overall minimum score of "Satisfactory" on the IST. Candidates who are unable to pass the Initial Strength Test upon arrival at OCS will be placed in H Class for three weeks to improve their physical fitness. If, at the end of three weeks, a Candidate is unable to take and pass a second PFA attempt, the OC may be disenrolled from OCS by the Commanding Officer.

(c) Candidates who previously wore orange reflective belts shall change to green reflective belts upon scoring at least a "Satisfactory" on any PRT and joining another class.

(4) Initial Physical Fitness Assessment (In-PFA). The In-PFA assesses individual candidate and class progression in the OCS Physical Training Program following the IST.

(a) The In-PFA is normally conducted on Friday of week four.

(b) The passing grade for the In-PFA is an overall score of "Satisfactory". All candidates who fail to score a minimum of "Satisfactory" shall be placed in H Class until they have scored a minimum of satisfactory on the PRT and are directed by OCS staff to class up with the next OCS class.

(5) Mid Physical Fitness Assessment (Mid-PFA). The Mid-PFA assesses individual candidates and class progression in

the OCS Physical Training Program following the IST since the In-PFA.

(a) The Mid-PFA is normally conducted on Friday of week eight.

(b) The passing grade for the Mid-PFA is an overall "Good".

(c) Any candidate who fails to achieve an overall score of "Good" on the Mid-PFA may be rolled back to the next OCS Class. The final decision shall be made by the DOCS.

(6) Out Physical Fitness Assessment (Out-PFA). The Out-PFA assesses how individual candidates and the class improved physical readiness in the OCS Physical Training Program. The Out-PFA is an official Navy PFA. The results of the Out-PFA shall be entered into the candidates' Physical Readiness Information Management System accounts.

(a) The Out-PFA is normally conducted on Friday of week eleven.

(b) The passing grade for the Out-PFA is a "SAT" in all categories. Candidates who fail to score a minimum of a "SAT" in all categories shall have a PRB (Performance Review Board) to determine the required PT remediation.

c. Swim Requirements. Candidates must successfully complete the Navy Third Class Swim Qualification prior to commissioning.

(1) The Third Class Swim Qualification is normally conducted on Monday or Tuesday in week two.

(2) Candidates failing the Third Class Swim Qualification shall attend remedial swim beginning on Tuesday of week six until they qualify.

(3) If a candidate has not passed the Third Class Swim Qualification by Tuesday of week nine, the candidate's record will be routed to the LCO, DPOCS, DOCS for potential rollback or referral to a PRB.

(4) If a Candidate has not passed the 3rd Class Swim Qualification prior to the CAPSTONE Event, then the Candidate will not participate in the Combat Pool Portion.

3 Jul 14

d. Poor Performance. Candidates continually performing well below the majority of a class in any physical training area (e.g. falling out of runs, push-ups, etc.) shall receive written counseling by the Class Team and remedial instruction while continuing training with the class. At the discretion of the Class Officer, the candidate's record will be routed to the LCO, DPOCS, DOCS for potential rollback or referral to a PRB.

329. Officer-like Qualities (OLQ). The development and display of these qualities determines a Candidate's suitability to move forward into the next phase of training and ability to commission as an Ensign in the United States Navy.

a. The Officer-like Qualities for which all Candidates will be evaluated are those most critically important for their initial success as Junior Officers:

- (1) Honesty/Integrity
- (2) Work Ethic
- (3) Initiative
- (4) Military Bearing/Character
- (5) Dependability
- (6) Teamwork
- (7) Leadership

b. Officer-like Qualities are evaluated from Day 1 through Graduation. Unsatisfactory performance is grounds for roll-back in training or recommendation for attrition.

c. Candidates will receive an OLQ FITREP while at OCS. The Class Officer is the Reporting Senior for all OLQ FITREPS. Appendix H displays an OLQ FITREP.

(1) The Officer Candidate Phase OLQ Mid-term Counseling will be given at the end of week 6.

(2) The Candidate Officer Phase OLQ FITREP will be given during week 11. Candidate Officers will provide OLQ FITREP inputs to their Class Officer no later than the end of week 10.

3 Jul 14

(3) Additional OLQ FITREPS may be given in special circumstances such as PRB's, H-Class, etc.

c. The OLQ FITREP is based on a 1.0 to 5.0 scale.

d. A member trait average of 3.0 is meeting (minimum) standards.

e. If a Candidate receives a trait average below 3.0, or any individual trait 2.0 or below the candidate may be forwarded to the DOCS for potential roll-back.

3210. Medical Regulations

a. General. Candidates shall not train unless medically qualified and cleared to participate.

b. Candidate Responsibility. **Candidates are responsible for reporting changes in their medical status to the Class Team.**

(1) Candidates shall notify the chain of command of any incident relating to their medical status and/or when any medical personnel, including civilian facilities, treat them. Candidates are not required to report their specific medical conditions to anyone other than medical personnel; however they must notify the Class Team of LD (Light Duty) or SIQ (Sick in Quarters) status.

(2) Candidates authorized by medical personnel to wear braces or support devices must have chits authorizing their use.

c. Duty Modification Chits/Medical (Med Chit)

(1) When a candidate receives a Med Chit, they shall provide a copy to the Class Officer. If the Chit is a result of an injury, the Candidate will immediately meet with the Lead Class Officer, DPOCS, and the OTCN Safety Officer.

(2) The second copy shall be placed in the candidate's port breast pocket folded neatly behind their ID card.

(3) SIQ Med Chits require an additional copy to be turned in to the Section Leader and used to pick up the candidate's meals from the chow hall.

3 Jul 14

d. Self-Medication. Candidates shall not purchase or consume over-the-counter medications. All medication must be prescribed or approved by appropriate military medical authority, and documentation must be made in the candidate's health record.

e. Light Duty (LD)/Sick In Quarters (SIQ)

(1) Any candidate placed on SIQ/LD status that limits physical activity from check-in Sunday up through the completion of Fast Cruise shall be rolled to H Class.

(2) Candidates placed in a "No Duty" or SIQ status for two consecutive training days may be rolled to H-Class. If assigned to H-Class, the candidate shall not be assigned to another class until returned to full duty ("med up"). The determination to roll a candidate the candidate shall be made by the DOCS.

(3) Candidates placed in a LD status for five or more training days may be rolled to H-Class. The determination to roll a candidate shall be made by the DOCS.

(4) Candidates repeatedly placed on SIQ or LD status may be rolled to H-Class until they are capable of commencing training. The determination to roll a candidate shall be made by the DOCS.

f. Heat Stress

(1) General Information. Candidates should be aware of the symptoms that accompany potentially life-threatening heat conditions. These conditions result when the body's normal cooling mechanism breaks down. Heat stress takes three forms: heat cramps, heat exhaustion and heat stroke. Table 3-3 lists symptoms and treatment.

3 Jul 14

<u>Condition</u>	<u>Symptoms</u>	<u>Treatment</u>
Heat Cramps	<ul style="list-style-type: none"> - Severe muscle cramps (especially in legs, calves and abdomen) - Faintness, dizziness 	<ul style="list-style-type: none"> - Stop exercising - Move the individual to a cool environment - Lay the individual on his/her back and fan - Direct cold water or apply cold compresses to the groin areas and armpits - Notify the CDO and Branch Medical clinic - For afterhours heat cramps, notify the Naval Hospital
Heat Exhaustion (Serious)	<ul style="list-style-type: none"> - Pale or flushed, clammy skin - Dilated pupils - Faintness, dizziness - Weakness and exhaustion - Unconsciousness (with other symptoms) 	<ul style="list-style-type: none"> - Same as heat cramps EXCEPT in case of collapse where one should: - Call an ambulance immediately (911 or 841-3333) - Make sure the victim's airway is open - Lay the individual on his/her side to facilitate safe vomiting
Heat Stroke (Most serious)	<ul style="list-style-type: none"> - Flushed, hot, dry skin - Constricted pupils - Faintness, dizziness - Change in consciousness - Rapid, weak pulse - Rapid, shallow breathing 	<ul style="list-style-type: none"> - Same treatment as heat exhaustion EXCEPT with greater urgency: - Body temperature must be lowered as soon as possible by whatever means available - Untreated heat stroke invariably leads to death

Table 3-3

3 Jul 14

(2) Heat Stress Prevention

(a) Fluids. Drink enough water to pass clear urine (a sign of full hydration). Drinking sufficient water is the best way to avoid heat stress. Canteens are required to be full at all times.

(b) Diet. Eat foods rich in potassium such as bananas, baked potatoes (including the skin), leafy vegetables, and whole grains to maintain the correct electrolyte balance.

g. Hypertension (High Blood Pressure). If left untreated can lead to serious health problems. Hypertension is typically a symptomless condition. Risk factors may include: family history, age, lack of physical exercise, diet, obesity, smoking, gender and race. Diagnosis should be made by a healthcare professional.

h. Cardiac Arrest. The abrupt loss of heart function, caused when the heart's electrical system malfunctions. Without warning, it occurs instantly or shortly after symptoms appear. Table 3-4 lists warning signs of cardiac arrest.

<u>Sign</u>	<u>Assessment</u>	<u>Action</u>
<u>Sudden loss of responsiveness</u>	<u>No response to tapping on the shoulders.</u> <u>Does nothing when you ask if they're OK.</u>	<u>Yell for help.</u> <u>Direct someone to call emergency response (401) 841-3333 or 911 and get the AED.</u>
<u>Check for breathing</u>	<u>Person isn't breathing or is only gasping.</u>	<u>Initiate CPR.</u> <u>Push hard and fast in the center of the person's chest.</u> <u>Continue until the arrival of the AED (Turn the machine on and follow voice prompts) or until someone with more advanced training takes over.</u>

Table 3-4

3211. Miscellaneous Regulations

a. Verbal Response. Indoctrination Candidates and Officer Candidates shall respond in a loud, firm, confident voice (ballistic) at all times with Class Drill Instructors, Class Chief Petty Officers and Candidate Officers with the following exceptions: Candidates shall not be ballistic in/or around the Command Suite, NEX, and Callaghan Hall. Candidates shall not be ballistic with Class Officers at any time. Candidate Officers are not required to speak ballistically.

b. Remedial Physical Training (RPT). When a candidate spot corrected by use of RPT by a staff member other than the Class Team, the candidate will immediately report the infraction to a member of the class team following completion of RPT.

c. Training Building Conduct

(1) Passageways. Passageways are for transiting. Loitering is not permitted. Talking in passageways is prohibited unless when addressing a staff member or Candidate Officer.

(2) Food and Beverages. No eating or drinking (except water) is allowed outside of Ney Hall Galley unless approved by the Class Officer.

d. Recycling. As part of NAVSTA NEWPORT, OTCN is required to recycle to the maximum extent possible. Candidates will separate their recyclables and place them in the proper container outside Nimitz Hall.

SECTION 3 - PROCEDURES

331. Courtesies

a. Saluting

(1) Proper Salute. As illustrated in Figure 3-4, raise the upper right arm to a position parallel to the deck. Place the forearm at a 45-degree angle with the hand and wrist straight. Face palm slightly inward, thumb and fingers extended and joined, with the tip of the forefinger touching the bill of the headgear just over the starboard eye as if shielding the sun. You should be able to see the entire palm when looking straight ahead. Face the individual being saluted and hold the salute until the officer has returned and acknowledged your

3 Jul 14

salute. After the senior officer acknowledges your salute, bring the arm down smartly to your side. If the right arm is incapacitated (i.e. in a cast and/or sling) a salute shall be rendered in the same manner with the left hand.



Figure 3-4

(2) Who to Salute. Salute all officers, high-ranking dignitaries of the United States government and of all recognized nations. Salute all commissioned officers in civilian clothes that are recognized. Candidates shall not salute Candidate Officers. Salute all official vehicles with standards not cased or with a flag officer insignia on the front plate. Candidates may, while on base in the course of their travel, receive a salute from junior enlisted personnel. If this occurs, return the salute and give the appropriate greeting. This shall assist in reinforcing their military bearing and discipline.

(3) When to Salute. The salute is rendered when covered and from a position of attention. The salute is rendered when the person or National Ensign is at a minimum six paces distance or at the closest point of approach, a maximum of 30 paces.

(a) Return of a salute is mandatory.

(b) When escorting or accompanying a senior, for purposes of saluting and rendering military courtesies, the junior assumes the rank of the senior and salutes with the senior.

(c) If walking, continue walking and salute from an erect position. If running, come to a walk, render a salute then carry on after the salute is returned.

3 Jul 14

(d) If engaged in conversation with an officer outdoors or on watch, the conversation shall commence and terminate with a salute.

(e) During morning and evening colors, stop, face colors or the direction of the music and render a salute from the first note of the National Anthem or Retreat and drop the salute at the last note and remain at attention until "carry on" is played. If in formation all personnel shall come to a halt, the formation leader shall face the flag or music and salute for the formation.

(4) Saluting While on Duty and Under Arms. Candidates standing watch on the Quarterdeck shall salute all officers. Officers not in uniform shall be saluted if they are recognized. Candidates shall be instructed by their Drill Instructor on the proper method to salute while carrying a rifle.

(5) When not to Salute. The following are occasions when salutes are not rendered. When saluting is not appropriate, the greeting of the day shall still be rendered.

(a) Uncovered. When in uniform and uncovered.

(b) In Formation. Only the leader of the formation salutes for the formation.

(c) Work Details. When working as a member of a work detail.

(d) Carrying Articles. When both hands are required to carry articles.

(e) PT Gear. While engaged in athletics or wearing PT gear, including the wearing of a watch cap.

(f) Inappropriate Occasions. In public conveyances, where obviously inappropriate, or where confusion shall result (i.e., saluting at long distances, or in control of a moving vehicle).

b. Bracing. Is performed at the position of attention with the candidate's back and heels four inches from the bulkhead

3 Jul 14

(1) Inside of Nimitz Hall, whenever staff members enter or leave the deck, candidates shall brace the bulkhead and give the greeting of the day.

(2) "Attention on Deck" is to be used for all Officers and "Attention on Deck, Standby" for all Drill Instructors and Chief Petty Officers.

(3) If a single candidate is on deck, the candidate shall brace the bulkhead and give the greeting of the day. If multiple candidates are on the same deck, the candidate who first recognizes the staff member shall call out "Attention on Deck" or "Attention on Deck, Standby" and all the candidates shall brace the bulkhead and give the greeting of the day.

(4) When the staff member enters the deck, candidates shall remain braced until given further instruction. When the staff member exits the deck, candidates shall carry on.

(5) If multiple staff members are transiting together, courtesies shall be rendered for the senior individual.

(6) If a staff member is already on deck, candidates shall not brace the bulkhead or give the greeting of the day except for the XO (Executive Officer) and CO (Commanding Officer).

(7) Candidate Officers shall not brace the bulkhead nor call attention on deck except for the Commanding Officer and Executive Officer.

(8) Candidates conducting sweepers shall give the greeting of the day but shall not brace.

c. Greeting of the Day

(1) The greeting of the day is "Good Morning (0001-1200)/ Afternoon (1201-1800)/ Evening (1801-2400), Sir/Ma'am/Chief/Senior Chief/Master Chief/Staff Sergeant/Gunnery Sergeant/Master Gunnery Sergeant," as appropriate and is given simultaneously with a salute if covered when encountering an officer.

(2) If a wristwatch is not worn, Candidates shall use meals as a guide for the greeting of the day: Morning is used before lunch, Afternoon is used after lunch and before dinner, and Evening is used after dinner.

3 Jul 14

(3) All Candidates shall address Senior Enlisted Personnel by their appropriate title (i.e. Good Morning Chief/Senior Chief/Master Chief/ Staff Sergeant/ Gunnery Sergeant/Master Gunnery Sergeant, etc.).

d. Overtaking a Senior. When overtaking an officer, (while walking) request "By your leave, Sir/ma'am" followed by the greeting of the day. When given permission to pass, with the response, "Granted" or "Carry on," salute and pass on the port side of the individual, unless that side is obstructed.

332. Formations. Formations are used to move personnel in a military manner from point "A" to point "B".

a. Platoon Formation

(1) Applicability. A platoon formation shall generally be used for candidates traversing from one evolution to another. Candidates shall form in columns based on the number of personnel with a unit leader positioned to the port side of the formation.

(2) Courtesies. The unit leader shall render courtesies for the formation.

b. Independent Steaming

(1) Applicability. Candidates not in a platoon formation are considered to be independent steaming. Candidates shall steam in a single file on the starboard side of the sidewalk or road and move at a 120 pace per minute gate (unless in a light duty status).

(2) Courtesies. When independent steaming with more than two candidates, only the first and last candidates (normally the Section Leader) shall render appropriate courtesies.

333. Building Procedures

a. Passageways. Candidates shall traverse passageways on the starboard side with their right shoulder four inches from the bulkhead. All corners shall be squared. Candidates shall not cut the deck unless instructed by a staff member.

3 Jul 14

b. Office Entry and Exit. Offices are not uniform; therefore, facing movements must be adjusted to coincide with the floor plan. All swinging doors are to be pulled open and shall not be allowed to swing freely after entry/exit.

(1) Knocking

(a) Candidates shall approach the door from starboard with the right shoulder four inches from the bulkhead and halt so that the shoulder is even with the doorframe. The candidate shall ground their canteen to the bulkhead and then check their appearance prior to stepping off.

(b) Stepping off with the left foot, the candidate shall move to the center of the doorway, halt, execute a right face and adjust to the center of the doorway if needed.

(c) With the palm of the right hand, the candidate shall knock three times at eye level on the doorframe in a loud, vigorous manner and await acknowledgement. If they are told to enter, proceed to the next section. If the candidate is instructed to state his or her business, the candidate shall give the greeting of the day, state, "Sir/Ma'am/Chief/Senior Chief/Staff Sergeant/Gunnery Sergeant, Officer Candidate _____, Class XX-XX," and state his or her business. If told to wait, the candidate shall conduct a right face and shall proceed to a position just starboard of the doorway and shall wait in accordance with the guidelines given below.

(2) Proceeding to the Desk

(a) When proceeding to the desk of an enlisted staff member without an officer present, move in the most direct route to a position 12 to 18 inches in front of, and centered on, the desk.

(b) If proceeding to the desk of an enlisted staff member and an officer is present, or to a staff officer's desk and a senior officer is present, take one-step into the office and halt when directed to enter. Face the officer or senior officer. If covered, salute the officer and hold while giving the greeting of the day; if uncovered, simply give the greeting of the day. Await acknowledgment. Move in the most direct route to a position 12 to 18 inches in front of and centered on the desk of the person who authorized the entry.

(3) At the Desk

(a) Report: "Sir/Ma'am/Chief/Senior Chief/Master Chief/Staff Sergeant/Gunnery Sergeant, Officer Candidate _____, Class XX-XX, reporting to _____ as ordered" or, when requesting to speak: "Sir/Ma'am/Chief/Senior Chief/Master Chief/Staff Sergeant/Gunnery Sergeant, Officer Candidate _____, Class XX-XX, requests permission to speak to _____." If covered and interviewing with an officer, a salute is rendered with the report.

(b) If given the order "stand at ease," the candidate shall do so but shall not sit down unless specifically told to "sit down," "have a seat," etc. When seated, the candidate shall sit "at ease."

(4) Dismissal

(a) When dismissed or instructed to "carry on," if at any position other than attention, the candidate shall come to attention.

(b) Take one-step to the rear with their left foot swinging their left arm six inches forward and the right arm 3 inches to the rear of the right leg. Bring the right heel against the left, assuming the position of attention.

(c) Answer "Aye-Aye, sir/ma'am/Chief/Senior Chief/Master Chief/Staff Sergeant/Gunnery Sergeant." If covered and interviewing with an officer, the report is rendered with a salute.

(5) Exiting

(a) If interviewing with an enlisted staff member and an officer is present or if interviewing with an officer and a senior officer is present, face the officer or senior officer. If covered, salute the officer and hold while giving the greeting of the day; if uncovered, simply give the greeting of the day. Await acknowledgment.

(b) Execute the appropriate facing movement (left, right or about face) to face the door in the most direct manner.

(c) Cross the door threshold with the left foot first. While pivoting the head 90 degrees to the starboard render the appropriate greeting of the day, while crossing the

3 Jul 14

threshold. Once outside, execute a left face and proceed to recover their canteen.

(d) If exiting to wait for a group of candidates, proceed around the deck returning to the end of the candidates awaiting interviews.

c. Awaiting Office Entry

(1) When waiting to enter an office, candidates shall position themselves on the starboard side of the doorway, at parade rest, with their back to the bulkhead and heels four inches from the bulkhead.

(2) Situational awareness of the deck is required to ensure appropriate honors are rendered. When a staff member steps onto the same deck as the candidate, the candidate shall brace and give the greeting of the day (if covered, the candidate shall salute and give the greeting of the day to all commissioned officers). If several candidates are waiting and a staff member steps onto the same deck, all shall give the greeting of the day simultaneously.

(3) Once a candidate's name has been called, the candidate shall perform the office entry procedure.

(4) If several candidates are waiting and one candidate enters the office, the next candidate in line shall give the necessary facing movements to move the line down to wait next to the doorframe.

d. Opposite Sex Room Entry. Opposite sex room entry procedures are applicable only to berthing. Unassigned or unoccupied berthing areas and all other spaces are designated common spaces and considered areas possessing no reasonable expectation of privacy.

(1) Knock on the door or doorframe as per office entry procedures.

(2) State loudly "male on deck" if a male is attempting to enter a female berthing and "female on deck" if a female is attempting to enter a male berthing.

(3) Wait three seconds for a reply. If a reply is not received, repeat the above step one more time.

3 Jul 14

(4) If a reply is not received a second time, the berthing or head can be presumed empty and the candidate can enter.

(5) If any candidate in a berthing space is not in compliance with the minimum clothing provisions required by the OCR, a reply of "Wait" shall be made. Otherwise, a candidate in the space shall respond by announcing "Enter."

(6) Upon receiving the reply "Enter," open the door, enter the berthing, conduct business, and leave.

(7) The berthing door shall remain fully open any time candidates of the opposite sex are in the space.

334. Chow Hall Procedures

a. Entering

(1) After marching up the sidewalk in front of Ney Hall, the class shall execute the appropriate column movement and halt before the steps leading to the seaward side entrance.

(2) The Section Leader shall relieve the drill body and then proceed by marching to a position in front of the outboard squad, execute a column left and march up to the second set of steps. When the Section Leader's left foot strikes the deck of the top step the section leader shall turn their head to the right and give the greeting of the day. The Section Leader then performs a left face, centers themselves on the second squad leader, and faces left again. At this time the Section Leader shall ground their toes to the edge of the top step by executing a series of short choppy steps while looking down.

(a) The Section Leader shall then give the order, "Guide, post the guidon." The guide responds, "Aye-Aye, Section Leader." Following their response, the guide shall proceed with grounding the guidon.

(b) The Section Leader shall command "Class XX-XX, upon receiving the command of execution 'Move' you shall ground your (canteens/gear) to the (port/starboard) side." The class shall respond, "Aye-Aye, Section Leader" and pass their canteens/gear to the squad closest to the side they have been directed to ground their canteens/gear.

3 Jul 14

(c) After the guide returns to their position in the rear of the formation, the Section Leader shall then command "Class XX-XX, upon receiving the command of execution 'March' you shall half step up the ladder well and reform at the door." The class shall respond, "Aye-Aye, Section Leader."

(d) The Section Leader shall then command, "Half Step, March." The class shall then execute the movement while the Section Leader marches backwards with the class calling cadence.

(e) The Section Leader shall halt the class at the end of the sidewalk giving the command "Platoon, Halt."

(f) The Section Leader shall then command, "Ready, Adjust," at which time all candidates shall adjust any uniform items to ensure everyone is presenting a neat and clean appearance. Then they will reform at the door exactly one forearm's distance apart. Reflective belts shall be removed at this time and placed in the port cargo pocket. While doing so the class shall respond with:

"Discipline, D...I...S...C...I...P...L...I...N...E, Discipline is the instant, willing obedience to orders, respect for authority and self-reliance. Freeze, candidate freeze."

(g) The Section leader shall then command, "Standby to sanitize." The class shall respond, "Standby to sanitize, Aye-Aye, Section Leader." The Section Leader shall command, "MOVE." The entire class shall respond "KILL". On this command every squad leader with the exception of fourth squad leader shall snap their head to the right. The class shall proceed to the hand sanitizer, filing off one squad at a time until reformed in platoon formation and waiting for the next command.

(h) The Section Leader shall then command, "Door bodies off the rear."

(i) The class shall respond, "Door bodies off the rear, Aye-Aye, Section Leader." Followed immediately by "Aye-Aye, Section Leader" from the two door bodies.

(j) The two door bodies shall execute the appropriate facing movements to exit the formation, proceed to the door, with the second door body centered on the section leader. The second door body shall respond "door bodies

3 Jul 14

reporting as ordered Section Leader." The Section Leader shall respond, "Door Bodies, Post." Both door bodies respond "Aye-Aye, Section Leader." Both Door Bodies shall execute a right face, take one-step forward, face right, and take one-step backwards so they are positioned abreast of the Section Leader.

(k) The Section Leader shall then order, "Door bodies, report status of chow hall deck." The door bodies shall respond, "Aye-Aye, Section Leader." The second door body shall take one-step forward, face left and proceed to the second door. The first door body shall open the first door for the second door body.

(l) The second door body shall look through the door inside the chow hall to see if any classes are standing in line. If there are less than eight candidates in line, the door body shall perform an about face and step through the first set of doors until they are outside.

(m) Once outside the second door body shall respond, "Chow hall deck all clear, Section Leader." The entire class shall repeat this last statement. If there is a class standing in the chow line, the door body shall respond, "Chow hall deck not clear, Section Leader." The entire class shall repeat this statement. The Section Leader shall command, "Report status of chow hall deck when chow hall decks all clear." The door body shall respond, "Aye-Aye, Section Leader," and monitor the status of the line in the chow hall until it is clear, at which time the candidate shall follow the procedure for announcing the chow hall deck all clear.

(n) The Section Leader shall then order, "Door body, crack the door". The door body shall respond, "Aye-Aye, Section Leader," march to the second door, execute a right face and crack the door while back stepping.

(o) The Section Leader shall step forward with the left foot, execute a left face, march towards the chow hall door, step on the doorframe, lean into the chow hall, and state, "Class XX-XX, marching in for chow." The Section Leader shall then take their original position, by executing two right faces, march to his original position, execute a left face, and take one back step. The class shall respond, "Class XX-XX, marching in for chow."

(p) The Section Leader shall command, "Column of files from the right". The appropriate squad leader shall then

3 Jul 14

order, "Forward," and the other squad leaders then turn their heads to the right and order, "Stand fast," and the Section Leader shall then give the order, "March". The designated squad shall then step forward, remove their covers and sound off by number in sequence as the left foot strikes the door frame, until all members of the class have entered. The first and last candidate shall give the greeting of the day instead of their number.

(q) The section leader shall relieve the first door body by slapping his/her hand on the metal part of the door and giving the command "Proceed door body." The door body shall respond with "Aye-Aye, Section Leader" and proceed into the galley using the procedures listed above. The Section Leader shall then repeat this procedure for the second door body and then follow him/her into the galley.

b. Inside the Chow Hall

(1) Once inside the chow hall, the class shall continue single file until formed in a column of twos; stopping once parallel with the back edge of the sixth table from the door on the port side. **Ballistics in the chow hall are only authorized when Class Teams are present to supervise.**

(2) The Section Leader shall remain at the end of the line waiting for the class to form. The Section Leader shall center him/herself at the first stanchion and order "proceed class XX-XX". The class shall respond with "Aye-Aye, Section Leader".

(3) The front candidate in the port line shall command "Forward, March" (over right shoulder). The entire class shall take a step at the same time with their left foot saying, "Step, Freeze". The front candidate shall then command, "Stand fast". Front candidate in the port line shall stand fast, while the starboard side candidate takes six steps forward, and left flanks. Port line shall step off on starboard's fourth step, takes two steps and flank together with the starboard Candidate.

(4) When a candidate arrives at the stack of trays, he/she shall retrieve a tray and silverware as instructed by the Class Team. The candidate shall then execute two side steps or appropriate facing movements in order to form a line at the serving area. Candidates shall hold their trays with a posture of elbows tucked into sides, wrists and forearms straight and parallel to the deck. Candidates shall proceed through the

3 Jul 14

serving line by sidestepping along the food serving area and continue sidestepping around to the drink dispenser. Candidates shall then stop to get the designated beverages, and then execute a facing movement in order to form a line at the water station. Once water is placed on tray, candidates shall then march to appropriate tables for seating.

(5) Upon arriving at the table at which they are to sit, candidates shall place their trays on the table, arrange their glasses and silverware, stage jackets if necessary and then stand behind their chairs. Candidates shall then take out their study notepads and study their knowledge by extending their starboard arm straight out in front of their faces.

(6) Candidates shall arrange their trays as follows:

(a) The tray shall be placed one fist width from the outboard edge and grounded to the near edge of the table.

(b) Glasses shall be placed on the table grounded to the forward edge of the tray, with the water on the starboard side.

(c) Plates shall be centered and grounded to the bottom edge of the tray.

(d) Salad bowls shall be grounded on the port side. Fruit bowls shall be grounded on the starboard side.

(e) Bread, butter and condiments shall be centered and grounded to the upper edge of the tray.

(f) Silverware shall be grounded to the bottom of the tray and set with the fork to port of the plate, the knife to starboard of the plate (cutting edge inboard) and the spoon starboard of the knife.

(g) Once a candidate has arranged their tray, they shall return to the position of attention.

c. At the Table. All candidates shall wait to be seated by the Section Leader. The following commands shall be given:

(1) Section Leader: "Put it away, Class XX-XX." The class responds "Aye-Aye, Section Leader." Candidates shall put away their study materials then return to the position of attention.

3 Jul 14

(2) Section Leader: "Class XX-XX, these tables, both sides, ready, seats." Candidates shall pull out their chairs, enter from the starboard side and take a seat.

(3) Section Leader: "Adjust." (Candidates slide towards the table grabbing the bottom of the chair with the port hand. Candidates' stomachs shall touch the table. Candidates shall sit on the front one third of the chair).

(4) Section Leader: "Pray at will." Candidates shall snap their heads down and then simultaneously respond with "snap". (Candidates are given at least 10 seconds to bless their meal, if they wish).

(5) "Ready, eat." Candidates snap their heads to the front and then simultaneously respond with "snap".

(6) The Section Leader then commands, "Class XX-XX, this is your 20 minute warning". The class replies, "Aye-Aye, Section Leader." (Commence meal) The section leader gives 15, 10, and 5-minute warnings at the appropriate times.

(7) Candidates shall not talk during the meal.

(8) Candidates shall follow these exact procedures until they have completed the Capstone Event and entered Candidate Officer Phase.

d. Greetings. The greeting of the day shall not be given in the chow hall except upon entering and exiting.

e. Exiting

(1) When there is one-minute remaining, the Section Leader shall command, "Put it away Class XX-XX." At that time, all candidates shall respond, "Aye-Aye, Section Leader," and finish all of their fluids.

(2) When the allotted time has expired, the Section Leader shall command, "Class XX-XX, this is your immediate warning." Candidates shall fold up their napkins one inch by one inch and place them under their plates.

(3) The Section Leader then commands, "Class XX-XX, prepare to ground glasses on tray." The class shall respond, "Aye-Aye, Section Leader," and place their starboard hands

3 Jul 14

against the edges of the tables, fingertips touching the edge. When the Section Leader calls, "Ready," the entire class shall grab glasses with their starboard hands. On the command, "Move," the entire class shall place glasses on trays.

(4) The Section Leader shall then command, "Class XX-XX, prepare to take your feet." The class shall respond, "Aye-Aye, Section Leader." The Section Leader shall then command, "Ready," at which point the class shall grab the backs of their chairs with their starboard hands. Upon the command, "Move," the entire class shall stand and exit to the port side of their chairs, ground chairs to the table, and come to the position of attention (If candidates have jackets the Section Leader shall then command "Class XX-XX, prepare to don foul weather jacket/NWU Parka" The class shall respond, "Aye-Aye, Section Leader." The Section Leader shall then command, "Ready, move" the class puts on their jackets and reflective belts and return to the position of attention.

(5) The Section Leader shall then command, "Class XX-XX, prepare to face the scullery." The class shall respond, "Aye-Aye, Section Leader." The Section Leader then commands "Ready, move." The class shall execute the appropriate facing movement to face toward the scullery.

(6) The Section Leader shall then command, "Class XX-XX, prepare to recover trays." The class shall respond, "Aye-Aye, Section Leader," and upon the command, "Ready, move," the class shall pick up trays and assume a posture of elbows tucked into sides, wrists and forearms straight and parallel to the deck.

(7) The Section Leader shall command, "Column of files from the right (or left)." The appropriate squad leader shall order "Forward," after which the other squad leader shall order, "Stand fast." The Section Leader shall then order, "March." The class shall then file out, depositing trays at the scullery. The first two candidates to the scullery shall deposit all trays for the class. The third and fourth candidates shall hold the doors open for the rest of the class as they exit. The first and last candidates out of the mess shall render the greeting of the day. As the Candidates cross the threshold of the inner door, they shall don their head gear and gloves if necessary.

(8) Once outside, the class shall retrieve canteens/gear by side stepping along the line of canteens/gear and form up into a class formation at the position of attention

3 Jul 14

and the Section Leader/Drill Body shall march them to the next scheduled event.

335. Telephones/Correspondence

a. Telephones

(1) Official Telephone Calls. Candidates may make official telephone calls during any phase of training once approval is granted from the Class Officer.

(2) Personal Phone Calls. Authorized Quarterdeck phones shall be used for personal phone calls once proper authorization has been given from the Class Officer.

(a) Indoctrination Candidates. Indoctrination Candidates shall make a 5-minute phone call, to their next of kin notifying them they arrived safely. Additional phone calls, except in emergencies, are not authorized during Admin Week.

(b) Officer Candidates. Officer Candidates can make and receive personal calls Friday-Saturday from 2000 to 2200, and Sundays and Holidays from 0730 to 1600. Authorized cell phones (President/VP/ADJ/Med Body) are for official calls only. Personal calls will be made from the Quarterdeck phones.

(c) Incoming Phone Calls. Other than the specified times, candidates shall not be permitted to take incoming calls unless an emergency exists.

b. Personal Mail. Candidates may send and receive personal mail. Note that the Zip Code +4 is important to ensure timely routing. The mailing address is:

OC _____(name)_____
 OCS CLASS NO _____
 OFFICER TRAINING COMMAND
 1356 MEYERKORD AVE
 NEWPORT, RI 02841-1644

c. Official Military Correspondence. Official military correspondence shall be forwarded through the chain of command. Assistance in preparing official correspondence can be obtained from the Class Team and administrative staff.

3 Jul 14

336. Religious Services

a. Policy. DON policy is to accommodate the doctrinal or traditional observances of the religious faith practiced by individual members when these doctrines or observances shall not have an adverse impact on military, unit or individual readiness, unit cohesion, health, safety, discipline, or mission accomplishment. Accommodation of a member's religious practices cannot be guaranteed at all times and is subject to military necessity. Determination of necessity rests with the Commanding Officer.

b. Attendance. The attendance of religious services is strictly voluntary. Candidates may participate in services, religious education, choir, and serve as ushers on Sunday at the Chapel of Hope. Additionally, Candidates after the first week of training may attend Wednesday evening bible study at OTCN as mission accomplishment permits. The following procedures shall be followed during the Indoctrination and Officer Candidate phase for services at the Chapel of Hope:

(1) Candidates shall form up 20 minutes prior to the start of the worship service of their choice in front of the Nimitz Hall quarterdeck and be marched over, by a Candidate Officer to the south end of the Kay Hall parking lot. They shall be dismissed and immediately enter the Chapel of Hope through the double doors. Upon the completion of the service they shall immediately depart the sanctuary and form back up at the south end of the Kay Hall parking lot and be marched back to Nimitz Hall by a Candidate Officer. Those attending the bible study prior to or after services shall be marched to and from Perry Hall from the Kay Hall parking lot.

(2) Candidates are only authorized to attend the service. Sleeping, eating, or watching television in any area while attending religious services is not authorized.

(3) Candidates wishing to attend services not offered aboard Naval Station Newport, or who wish to attend services at a time other than on Sunday morning may do so after obtaining approval from the Class Officer, after consultation with the Command Chaplain, via a Special Request Chit. These candidates may request duty driver support to and from the services. Candidates who have been authorized to attend off-base religious services shall wear the following: NWU during weeks one through eight of training and Service Khakis after week nine of training

(Navy PTU is authorized if a Candidate has not yet purchased the NWU).

337. Medical and Dental Procedures

a. Medical Appointments. Candidates shall inform the Section Leader or chain of command before departing for any appointment. Officer Candidates shall only be transported in a government vehicle. Candidates shall arrive 30 minutes prior to their appointment time on the King Hall Quarterdeck. After their appointment, candidates shall return to training and inform the Section Leader or chain of command of their return. A copy of LLD/SIQ chits shall be turned in to the Class Team when they return to Nimitz Hall. All other documents pertaining to a candidate's health or those containing HIPPA sensitive information shall be delivered as directed by medical staff by the candidate receiving treatment. Unless otherwise directed, all documents shall be delivered to the OTCN Student Medical Liaison.

b. Sick Call. Candidate Sick Call is held at King Hall Branch Medical 0630-0900 Monday through Friday. Candidates who require medical attention on weekends or after working hours, shall inform the OTCN Command Duty Officer and their Class Team. Candidates requiring Sick Call on Physical Training days shall muster for PT with their class, detail to morning chow, and report to King Hall Branch Medical by 0630.

c. Medical Emergencies. Emergency medical treatment is provided by Naval Health Clinic New England (Ambulance phone number on base 401-841-3333 or dial 911 and tell them you are at Naval Station Newport). After hours, emergencies will be reported using the same number and transported to Newport Hospital. The Regimental Commander shall ensure that the Class Team and OTCN CDO have been notified when after-hours emergencies occur.

d. Non-emergency issues. All non-emergency medical problems, which occur after sick call but within the normal workday (0700-1545), must be seen at King Hall. Medical candidates shall report to a Candidate Officer or the Class Team when medical attention is required to ensure proper attention is received.

e. After-Hours Non-emergency issues. The CDO shall be contacted for all after-hours non-emergent issues. The CDO will contact the on-call medical provider (1-888-Navy-Med).

3 Jul 14

f. Medical Treatment Follow-ups. All candidates that receive medical treatment from any outside medical facility/health care provider shall report to the next scheduled sick call to be re-evaluated by King Hall Medical.

g. Dental Procedures. Dental sick call is Monday through Friday 0700-1600. Requests for dental care shall be coordinated via the Regimental Medical Liaison and the Class Team.

338. Fire or Emergency Evacuation Procedures

a. Per Navy Occupational Safety and Health (NAVOSH) requirements, Candidates are responsible for memorizing and following the fire evacuation diagrams posted in all passageways and rooms. All alarms shall be treated as an actual occurrence whether or not a drill is announced.

b. Evacuation Procedures. Upon the sounding of the fire alarm, all candidates shall quickly and orderly depart the building, proceed to designated muster areas, form up, and report muster results to the CDO. During inclement/cold weather candidates shall proceed to a non-affected OTCN building chosen by pertinent authority after the muster has been reported.

Designated muster areas are as follows:

Primary - Nimitz Field

Alternate - Kay Hall

3 Jul 14

CHAPTER 4
CONDUCT AND PERFORMANCE SYSTEM

SECTION 1 - GENERAL

411. Standards of Conduct. All candidates are expected to exhibit dedication, commitment to excellence, and exemplary standards of conduct and performance at all times, whether on or off-duty. This conduct applies to personal behavior and relations with others, whether civilian or military. The standards of conduct contained in this regulation are guided by Navy Regulations, the Uniform Code of Military Justice, the Code of Conduct, the Bedrock Standards of Conduct, and other regulations and instructions promulgated by higher authority. Candidates shall comply with the substance, spirit, and intent of these standards and avoid conduct that reflects discredit upon themselves, OCS, and/or the United States Navy. Additionally, candidates shall not violate local, state, or federal laws or conduct themselves in a manner that questions their personal morals. Candidates found delinquent in conduct or performance may be recommended for separation if it is determined their retention is not in the best interest of the Navy. It is impossible to cover every situation, therefore, in the absence of specific guidance, candidates are to be guided by initiative, common sense, and good judgment.

SECTION 2 - BASIC PRINCIPLES OF THE CONDUCT SYSTEM

421. Honor Code Violations

a. The Honor Code (paragraph 121) is a key tenet of the standards of conduct expected of all candidates. It is an integral part of life at OCS. Honor Code violations are especially egregious and are considered Class A offenses (see paragraph 432). An Honor Code violation could result in disenrollment from OCS.

b. Reporting Honor Code Violations. Candidates witnessing an Honor Code violation shall report it to their Class Team. A failure to do so is also a violation of the Honor Code. False or malicious reports will be treated as Honor Code violations.

422. Attempts to Commit an Offense. An attempt is the intention to commit an offense and may be processed as if the offense were committed.

3 Jul 14

423. Knowledge, Intent, and Severity. Violations of regulations, instructions, orders, or codes of conduct shall be evaluated on a case by case basis to ensure a just resolution occurs. When determining disposition of violations, the following factors may be considered:

a. Knowledge. The amount of time in training and reasonable expectation of knowledge of a regulation shall be considered. Ignorance of a regulation is never an excuse for violating it.

b. Intent. The level to which the violation was intended is directly related to the manner in which the offense will be punished.

c. Severity. The severity of the offense shall be evaluated in reference to other violations of the same offense and in relation to other conduct violations.

424. Witnessing a Delinquency. Witnessing, or having prior knowledge of, and failing to report to appropriate authorities the planning of any offense by another, is treated the same as if the individual who failed to report the offense, committed the offense.

SECTION 3 - THE CONDUCT SYSTEM

431. Reporting Offenses. OCS Report Chits (see Appendix G) shall be filled out by the individual placing a candidate on report. Chits shall reference the page and section of the OCR infraction when applicable. Report chits generated by staff members outside of the candidate's Class Team shall be submitted to the alleged offender's Class Team immediately. The Class Officer shall review, investigate, and process the chit as appropriate.

432. Candidate Offenses. Conduct violations are categorized, processed, and adjudicated as Class A, B, or C offenses.

a. Class A Offense. Class A offenses are especially egregious and directly call into question a candidate's leadership and ability to serve in the Navy.

(1) Examples of Class A offenses are listed below. This list is not all-inclusive.

(a) An Honor Code violation.

3 Jul 14

(b) Possession of firearms, ammunition, knives, or weapons of any kind while at OCS.

(c) Disregard or contempt for authority or disrespect toward superiors.

(d) Unauthorized absence (UA)/returning late from liberty or leave (greater than 30 minutes).

(e) Any action of misconduct that brings discredit upon the Navy such as public intoxication, hazing, fraternization, or gambling.

(f) A lack of or failure to develop OLQ's.

(g) Conducting Reinforcement Physical Training (RPT) or unauthorized touching of another candidate.

(h) Receiving a below standards OLQ grade from the Class Officer.

(i) The commission of two or more Class B offenses while at OCS.

(2) Corrective Measures. Candidates committing Class A offenses shall have their record forwarded to the DOCS. DOCS will determine the corrective measure up to and including rolling back one class. DOCS may determine the need for a Candidate to go before a Performance Review Board (PRB). The PRB will review and make recommendations concerning the offense.

b. Class B Offense. Class B offenses are less serious than Class A offenses, but generally indicate a willful disregard of or negligence in carrying out procedures, directions, or instructions.

(1) Examples of Class B offenses are listed below. This list is not all-inclusive.

(a) Late return from liberty or leave (less than 30 minutes).

(b) Tolerance of a regulation infraction by others (although in certain instances, such as Honor Code violations, tolerance of or failure to report an infraction may be considered a Class A offense).

- (c) Entering unauthorized areas.
- (d) Loss of/damage to government property.

(2) Corrective Measures. Class B offenses may result in:

- (a) EMI.
- (b) Demerits.
- (c) Record forwarded to DOCS for review.
- (d) Recommendation for a PRB.

c. Class C Offense. A Class C offense is a relatively minor deviation from expected standards. It may indicate that a candidate does not completely understand or is having difficulty attaining and maintaining standards. It may also signal that a candidate's performance is not progressing satisfactorily.

(1) Examples of Class C offenses are listed below. This list is not all-inclusive.

- (a) Improper performance of duty.
- (b) Improper submission of official paperwork.
- (c) Failure to retain required information.
- (d) Unsatisfactory personal appearance.
- (e) Failure to render military courtesies.
- (f) Minor violations of standing orders.
- (g) Failure to respond to a correction.
- (h) Failure to comply with instructions.
- (i) Failure to exercise good judgment.
- (j) Loss of military bearing.
- (k) Failure to place recyclables in the proper container outside Nimitz Hall.

3 Jul 14

(2) Corrective Measures. Punishment for Class C offenses can be demerits or RPT. When spot corrected by use of RPT by a staff member other than their Class Team, the candidate will report the infraction to a member of their class team immediately following completion of RPT.

d. Misuse of a Government Computer. Misuse of a Government Computer may be classified as a Class A, B, or C Offense dependent upon the nature of the misuse. The Class of the offense will be decided by the class team on a case by case basis. In the event that the offense is discovered and reported by NMCI (Navy and Marine Corp Internet) or other outside agency, the misuse will be considered a Class A offense.

SECTION 4 - CORRECTIVE MEASURES.

441. Demerits. Demerits may be assigned as follows.

a. Class A Offenses. A maximum of 25 demerits for Class A offenses.

b. Class B Offenses. A maximum of 10 demerits for Class B offenses.

c. Class C Offenses. A maximum of 2 demerits for Class C offenses.

442. Recording Demerits. Demerits shall be recorded by the awarding authority on the Demerit Documentation Form (see Appendix G). This form will be signed by the candidate and a copy will be provided to the Regimental Conduct Body (RCB).

a. The RCB is responsible for ensuring all candidates with outstanding demerits are accounted for as conduct deficient. The RCB will maintain a Demerit List of all assigned demerits within the regiment.

b. The Class Team will counsel the candidate and record it in the candidate's training folder. The Class Conduct Body will submit the completed Demerit Documentation Forms to the Class Officer.

443. Serving Demerits. Assigned demerits are worked off (as determined by the awarding authority) by RPT, marching tours, or a combination of RPT and marching tours. Candidates are expected to work off demerits expeditiously. Candidates shall

3 Jul 14

not be placed in a conduct deficient status or be eligible to work off demerits until after the successful completion of General Quarters.

a. One ten minute RPT session works off one demerit. Candidates must seek out a qualified staff member to administer RPT sessions. The candidate's demerit documentation form shall be signed off as soon as RPT is completed. All regulations regarding RPT shall be observed.

b. A marching tour is a 50-minute period where Candidates march, around the outer walls, in a square between east and center wing of Nimitz Hall at 120 steps per minute with a rifle at right or left shoulder arms. Candidates will come to order arms, execute a facing movement and return to right or left shoulder arms at each corner of the square. Location of tours may be changed based on weather conditions or space limitations. One marching tour works off one demerit. Tours will be monitored by a Candidate Officer for proper execution.

(1) A candidate is not credited for improperly executed marching tours and may receive additional demerits.

(2) No other activities are allowed in the vicinity where marching tours are being conducted.

(3) Marching Tours are conducted Thursday at 1800 and 1900; Friday at 1800, 1900 and 2000; and Saturday at 1400, 1500, 1600, 1800, 1900 and 2000.

(4) Candidates may be allowed to march accelerated tours in the Candidate Officer phase to meet graduation requirements or maintain their rank. The schedule for accelerated tours must be approved by the DOCS. A maximum of six tours per day will be authorized unless approved by the CO.

(5) Tours will be conducted in the Navy Working Uniform (NWU) and signed-off by any staff member, Candidate Officer holding the rank of Candidate Lieutenant Commander or above or the Regimental Conduct Body (RCB).

(6) Candidates may not perform marching tours if they are LD (Light Duty)(as documented on a medical chit), have an academic average below 70%, or within 48 hours of an academic test, unless authorized by the Class Officer. If this restriction precludes a candidate from working off all of their

3 Jul 14

demerits prior to graduation, disposition shall be directed to the OCS LCO.

444. Conduct Deficient Candidates. Candidates with outstanding demerits are in a conduct deficient status and shall be placed on the demerit list. Candidates will have one strip of yellow tape on the outboard edge of their nametag indicating that they are in a Conduct Deficient status. Candidates who are conduct deficient:

- a. Must work off all demerits prior to commissioning.
- b. Are restricted to Training Country until all demerits have been worked off, as certified by the RCB (Regimental Conduct Body).
- c. Are not authorized liberty unless authorized by Class Officer.
- d. Will not hold a Candidate Officer rank above Candidate Ensign.
- e. Demerit List (DL). The DL is a weekly compilation of demerits assigned to candidates in each class.

(1) The DL shows the candidate's name, class number, source of demerits received during the week and the status of outstanding demerits.

(2) The DL shall be published each Monday for review.

(3) The RCB is responsible for publishing the weekly DL. The RCB shall provide the weekly report to the DPOCS and LCO for review.

f. Muster. Candidates in a conduct deficient status are required to muster in the Service Khaki Uniform or NWU (Navy Working Uniform) prior to the Capstone Event or while executing tours at the Nimitz Hall OOD (Officer of the Deck) station 10 minutes before the top of each hour as follows:

Friday: 2000.

Saturday: 2000.

Sunday: 0800, 1200, 1600 and 2000 (except while attending religious services).

3 Jul 14

(1) Muster and inspection will be conducted at the OCS OOD station by a staff member, a Candidate Lieutenant Commander or above, or the RCB. Conduct deficient candidates who fail to muster before the top of the hour in the specified uniform will be reported as UA (Unauthorized Absence), and the RCB shall forward an OCS report chit documenting the offense.

(2) Candidates in a conduct deficient status shall sign out to attend religious services and sign in to report their return.

(3) Candidates may sign out to conduct academic studies in Callaghan Hall, but are still required to muster every hour at the Nimitz Hall Secondary Quarterdeck.

g. Removal from Conduct Deficient Status

(1) Candidates are removed from the conduct deficient list after working off all of their demerits and their Demerit Documentation Form has been turned in to the RCB.

(2) The RCB is responsible for collecting all completed Demerit Documentation Forms and updating the DL as candidates work off demerits.

445. Extra Military Instruction (EMI)

a. General. EMI is an instructive, administrative measure used to correct a deficiency. EMI is not punitive in nature and is not to be used as a substitute for non-judicial punishment. EMI must be logically related to the deficiency being corrected.

b. Guidelines for Administering EMI

(1) EMI will typically not exceed two hours per day and no more than five hours of EMI per week are authorized.

(2) EMI may be assigned at a reasonable time outside of normal working hours (usually 1800-2100 Monday thru Friday); however, conducting EMI shall not interfere with a candidate's sleep.

(3) EMI shall not be conducted longer than necessary to correct the deficiency.

3 Jul 14

(4) EMI shall not be assigned on a member's Sabbath.

(5) EMI shall not be used as a method to deprive normal liberty. A candidate who is otherwise entitled to liberty may commence liberty after completing each day's EMI.

(6) Class Officers, LCO, DPOCS, and the DOCS are the only OCS staff members authorized to assign EMI to Candidates. Class Officers may assign EMI only to those candidates in their respective class.

(7) The Class Officer is responsible for the proper administration of EMI. EMI assigned must be documented in the respective candidate's training records.

446. Performance Review Board (PRB) Procedures. PRBs are governed by OTCNINST 1620.2. Candidates directed to appear before a PRB will report to the designated place on time, and in a clean, squared away uniform. Candidates will maintain proper military bearing throughout the board.

a. Policy

(1) Review boards will be convened when counseling and remediation have failed to improve student performance. Certain conduct offenses may be referred directly to a Performance Review Board as described in Section 432. The following explains each type of review board and the criteria for each:

(a) Academic Review Board (ARB): An ARB is convened by the DOCS following a single academic retest failure. The ARB will be chaired by the OCS Lead Instructor or the Unit Manager for the particular course that was failed. Two other OCS Instructors, qualified in the academic unit being evaluated, will constitute the board. Depending on the student's demonstrated level of proficiency, the ARB will recommend to the OCS CS that the student either: 1) remain in the current class or, 2) be set-back to the next junior class.

(b) Performance Review Board (PRB): A PRB is convened by the Commanding Officer (CO), OTCN when a student fails to make adequate academic, military, physical fitness progress as explained below or when a conduct or honor violation calls into question a Candidate's suitability to train.

(1) Failure to maintain satisfactory academic progress. A PRB may be convened when a student's academic course

3 Jul 14

average falls below the minimum passing grade or the student has been subject to two ARBs.

(2) Failure to maintain military training progress. A PRB may be convened when a Candidate is unable to achieve the objectives of a military training test to include Room Locker Personnel Inspection, Officer Personnel Inspection, etc. after counseling, remediation, and retesting.

(3) Conduct or Honor Offense. A PRB may be convened for Class A offenses as delineated in Section 432. Class A offenses include serious offenses (e.g. drunkenness, assault) and honor violations (e.g. lying, cheating, etc.). A PRB may also be convened for a pattern of repeated lesser offenses.

(4) Failure to develop Officer Like Qualities. A PRB may be convened when a candidate fails to develop the key qualities required for a Naval Officer.

(c) The PRB may recommend that any of the following actions be taken.

- (1) No action;
- (2) Warning;
- (3) Extra Military Instruction;
- (4) Set-back one or more classes
- (5) Holding Company Remediation
- (6) Sea-wall
- (7) Disenrollment from OCS.

SECTION 5 - PERFORMANCE FAILURES

451. General. This section outlines general procedures for candidates who fail training evolutions. A candidate's Class Team closely monitors individual candidate progress. A candidate experiencing difficulties in any training area is encouraged to seek assistance from qualified staff members. Performance failures include:

- a. Academic Failures.

- b. Military Failures.
- c. Physical Fitness Assessment Failures.
- d. Swim Failures.

452. Officer-like Qualities Failure

a. Officer-like Qualities are evaluated from Day 1 through Graduation. Unsatisfactory performance is grounds for roll-back in training or recommendation for attrition.

b. If a Candidate receives a trait average below 3.0, the candidate may be reviewed by the DOCS for potential roll-back in training.

c. If a Candidate receives a trait average below 2.5 or a 1.0 in any one trait, the candidate will be reviewed by the DOCS for probable roll-back in training.

453. Academic Failures

a. Initial Failure. The minimum passing score is 70% on academic modules. Candidates who fail to score a 70% or higher will be assigned Extra Instruction (EI) by a qualified academic instructor. The final Academic Module average includes the quiz and the final exam. The Class Officer shall counsel candidates who fail an academic module. Candidates are normally remediated and retested within two working days.

b. Failure on Retest. Candidates failing to achieve a 70% shall attend an ARB to determine if that Candidate should repeat the academic module with the next junior OCS class.

454. Military Failure. Any candidate who fails a graded MTT (Military Training Test) will be debriefed and counseled by the Class Team. The candidate will be given remedial instruction and will normally be retested within two working days. Two consecutive failures of the same MTT will result in the candidate rolling to the next junior OCS class. The following evolutions are rollable MTTs:

a. Fast Cruise. Candidates who fail to complete Fast Cruise will be placed in Holding (H) Class until directed to join the next available OCS class.

3 Jul 14

b. RLP (Room, Locker, Personnel Inspection). Candidates who fail the initial RLP inspection will have the opportunity for re-inspection. Candidates who fail to achieve a minimum passing score of 80% on the RLP re-inspection will be rolled to the next junior OCS class.

c. Sixth Week PI (Personnel Inspection). Candidates who fail the initial Sixth Week PI inspection will have the opportunity for re-inspection. Candidates who fail to achieve a minimum passing score of 80% on the Sixth Week PI re-inspection will be rolled to the next junior OCS class.

d. OPI (Officer Personnel Inspection). Candidates who fail the initial OPI inspection will have the opportunity for re-inspection. Candidates who fail to achieve a minimum passing score of 80% on the OPI re-inspection will be rolled to the next junior OCS class.

455. PFA Failure. Refer to paragraph 328 for policies on PFA failures. Refer to Table 4-1 for PFA standards.

456. Swim Failure. Candidates who fail the 3rd class swim qualification will attend remedial swim beginning in week six. Candidates will receive training every Tuesday & Thursday until they pass. If a candidate is unable to pass the third class swim qualification by Tuesday of week nine, he/she shall be referred to the DOCS to determine if that candidate should be rolled from their current class for additional swim remediation. Candidates will not commission without passing the third class swim qualification.

457. Performance Documentation. An Unsatisfactory Performance Report (UPR) shall be completed when a candidate fails any performance standard detailed above. Candidates shall review the UPR, make comments, and sign it.

458. Repeated Poor Performance. Candidates who fail multiple training events are subject to counseling, extra instruction, review of their progress by the DOCS, or a PRB.

459. PRT Standards

Physical Readiness Test (PRT) Chart for Males: 20-24 Years of Age.				
Performance Level	Points	Curl-ups	Push-ups	1.5-mile run
Maximum	100	105	87	8:30
Outstanding	90	98	81	9:15
Excellent	75	87	71	10:30
Good	60	58	47	12:00
Satisfactory	45	46	37	13:30

Physical Readiness Test (PRT) Chart for Males: 25-29 Years of Age.				
Performance Level	Points	Curl-ups	Push-ups	1.5-mile run
Maximum	100	101	84	8:55
Outstanding	90	95	77	9:38
Excellent	75	84	67	10:52
Good	60	54	44	12:53
Satisfactory	45	43	34	14:00

Physical Readiness Test (PRT) Chart for Males: 30-34 Years of Age.				
Performance Level	Points	Curl-ups	Push-ups	1.5-mile run
Maximum	100	98	80	9:20
Outstanding	90	92	74	10:00
Excellent	75	81	64	11:15
Good	60	51	41	13:45
Satisfactory	45	40	31	14:30

Physical Readiness Test (PRT) Chart for Males: 35-39 Years of Age.				
Performance Level	Points	Curl-ups	Push-ups	1.5-mile run
Maximum	100	95	76	9:25
Outstanding	90	88	70	10:08
Excellent	75	78	60	11:23
Good	60	47	37	14:08
Satisfactory	45	37	27	15:00

Table 4.1

Physical Readiness Test (PRT) Chart for Females: 20-24 Years of Age.				
Performance Level	Points	Curl-ups	Push-ups	1.5-mile run
Maximum	100	105	48	9:47
Outstanding	90	98	44	11:30
Excellent	75	87	39	13:15
Good	60	58	21	14:15
Satisfactory	45	46	16	15:30

Physical Readiness Test (PRT) Chart for Females: 25-29 Years of Age.				
Performance Level	Points	Curl-ups	Push-ups	1.5-mile run
Maximum	100	101	46	10:17
Outstanding	90	95	43	11:45
Excellent	75	84	37	13:23
Good	60	54	19	14:53
Satisfactory	45	43	13	16:08

Physical Readiness Test (PRT) Chart for Females: 30-34 Years of Age.				
Performance Level	Points	Curl-ups	Push-ups	1.5-mile run
Maximum	100	98	44	10:46
Outstanding	90	92	41	12:00
Excellent	75	81	35	13:30
Good	60	51	17	15:30
Satisfactory	45	40	11	16:45

Physical Readiness Test (PRT) Chart for Females: 34-39 Years of Age.				
Performance Level	Points	Curl-ups	Push-ups	1.5-mile run
Maximum	100	95	43	10:51
Outstanding	90	88	39	12:08
Excellent	75	78	34	13:45
Good	60	47	14	15:53
Satisfactory	45	37	9	17:00

Table 4.1 (Cont'd)

SECTION 6 - CANDIDATE ACHIEVEMENTS

461. Class Achievements. Companies can achieve team recognition by earning competitive streamers to be affixed to the Company Guideon. Averages will be computed based on the raw scores of candidates in the company at the time the final graded event is completed for that competitive category. Averages shall not be rounded to the nearest integer. In the event of a dual company class, the company with the higher qualifying score will be awarded the respective streamer. The competitive categories are:

a. Drill Streamer. A red streamer with gold lettering awarded in the fifth week. A company must achieve a drill evaluation score of 83 points (i.e. 83%) or higher on the Drill Evaluation.

b. RLP (Room, Locker, Personnel) Streamer. A purple streamer with white lettering. The RLP streamer is awarded when a company achieves a minimum class average of 82 (with no more than 1/3 failures).

c. PT (Physical Training) Streamer. A black streamer with white lettering. The PT streamer is awarded when a company achieves a minimum average of 90 points or higher on the Out-PFA.

d. PI (Personnel Inspection) Streamer. A yellow streamer with red lettering. A PI Streamer is awarded when a company achieves a combined average of 88% (with no more than 20% failures) on the Sixth Week PI and OPI.

e. Academic Streamer. A green streamer with yellow lettering. The Academic Streamer is awarded when a company achieves a minimum average of 88% in all academic classes.

462. Honor Class/Honor Company

a. A yellow streamer with black lettering is awarded to companies that have demonstrated sustained superior performance at OCS by attaining all five streamers and the Class Teams' recommendation.

b. If only one company in a double company class attains the minimum scores required to qualify for all five streamers, then that company will be recognized as an Honor Company.

3 Jul 14

c. If both companies of a double company class attain the minimum scores required for all the streamers then the entire class will be recognized as an Honor Class.

463. Individual Candidate Achievements

a. Recognition Awards. Individual excellence awards recognize superior candidate performance. A candidate may earn multiple awards.

(1) Academics. Awarded to candidates with an academic average in the top 10% (rounded up to the nearest whole number) of the class.

(2) PT. Awarded to Candidates with a score greater than 95% on the Mid-PFA.

(3) Military. Awarded to candidates in the top 10% (rounded up to the nearest whole number) of the class for military inspections and have accrued less than 10 demerits.

(4) "Snowflake" distinction: Awarded to candidates who achieved excellence in every individual competitive category.

b. Distinguished Naval Graduates. A candidate meeting the following criteria shall be recognized as a Distinguished Naval Graduate at the graduation ceremony:

(1) An overall average in the top 10% (rounded up to the nearest whole number) of the graduating class.

(2) Accrued less than 10 demerits.

CHAPTER 5
UNIFORMS AND GEAR

SECTION 1 - PERSONAL APPEARANCE AND UNIFORMS

511. General Requirements and Information. The following regulations apply to all OCS students.

a. Appearance. The highest standards of personal and military appearance shall be maintained at all times. As an ambassador for the Navy and our Nation it is your responsibility to ensure that hair/grooming/personal appearance while in uniform present a neat, professional appearance.

b. Personal Hygiene. Personal hygiene includes but is not limited to: dental hygiene, daily shower, and hand sanitizing at every afforded opportunity. Good hygiene is one of the greatest factors in keeping candidates healthy to achieve maximum mission readiness.

c. Cosmetics (Women). Conservative make-up, in moderation, is authorized for use by candidates while on leave or liberty during the Candidate Officer phase of training. Cosmetics may be applied in good taste so that colors blend with natural skin tone and enhance natural features. Exaggerated or faddish cosmetic styles are not authorized with the uniform and shall not be worn. Care should be taken to avoid an artificial appearance. Lipstick colors shall be conservative and complement the individual. Long false eyelashes shall not be worn when in uniform.

d. Jewelry. Jewelry, with the exceptions below, is unauthorized while training at OCS.

(1) Rings. Only the wedding band is authorized at OCS.

(2) Necklaces. No necklaces are authorized throughout all of training. However, a single religious medallion, no larger than a dog tag, is authorized to be worn on a large dog tag chain.

(3) Wristwatches. During phase one of training, only the class president, vice-president, adjutant, medical body and daily section leader shall be authorized wristwatch privileges. Upon the beginning of phase two of training wristwatches are

3 Jul 14

authorized to be worn by all candidates. Wristwatches will be in accordance with Naval Uniform Regulations

(4) Earrings (Women). Earrings are authorized only during the Candidate Officer phase of training. Only one earring per ear (centered on the earlobe) is authorized in uniform except while wearing PT Gear. See paragraph 532 for additional guidance.

e. Glasses. Candidates with an eyeglass prescription who have not been issued eyeglasses from Navy Medicine or who had their issued eyeglasses broken shall be allowed to wear personal eyeglasses. Once a candidate has been issued a pair of eyeglasses, that candidate shall wear only the issued eyeglasses. Contact lenses are only authorized during Candi-O phase.

512. Grooming Standards

a. Hair. Keep hair neat, clean, and well groomed. Candidates will only use the NEX Barbershops for haircuts until authorized off base liberty.

(1) Indoctrination and Officer Candidates

(a) Men. Candidates will have a "shaved" buzz cut type haircut until the successful completion of the Sixth Week PI. Thereafter they will comply with U.S. Navy Uniform Regulations Art. 2201.1.

(b) Women. Hair is expected to be in regulations from reveille to taps. This includes events such as: PT, First Friday, etc.) When in uniform, the hair may touch, but not fall below a horizontal line level with the lower edge of the back of the collar. Long hair, including braids, which fall below the lower edge of the collar shall be neatly and inconspicuously fastened, pinned, or secured to the head. No portion of the bulk of the hair as measured from the scalp will exceed approximately 2 inches. Hairstyles shall not be outrageously multicolored or faddish, to include shaved portions of the scalp (other than the neckline), or have designs cut or braided into the hair.

1 Coloring. Hair coloring must look natural and complement the individual.

3 Jul 14

2 Style. Haircuts and styles shall present a balanced appearance. Lopsided and extremely asymmetrical styles are not authorized. Ponytails, pigtails, widely spaced individual hanging locks, and braids which protrude from the head, are not authorized. Multiple braids are authorized. Braided hairstyles shall be conservative and conform to the guidelines listed herein. When a hairstyle of multiple braids is worn, braids shall be of uniform dimension, small in diameter (approx. 1/4 inch), and tightly interwoven to present a neat, professional, well groomed appearance. Foreign material (i.e., beads, decorative items) shall not be braided into the hair. Short hair may be braided in symmetrical fore and aft rows (corn rowing) which minimize scalp exposure. Corn row ends shall not protrude from the head, and shall be secured only with inconspicuous rubber bands that match the color of the hair. Appropriateness of a hairstyle shall also be judged by its appearance when headgear is worn.

3 Headgear. All headgear shall fit snugly and comfortably around the largest part of the head without distortion or excessive gaps. Hair shall not show from under the front of the brim of the combination hat, garrison, or 8 point cover. Hairstyles which do not allow headgear to be worn in this manner, or which interfere with the proper wear of protective masks or equipment are prohibited.

4 Hair Pinning Items. A maximum of two small snap barrettes or elastic pony tail holders, similar to hair color, may be used in the hair. Hair ornaments shall not present a safety or FOD (Foreign Object Damage) hazard.

5 Hair Products. Acceptable hair products are gels, mousse, and spray to allow hair to be maintained within grooming standards.

(2) Candidate Officers. Candidate Officers shall keep their hair in accordance with U.S. Navy Uniform Regulations Art. 2201.1.

b. Shaving and Mustaches (Men). Male candidates shall always be clean shaven. Some candidates may experience shaving disorders, therefore, the use of electric shavers is authorized with the following stipulations:

(1) Candidates diagnosed by a medical provider with pseudo-folliculitis barbae (razor bumps) shall comply with the treatment program prescribed by the physician and keep a copy of

3 Jul 14

the medical chit with them at all times (in the left breast pocket while in uniform).

(2) No shaver will be left adrift or plugged in for recharge. If not in use, the shaver will be stowed in the wall locker personal gear box.

(3) No sharing of electric shavers.

(4) Indoctrination staff will inspect new arrivals' electric shavers for serviceability.

c. Fingernails

(1) Men. Fingernails will be kept clean and shall not exceed the fingertip.

(2) Women. Fingernails will be kept clean and shall not exceed 1/4-inch measured from the fingertip. Nail polish may be worn on leave or liberty during the Candidate Officer phase but colors shall be conservative and complement the skin tone.

513. Uniform Standards

a. Wearing of Uniform. Only authorized uniforms shall be worn. The Uniform of the Day is prescribed by the Regimental Commander daily at reveille and is posted in various locations throughout Nimitz Hall.

(1) Indoctrination Candidates.

(a) The Navy Physical Training Uniform (PTU) will be worn at all times following initial issue until completion of First Friday. The All Weather coat may be worn during Inclement Weather conditions. Reflective belts will be worn at all times during the Indoctrination Phase.

(b) Following First Friday until the successful completion of Fast Cruise, Indoctrination Candidates will wear the Navy Working Uniform (NWU) during normal working hours with boots unbloused.

(c) Following Fast Cruise, Indoctrination Candidates will wear the Navy Working Uniform (NWU) during normal operating hours.

3 Jul 14

(2) Officer Candidates

(a) Normal Operating Hours. The Navy Working Uniform (NWU) is the prescribed uniform during normal operating hours. Officer Candidates shall wear a reflective belt with the NWU at all times with the exception of preparing for and during some MTTs (Military Training Tests) and in a Classroom.

(b) Non-operating Hours. Non-operating Hours are defined as those hours following evening chow in which no other events are scheduled on the Plan of the Day. During non-operating hours the NWU or PTU are authorized to be worn in Nimitz Hall. Officer Candidates preparing for MTTs may wear that evolutions uniform during non-operating hours. The PTU includes blue Navy shorts, gold Navy t-shirt, solid white athletic socks, and running shoes. Navy sweat tops/bottoms, watch caps, and gloves will be prescribed for inclement weather. A reflective belt will be worn at all times with the PT uniform.

(c) Drill Uniform. The prescribed drill uniform is the NWU.

(3) Candidate Officers

(a) Service Khaki. Candidate Officers will wear Service Khaki or other prescribed uniform of the day. The Service Khaki uniform may be worn off base when conducting official OCS business and when on liberty.

(b) PT Uniform. A class PT shirt and sweat top are authorized in place of the Navy PT shirt and sweat top. The PTU is authorized if actively engaged in physical training or a training evolution where PT gear is.

(4) Pre-Graduation Reception Uniform

(a) Candidates will wear the Summer White uniform during the summer months and Service Dress Blues (SDB) during winter months. The Ensign Rank stripe on the sleeve of will be covered.

(b) Both uniforms are authorized to wear on liberty following the pre-graduation reception.

(5) Ceremonial Uniforms. Full Dress Blues or Full Dress Whites will be worn for the graduation ceremony.

3 Jul 14

Candidate officer insignia shall not be worn. The combination cover will be carried outdoors prior to the graduation.

(6) Religious Services Uniform. When attending on-base religious services, Officer Candidates shall wear the NWU. Candidate Officers may wear Service Khaki. Students in H-Class will wear the uniform appropriate to the level of training completed. Candidates who have been authorized to attend off-base religious services will wear the following: NWU during weeks one through eight of training and service khaki after week eight of training.

b. Alterations. A garment's intended appearance or function shall not be changed. Wearing improperly altered clothes is prohibited.

(1) Tucks. Un-tapered shirts shall be worn neatly folded on each side of the small of the back and tucked into trousers.

(2) Unsecured threads/strings. All unsecured threads/strings will be removed from the outside of all uniform articles. Threads/strings will also be removed from the inside waistband of trousers.

c. Headgear. A cover shall be worn at all prescribed times with the exception that it may be removed while driving on/off base if the cover impedes driving ability.

(1) NWU Cover. When not covered, the NWU 8-point Cover shall be neatly stored in the starboard trouser cargo pocket or carried in the same manner as the Combination Cover.

(2) Combination Covers. Combination Covers shall be carried in the left hand, forearm parallel to the deck, palm up. The cover shall rest in the hand right side up with the visor resting in the first joints of the fingers and the thumb inside the cover. The fingers shall be bent slightly to maintain a grip on the cover.



Figure 5.1

d. Pockets. Candidates shall carry their Armed Forces Common Access Card (ID Card) or Government issued ID and any active medical charts in the buttoned port breast pocket of the shirt or blouse at all times. When in uniform, hands shall not be placed in pockets. Do not carry items that protrude from the pockets.

514. Purchasing Uniform Items

a. Candidates are responsible for purchasing all uniform items listed in tables 5.1 and 5.2. Candidates that brought previously owned uniform items shall have them assessed for serviceability and fitting by Uniform Shop personnel during initial or second issue.

(1) Candidates will be issued items in table 5.1 on check-in Sunday (exceptions may occur).

(2) Candidates will be issued items in table 5.2 during their corresponding uniform issue (exceptions may occur).

b. Items not available at the time of purchase will be placed on special order by the NEX Uniform Shop. The special order list shall be made available to the Class Team.

(1) The Indoctrination Staff shall provide the special order list during Initial Uniform Issue.

(2) The class adjutant/RLP Body shall provide the special order list during Second Uniform Issue.

c. Candidates will be provided time throughout training by the Class Team to purchase additional or replace damaged uniform items.

3 Jul 14

UNIFORM SHOP ISSUE	INITIAL ISSUE	SECOND ISSUE
MEN'S SDB JACKET *		X
MEN'S SDB TROUSER *		X
MEN'S WHITE DRESS SHIRT *		X
MEN'S SDW JACKET		X
MEN'S WHITE CNT SHIRT		X
MEN'S WHITE CNT TROUSER		X
MEN'S KHAKI SHIRT (2)		X
MEN'S KHAKI TROUSER (2)		X
WOMEN SDB JACKET		X
WOMEN SDB SLACKS (UNBELTED)		X
WOMEN WHITE DRESS SHIRT *		X
WOMEN SDW JACKET		X
WOMEN SDW SLACKS(UNBELTED)		X
WOMEN WHITE CNT SHIRT		X
WOMEN WHITE SLACKS (BELTED)		X
WOMEN KHAKI SHIRT (2)		X
WOMEN KHAKI SLACKS (2)		X
SHOULDER BOARDS, SOFT		X
SHOULDER BOARDS HARD		X
RIBBON BAR		X
NATIONAL DEFENSE MEDAL (LARGE)		X
OFFICER LARGE CAP DEVICE WITH BAND		X
GOLD OFFICER CHIN STRAP		X
ENSIGN KIT (LINE, SUPPLY, CIV ENG)		X
GOLD LACE (FEMALE) (2)		X
BLACK AND WHITE SLEEVE DEVICE AND ½" GOLD LACE		X

* Uniform component also available as a "PREMIER UNIFORM". Upgrade of basic components to the "PREMIER UNIFORM" brand is voluntary.

** Blue T-shirts will be issued by uniform shop as available (SOFFE 3 pk or DSCP)(1). Hanes blue t-shirt 4pk is not authorized for wear at OCS unless it is issued by uniform shop.

*** Athletic shoes are sold at NEX. Only candidates authorized by medical or OTCN staff will purchase this item during "uniform issue days"

Table 5.1

3 Jul 14

KING HALL ISSUE (IN ROOM PRIOR TO ARRIVAL)
POCKET NOTEBOOK
2 PACK PENS
CANTEEN
MESH LAUNDRY BAG
SEA BAG
REFLECTIVE BELT
LOCKS (2 PACK)
SHOWER SHOES
KING HALL ISSUE (SUNDAY OF ARRIVAL)
SEWING KIT
BLACK PEN 10 PACK
BLACK LAUNDRY PEN
SINGLE NOTEBOOK
WOOD RULER OR SUITABLE SUBSTITUTE
YELLOW HIGHLIGHTER 2 PACK
SCOTCH TAPE
MECHANICAL PENCIL
MEMO PAD
STATIONARY KIT
MARKING/STAMPING KIT
NAIL SCISSORS
TOE NAIL CLIPPERS
SHOE POLISH KIT
COTTON SWABS
WHITE TOWEL (2)
WASH CLOTH (2)
SHOE POLISH KIT
COTTON SWABS
UNIFORM ITEMS (SUNDAY OF ARRIVAL)
ALL WEATHER COAT
WHITE SOCKS (6 PACK)
PTU SHORTS 6" OR 8" (3)
NAVY SWEAT PANTS (2)
NAVY SWEAT SHIRT (W/HOOD) (2)
NAVY PTU S/S SHIRTS (3 SUMMER/ 2 WINTER)
NAVY PTU L/S SHIRTS (2 SUMMER/ 3 WINTER)
WATCH CAP (SEASONAL)
GLOVES (SEASONAL)

Table 5.2

3 Jul 14

SECTION 2 - UNIFORM COMPONENTS521. Uniform Components

a. Basic Uniform Components. The minimum items which shall be worn unless the prescribing authority directs otherwise.

b. Prescribable Items. Uniform items which may be directed or authorized for wear with the basic uniform. Prescribable items may be worn with the basic uniform at the Regimental Commander or OCS competent authority discretion unless otherwise directed.

c. Optional Items. Uniform items purchased at the candidate's expense, which may be worn with the basic uniform, but which are not prescribable. Optional items may be worn with the basic uniform at the Regimental Commander or OCS competent authority discretion unless otherwise directed.

3 Jul 14



d. Navy Working Uniform (NWU)
Male

BASIC UNIFORM COMPONENTS ARTICLE

Shirt, NWU	532.p
Trousers, NWU	532.bb
Cap, Eight Point	532.f
Boot, Black, Leather	532.t
Socks, Black, Boot	532.w
Undershirt, Cotton, Blue	532.ee
Undershorts	532.gg
Belt, Khaki Cotton w/Gold	532.b
Clip Buckle, Gold	532.d
Insignia, Collar	541.c
Name/U.S. NAVY Service Tapes	
	541.b
Straps, Blousing	532.jj

PRESCRIBABLE ITEMS

Coat, Parka (w/Black Fleece Liner)	532.1
Cap, Knit (Watch), Black	532.11

OPTIONAL ITEMS

Gloves, Black Leather	532.j
-----------------------	-------

OCCASIONS FOR WEAR

Worn year-round after Admin Week and when authorized during the Candidate Officer/Applied Leadership phase. The NWU is authorized for off-base religious services in weeks one through eight.

3 Jul 14



e. Navy Working Uniform (NWU)
Female

BASIC UNIFORM COMPONENTS ARTICLE

Shirt, NWU	532.p
Trousers, NWU	532.bb
Cap, Eight Point	532.f
Boot, Black, Leather	532.t
Socks, Black, Boot	532.w
Undershirt, Cotton, Blue	532.ee
Brassiere	532.c
Underpants	532.dd
Belt, Khaki, Cotton w/Gold Clip	532.b
Buckle, Gold	532.d
Insignia, Collar	541.c
Name/U.S. NAVY Service Tapes (Identification Markings)	541.b
Straps, Blousing	532.jj

PRESCRIBABLE ITEMS

Coat, Parka (w/Black Fleece Liner)	532.l
Cap, Knit (Watch), Black	532.ll

OPTIONAL ITEMS

Gloves, Black Leather	532.j
-----------------------	-------

OCCASIONS FOR WEAR

Worn year-round after Admin Week and when authorized during the Candidate Officer/Applied Leadership phase. The NWU is authorized for off-base religious services in weeks one through eight.

3 Jul 14

f. Summer White - Male

BASIC UNIFORM COMPONENTS ARTICLE

Shirt, White, Summer	532.r
Trousers, White	532.cc
Cap, Combination, White	532.e
Shoes, Service, White	532.s
Socks, White	532.w
Undershirt, White	532.ff
Undershorts	532.gg
Belt, White, w/Gold Clip	532.b
Buckle, Gold	532.d
Shoulder Boards (Hard)	541.d
Ribbons	541.h

PRESCRIBABLE ITEMS

All Weather Coat, Blue	532.a
------------------------	-------

OPTIONAL ITEMS

Jacket, Black	532.k
Name/Identification Tag	541.b

OCCASIONS FOR WEAR

Worn in the summer for the OPI inspection and the Pre-Graduation Reception.

3 Jul 14

g. Summer White - Female

BASIC UNIFORM COMPONENTS ARTICLE

Shirt, White, Summer	532.r
Slacks, White, Belted	532.v
Cap, Combination, White	532.e
Shoes, Service, White	532.s
Socks, White	532.w
Brassiere	532.c
Underpants	532.dd
Belt, White, w/Gold Clip	532.b
Buckle, Gold	532.d
Shoulder Boards (Hard)	541.d
Ribbons	541.h

PRESCRIBABLE ITEMS

All Weather Coat, Blue	532.a
Undershirt, White	532.ff

OPTIONAL ITEMS

Name/Identification Tag	541.b
Jacket, Black	532.k
Earrings, Gold Ball	532.i

OCCASIONS FOR WEAR

Worn in the summer for the OPI inspection and the pre-graduation reception.

3 Jul 14

h. Service Khaki - Male

BASIC UNIFORM COMPONENTS ARTICLE

Shirt, Khaki, Service	532.o
Trousers, Khaki, Service	532.aa
Cap, Combination, Khaki	532.e
Shoes, Dress, Black	532.s
Socks, Black	532.w
Undershirt, White	532.ff
Undershorts	532.gg
Belt, Khaki, w/Gold Clip	532.b
Buckle, Gold	532.d
Insignia, Collar	541.c
Ribbons	541.h

PRESCRIBABLE ITEMS

All Weather Coat, Blue	532.a
Cap, Garrison, Khaki	532.kk

OPTIONAL ITEMS

Jacket, Black	532.k
Name/Identification Tag	541.b

OCCASIONS FOR WEAR

Worn year round during Candidate Officer Phase and liberty.

3 Jul 14

i. Service Khaki - Female

BASIC UNIFORM COMPONENTS ARTICLE

Shirt, Khaki, Service	532.o
Slacks, Khaki, Service	532.u
Cap, Combination, Khaki	532.e
Shoes, Service, Black	532.s
Socks, Black	532.w
Brassiere	532.c
Underpants	532.dd
Belt, Khaki, w/Gold Clip	532.b
Buckle, Gold	532.d
Insignia, Collar	541.c
Ribbons	541.h

PRESCRIBABLE ITEMS

All Weather Coat, Blue	532.a
Undershirt, White	532.ff
Cap, Garrison, Khaki	532.kk

OPTIONAL ITEMS

Jacket, Black	532.k
Earrings, Gold Ball	532.i
Name/Identification Tags	541.b

OCCASIONS FOR WEAR

Worn year round during Candidate Officer Phase and liberty.

3 Jul 14

j. Service Dress Blue - Male

BASIC UNIFORM COMPONENTS ARTICLE

Coat, Service Dress Blue	532.g
Shirt, White, Dress	532.q
Trousers, Blue, Dress	532.z
Cap, Combination, White	532.e
Shoes, Dress, Black	532.s
Socks, Black	532.w
Undershirt, White	532.ff
Undershorts	532.gg
Belt, Black, w/Gold Clip	532.b
Necktie, Black, Four-in-Hand	532.n
Buckle, Gold	532.d
Ribbons	541.h

PRESCRIBABLE ITEMS

All Weather Coat, Blue	532.a
Gloves, White	532.j
Insignia, Rank	541.e

OPTIONAL ITEMS

Jacket, Black	532.k
Tie Clasp/Tack	532.y
Name/Identification Tags	541.b

OCCASIONS FOR WEAR

Worn during winter, OPI (Officer Personnel Inspection) and the pre-graduation reception.

3 Jul 14

k. Service Dress Blue - Female

BASIC UNIFORM COMPONENTS ARTICLE

Coat, Service Dress Blue	532.g
Shirt, White, Dress	532.q
Slacks, Blue, Unbelted	532.hh
Cap, Combination, White	532.e
Shoes, Service, Black	532.s
Socks, Black	532.w
Brassiere	532.c
Underpants	532.dd
Necktie (necktab), Black	532.m
Ribbons	541.h

PRESCRIBABLE ITEMS

All Weather Coat, Blue	532.a
Gloves, Black/White	532.j
Insignia, Rank	541.e
Undershirt, White	532.ff

OPTIONAL ITEMS

Earrings, Gold Ball	532.i
Jacket, Black	532.k

OCCASIONS FOR WEAR

Worn during winter for OPI inspection and the pre-graduation reception.

3 Jul 14



1. Full Dress Blue - Male

BASIC UNIFORM COMPONENTS ARTICLE

Coat, Service Dress Blue	532.g
Shirt, White, Dress	532.q
Trousers, Blue, Dress	532.z
Cap, Combination, White	532.e
Shoes, Dress, Black	532.s
Socks, Black	532.w
Undershirt, White	532.ff
Undershorts	532.gg
Belt, Black, w/Gold Clip	532.b
Buckle, Gold	532.d
Gloves, White	532.j
Necktie, Black, Four-in-Hand	532.n
Large Medals/Ribbons	541.h

PRESCRIBABLE ITEMS

All Weather Coat, Blue	532.a
Insignia, Rank	541.e

OPTIONAL ITEMS

Tie Clasp/Tack	532.y
----------------	-------

OCCASIONS FOR WEAR

Worn during winter for the graduation ceremony.

3 Jul 14

m. Full Dress Blue - Female

BASIC UNIFORM COMPONENTS ARTICLE

Coat, Service Dress Blue	532.g
Shirt, White, Dress	532.q
Slacks, Blue, Unbelted	532.hh
Cap, Combination, White	532.e
Shoes, Service, Black	532.s
Socks, Black	532.w
Brassiere	532.c
Underpants	532.dd
Gloves, White	532.j
Necktie, (necktab) Black	532.m
Large Medals/Ribbons/	541.h

PRESCRIBABLE ITEMS

All Weather Coat, Blue	532.a
Insignia, Rank	541.e
Undershirt, White	532.ff

OPTIONAL ITEMS

Earrings, Gold Ball	532.i
Jacket, Black	532.k

OCCASIONS FOR WEAR

Worn during winter for the graduation ceremony.

3 Jul 14



n. Full Dress White - Male

BASIC UNIFORM COMPONENTS ARTICLE

Coat, Service Dress White	532.h
Trousers, White	532.cc
Cap, Combination, White	532.e
Shoes, Dress, White	532.s
Socks, White	532.w
Undershirt, White	532.ff
Undershorts	532.gg
Belt, White, w/Gold Clip	532.b
Gloves, White	532.j
Buckle, Gold	532.d
Shoulder Boards (Hard)	541.d
Large Medals/Ribbons	541.h

PRESCRIBABLE ITEMS

All Weather Coat, Blue
532.a

OCCASIONS FOR WEAR

Worn during summer for the graduation ceremony.

3 Jul 14



o. Full Dress White - Female

BASIC UNIFORM COMPONENTS ARTICLE

Coat, Service Dress White	532.h
Shirt, White, Dress	532.q
Slacks, White, Unbelted	532.ii
Cap, Combination, White	532.e
Shoes, Service, White	532.s
Socks, White	532.w
Brassiere	532.c
Underpants	532.dd
Gloves, White	532.j
Necktie (necktab), Black	532.m
Large Medals/Ribbons	541.h

PRESCRIBABLE ITEMS

All Weather Coat, Blue	532.a
Insignia, Rank	541.e
Undershirt, White	532.ff

OPTIONAL ITEMS

Earrings, Gold Ball	532.i
---------------------	-------

OCCASIONS FOR WEAR

Worn during summer for the graduation ceremony.

3 Jul 14

o. Dinner Dress Blue - Male

BASIC UNIFORM COMPONENTS	ARTICLE
Coat, Service Dress Blue	532.h
Shirt, White, Dress	532.u
Trousers, Blue, Dress	532.dd
Cap, Combination, White	532.f
Shoes, Dress, Black	532.w
Socks, Black	532.aa
Undershirt, White	532.ii
Undershorts	532.kk
Belt, Black, w/Gold Clip	532.b
Necktie, Bow, Black	532.q
Buckle, Gold	532.d
Miniature Medals	541.h

PRESCRIBABLE ITEMS

All Weather Coat, Blue	532.a
Gloves, White	532.k
Rank Insignia	541.e

Occasions For Wear

Worn during winter for Dining-In, Dining-Out, and the Navy Birthday Ball.

3 Jul 14

p. Dinner Dress Blue - Female



BASIC UNIFORM COMPONENTS ARTICLE

Coat, Service Dress Blue	532.h
Shirt, White, Dress	532.u
Slacks, Blue, Unbelted	532.ll
Cap, Combination, White	532.f
Shoes, Service, Black	532.w
Socks, Black	532.aa
Brassiere	532.c
Underpants	532.hh
Necktab, Dress, Black	532.p
Miniature Medals	541.h

PRESCRIBABLE ITEMS

All Weather Coat, Blue	532.a
Gloves, White	532.k
Rank Insignia	541.e

OPTIONAL ITEMS

Handbag, Black	532.m
Earrings, Pearl	532.j

Occasions For Wear

Worn during winter for Dining-In, Dining-Out, and the Navy Birthday Ball.

3 Jul 14

q. Dinner Dress White - Male

BASIC UNIFORM COMPONENTS	ARTICLE
Coat, Service Dress White	532.i
Trousers, White	532.gg
Cap, Combination, White	532.f
Shoes, Dress, White	532.w
Socks, White	532.aa
Undershirt, White	532.ii
Undershorts	532.kk
Belt, White, w/Gold Clip	532.b
Buckle, Gold	532.d
Shoulder Boards (Hard)	541.d
Miniature Medals	541.h

PRESCRIBABLE ITEMS

All Weather Coat, Blue	532.a
Gloves, White	532.k

Occasions For Wear

Worn during summer for Dining-In or Dining-Out.

3 Jul 14



r. Dinner Dress White - Female

BASIC UNIFORM COMPONENTS ARTICLE

Coat, Service Dress White	532.i
Shirt, White, Formal	532.u
Slacks, White, Unbelted	532.mm
Cap, Combination, White	532.f
Shoes, Service, White	532.w
Socks, White	532.aa
Brassiere	532.c
Underpants	532.hh
Necktab, Black	532.p
Miniature Medals	541.h

PRESCRIBABLE ITEMS

All Weather Coat, Blue	532.a
Gloves, White	532.k
Rank Insignia	541.e

OPTIONAL ITEMS

Handbag, White Dress	532.m
Earrings, Pearl	532.j

Occasions For Wear

Worn during summer for Dining-In
or Dining-Out.

3 Jul 14



p. PT Uniform - Male

BASIC UNIFORM COMPONENTS ARTICLE

Shirt, PTU (Short Sleeve), Gold	532.mm.(1)
Shorts, PTU, Blue	532.mm.(2)
*Shoes, Athletic	532.mm.(3)
Socks, Athletic white	532.mm.(4)
Undershorts	532.gg

PRESCRIBABLE ITEMS

Same as Basic Uniform Components

OPTIONAL ITEMS

Cap, Knit (Watch)	532.11
Shirt, PTU (Long Sleeve), Gold	532.mm.(1)
Shirt, Sweat, Navy	532.mm.(5)
Pants, Sweat, Navy	532.mm.(6)

OCCASIONS FOR WEAR

The PTU is designed for group/unit physical training activities and the Physical Fitness Assessment (PFA). The PTU will also be worn while engaging in working parties or cleaning.

** Minimalist footwear is not authorized during any OCS training evolution.*



3 Jul 14



q. PT Uniform (Female)

BASIC UNIFORM COMPONENTS ARTICLE

Shirt, PTU (Short Sleeve), Gold	532.mm.(1)
Shorts, PTU, Blue	532.mm.(2)
*Shoes, Athletic	532.mm.(3)
Socks, Athletic	532.mm.(4)
Brassiere, (Women)	532.c
Underpants	532.dd

PRESCRIBABLE ITEMS

Same as Basic Uniform Components

OPTIONAL ITEMS

Brassiere, Sports	532.c
Cap, Knit (Watch)	532.ll
Shirt, PTU (Long Sleeve), Gold	532.mm.(1)
Shirt, Sweat, Navy	532.mm.(5)
Pants, Sweat, Navy	532.mm.(6)

OCCASIONS FOR WEAR

The PTU is designed for group/unit physical training activities and the Physical Fitness Assessment (PFA). The PTU will also be worn while engaging in working parties or cleaning.

** Minimalist footwear is not authorized during any OCS training evolution.*



3 Jul 14

SECTION 3 - DESCRIPTION AND WEAR OF UNIFORM COMPONENTS

531. Ownership Markings. Markings shall be a stencil consisting of owner's last name, first initial and middle initial (i.e. SAILOR, I. M.) placed inside the garment as outlined in this section unless otherwise directed. Stencil letters shall be approximately 3/8 inch blocked letters. Markings shall be black on white uniform items, and white on dark uniform items. When marking on a manufacturer label, the last name, first name and middle initial is printed on the "name" line with a black ball point pen. The Service No. line will only be used for candidates who have the same last name and initials. Some manufacturer labels do not contain a space for "Name". In this instance mark the name in an available space on the label (must be uniform throughout the class). All Uniform items improperly marked shall be corrected by drawing a single line through the error and re-marking the area immediately above it. Candidates are discouraged from purchasing new items to correct marking errors.

Caution: Using excessive amounts of ink may cause it to bleed through the uniform. Use caution when marking uniform items.

Note: The term "seam" refers to the stitching of any hem.

532. Description and Wear of Uniform Componentsa. All-Weather Coat, Blue

(1) Description. A black, single-breasted, beltless, water repellent coat made of 65%/35% poly/cotton poplin fabric. The coat has epaulets, tabs on cuffs, and a zip-out lining. Women's coat buttons to the left and men's coat buttons to the right.

(2) Correct Wear. Button all buttons except the top collar/breast button (3/4" button). Port collar "trench button" (1/2" button) will be buttoned to the portside when not in use (i.e. RLP inspection). The top collar/breast button will be buttoned in inclement weather. Insignia is worn in accordance with article 541.h.

(3) Ownership Markings. Liner: Inside on the back of the lining, *centered* 3 inches below collar seam. Shell: Inside on outer shell on manufacturer's tag.

3 Jul 14

b. Belt with Gold Clip

(1) Description. A cotton or nylon web belt may be worn with all uniforms. Plain cloth or webbing, same color as uniform, 1-1/4-inch wide (men), 1 inch wide (women), and fitted with a gold clip. If a cloth belt is worn, fabric shall match the uniform. NOTE: Both male and female candidates will wear the 1-1/4-inch wide khaki belt with the Navy Working Uniform (NWU).

(2) Correct Wear. Wear the belt through all belt loops. Men wear the belt with the clip to the left of the buckle and women wear the belt with the clip to the right of the buckle and grounded to the edge of the buckle. Both males and females wear the belt clip to the left of the buckle when wearing NWUs. Belt excess should be from two to four inches measured from the belt's claw hinge.

(3) Ownership Markings. First, Middle, and Last Name Initials shall be placed inside belt near the clip. Center the marking from left to right half an inch from the belt clip, reading left to right.

c. Brassiere (Women)

(1) Description. Shall be white or wearer's skin tone when worn with white shirts, otherwise, color is optional. Athletic brassieres (Sports Bras) are highly recommended for daily wear and athletics. However, for uniform issue, inspections and liberty uniforms a regular brassiere is recommended.

(2) Correct Wear. Wear right side out with all fasteners secured.

(3) Ownership Markings. Brassiere will be marked on the inside, back and centered, close to the bottom edge. Last name, first initial and middle initial in black ink for white and lighter colored brassieres and white ink for darker colored brassieres.

d. Buckle, Gold

(1) Description. A plain gold anodized Navy belt buckle.

(2) Correct Wear

(a) Men. Worn with the belt clip grounded to the LEFT side of the buckle. Align the right side of the buckle with the opening of the shirt and top opening of the fly forming a straight line. The spindle shall be vertical and grounded in the fully locked position to the extreme right with the top portion of the spindle grounded to the top of the buckle. See figure 5.3.

(b) Women. Worn with the belt clip grounded to the RIGHT side of the buckle. Align the left side of the buckle with the opening of the shirt forming a straight line. The spindle shall be vertical and grounded in the fully locked position to the extreme left with the top portion of the spindle grounded to the top of the buckle. See figure 5.2.

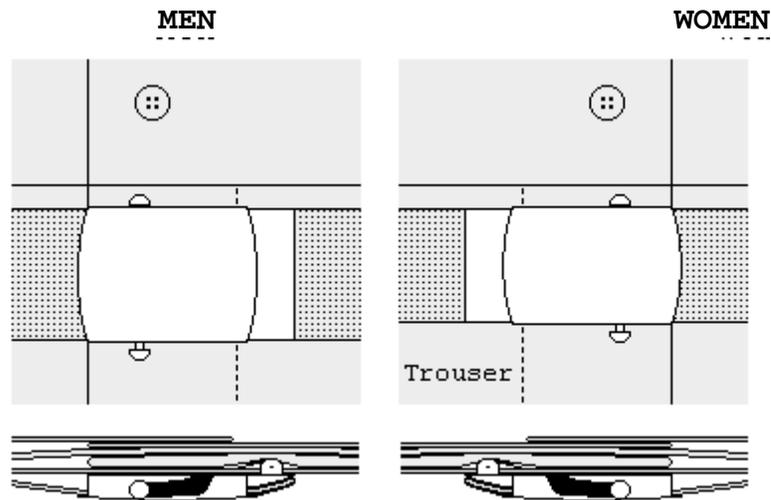

Figure 5.2

(3) Ownership Markings. Do not mark.

e. Cap, Combination

(1) Description

(a) Men. A military style cap with black visor, rigid standing front, flaring circular rim and black cap band worn with detachable khaki or white cap cover, as required. Fabric match of cap cover and uniform is required. Insignia on combination caps will be worn in accordance with article 541.a.(1)

3 Jul 14

(b) Women. A military style cap with black visor, circular brim with rigid upsweep sides and black cap band worn with detachable white or khaki cap cover, as required. Fabric match of cap cover and uniform is required. Insignia on combination caps will be worn in accordance with article 541.a.(1).

(2) Correct Wear. Wear squarely on the head, with bottom edge parallel and 1-1/2 inch above the eyebrows. The cap band with the midshipman insignia will be attached to the cover and flush with no gaps between the band and the black to white/khaki seam of the cap cover. The stitched cap band seam will align with the seam on back of the cap cover. Chin strap shall be snug and grounded to the brim. The eagles of all the retaining buttons shall be upright, with head to the top.

(3) Ownership Markings. On designated nameplate. Men mark the piece of paper provided in the vinyl slot in black ink as described in article 531 and insert this into the slot. The name is upright when the front of the frame points towards the deck. Women legibly print in black ink on the manufacturer label as described in article 531.

f. Cap, Eight Point

(1) Description. The eight pointed cap has a two piece lined crown shaped with eight evenly spaced darts, ventilation eyelets, lined outside band and self-fabric sweatband and a flexible, quilted hinge type visor.

(2) Correct Wear. The cap will be worn squarely on the head so that the visor is on a line and just above the level of the eyes. Cap insignia will be worn in accordance with article 541.a.(2).

(3) Ownership Markings. Legibly print in black ink on the manufacturer label as described in article 531.

g. Coat, Service Dress Blue

(1) Description

(a) Men. A double-breasted coat made of authorized navy blue fabric with three outside pockets, one on each hip and one on left breast, and three 35-line Navy eagle gilt buttons down each forefront. The coat has a sword slit over the left hip.

3 Jul 14

(b) Women. A single-breasted coat made of authorized navy blue fabric with one left breast pocket, and four 35-line Navy eagle buttons on the left front. The coat has a sword slit over the left hip.

(2) Correct Wear. Insignia will be worn in accordance with article 541.e. Worn with all buttons buttoned. The eagle of all of the buttons shall be upright, with head to the top.

(3) Ownership Markings. Legibly print in black ink on the manufacturer label as described in article 531.

h. Coat, Service Dress White

(1) Description

(a) Men. A single-breasted, standing collar coat made of authorized plain white, lightweight fabric, two breast patch pockets with pointed button down flaps fastened by detachable 22-1/2-line Navy eagle gilt buttons, and five detachable 35-line Navy eagle gilt buttons on right front and form fitting. The coat has sword slit over left hip and loops for shoulder boards.

(b) Women. Made of authorized white, lightweight fabric in the same style as the Service Dress Blue coat.

(2) Correct Wear. Insignia will be worn in accordance with article 541.f. Wear with all buttons buttoned. For men the collar is fastened. The eagle of all buttons shall be upright, with head to the top.

(3) Ownership Markings. Do not mark.

i. Earrings, Ball, Gold and Pearl (Women)

(1) Description. All earrings (ball or pearl) must be 4mm - 6mm (approximately 1/8 inch - 1/4 inch). Ball earrings may be plain with shiny or brushed matte finish, screw-on or post type. Ball earrings will be yellow gold.

(2) Correct Wear. Only one earring may be worn per ear, centered on the earlobe. Earrings shall not be worn in the PT uniform.

j. Gloves, Black, White

3 Jul 14

(1) Description. Black gloves are made of smooth leather or smooth synthetic leather; white gloves are made of authorized fabric. Glove stitching is the same color as the basic glove material.

(2) Correct Wear. Black leather gloves are worn, never carried. White gloves (when required) may be worn or carried with uniforms. Gloves are removed to shake hands.

(3) Ownership Markings. Mark with black or white ink as applicable centered above the inner lip as described in article 531. Do not mark dress white gloves.

k. Jacket, Black

(1) Description. A black jacket, 55/45% poly/wool with a stand-up knit collar and knit cuffs and bottom. Jacket is single-breasted with a zipper front closer, two inverted slant pockets, and shoulder epaulets.

(2) Correct Wear. Worn with zipper closed at least 3/4 of the way up and zipper grounded. May be worn with liner. Wear insignia in accordance with article 541.e.

(3) Ownership Markings. Liner: Inside on the back of the lining, centered and 1 inch below the seam in white ink as described in article 531. Shell: Inside of the jacket, centered one inch below the collar seam as described in article 531. The markings should face each other with the liner installed.

l. Parka, NWU

(1) Description. The Parka is made of laminate material and has raglan style barrel sleeves with waterproof underarm ventilating pit zippers. It has a waterproof one-way front zipper concealed by a welt, a permanently attached roll up style hood design (that can be stowed in the collar). The parka also contains two upper chest pockets with concealed water resistant slide fastener openings, two lower pockets with flaps, concealed hand warmer pockets, adjustable wrist tabs, and a rank/rate insignia tab on the outside. Concealed inside the two lower pockets are adjustable waist draw cord closures with barrel locks and an inside hanger loop.

(2) Correct Wear. The Parka is only authorized as outer wear when worn with the NWU. It was designed to be worn

3 Jul 14

with or without the detachable black fleece liner. Puncturing, pinning, or sewing items to the Parka is not authorized (with the exception of the embroidered name tape above the left sleeve pocket), as this will degrade the Parka's waterproof characteristics.

(3) Ownership Markings. Legibly print in black ink on the manufacturer label as described in article 531.

m. Necktie (Necktab), Black (Women)

(1) Description. Navy blue necktie (necktab) made of authorized fabric.

(2) Correct Wear. The necktab's outer edges should be parallel to the outer edges of the collar. An equal amount of necktab should show on each side of the collar.

(3) Ownership Markings. Using white ink, place stamp up to and touching the right of the Manufacturer's Tag, as described in article 531.

n. Necktie, Black, Four-in-Hand (Men)

(1) Description. Made of authorized fabric measuring no more than 3-1/4-inches wide.

(2) Correct Wear. Wear hand tied knotted with either a four-in-hand, half Windsor or Windsor knot. Wear the top of the knot parallel to and slightly above the top of the shirt collar closure, hiding the shirt button. The bottom hangs within 1 inch of the top of the belt buckle. The tie does not cover the belt buckle. The knot should be tight and allow for either one dimple or no dimples in the tie at the knot. The short end of the tie should not be visible.

(3) Ownership Markings. Lay flat, back up, wide end to port side. Using white ink, center the marking from the top and bottom of the necktie beginning with the first letter of the last name one inch from the manufacture label, reading left to right. Mark as described in article 531.

o. Shirt, Khaki, Service

(1) Description. Made of authorized fabric, with short sleeves, two breast pockets with button flaps, and an open

3 Jul 14

collar forming a V-neck. Women's shirts button to the left and men's shirts button to the right. The shirt and trousers fabric must match.

(2) Correct Wear. Wear with all buttons buttoned.

(3) Ownership Markings. Legibly print in black ink on the manufacturer label as described in article 531.

p. Shirt, NWU

(1) Description. The NWU shirt has two outside patch pockets with top entry flaps. The left pocket of the blouse has a concealed pencil pocket. The collar is a lay down style with rounded collar points. The blouse also contains five front concealed buttons covered by a fly opening. The elbows have reinforcement patched elbow pads. Each sleeve has an angled shoulder pocket with flaps.

(2) Correct Wear. Normal wear of the NWU shirt is outside the waistband of the NWU trousers. Sleeves will be rolled when Summer Uniforms are authorized. NWU sleeves will be rolled (cuff right-side out) forming a three inch wide band covered by the cuff of the shirt (the outside digital camouflage pattern of the NWU will show). The termination point of the roll is approximately two inches above the elbow. This manner of sleeve roll presents a short sleeve appearance and facilitates expeditious unrolling and fastening during emergent situations. All closures shall be secured with sewn buttons/holes.

(3) Ownership Markings. Legibly print in black ink on the manufacturer label as described in article 531.

q. Shirt, White, Dress

(1) Description. Male shirts are made of plain white authorized fabric, with long sleeves with plain buttons, convertible or French cuffs, with epaulets, and with a single left breast pocket without pocket flap. Collar points measure no more than 3-1/4 inches with a medium spread. Female shirts are made of plain white authorized fabric, with plain buttons, short or long sleeves with plain buttons, two breast pockets with button flaps, and epaulets. Collar points measure no more than 3-1/4 inches with a medium spread.

3 Jul 14

(2) Correct Wear. Button all buttons. Wear appropriate soft shoulder boards on the epaulets.

(3) Ownership Markings. Vertically, beginning 1 inch from the bottom on the inner side of the front fold on which the buttons are sewn. Mark as described in article 531.

r. Shirt, White, Summer

(1) Description. Men's shirts are made of plain white authorized fabric, with short sleeves, two breast pockets with button flaps, shoulder board straps, and an open collar forming a V-neck. Women's shirts are made of plain white authorized fabric, with short sleeves, two breast pockets with button flaps, epaulets, and a convertible collar. Collar points measure no more than 3-1/4-inches with medium spread. Women's shirts button to the left and men's shirts button to the right.

(2) Correct Wear. Wear with all buttons buttoned. Wear appropriate hard shoulder boards on shoulder board straps.

(3) Ownership Markings. Legibly print in black ink on the manufacturer label as described in article 531.

s. Shoes, Dress(Male) and Service(Female), Black/White

(1) Description

(a) Men. Plain toed, oxford style black or white low quarter, lace shoe, made of smooth leather or synthetic leather. The heel shall be an outside heel 3/4 inch - 7/8 inch high with a flat sole.

(b) Women. Plain or moccasin stitch toed, oxford style black or white, low quarter, lace shoe, made of smooth leather or synthetic leather. The heel shall be an outside heel 5/8 inch - 1 inch high, and the sole shall be 3/16 inch - 3/8 inch thick. Wedge heels are not authorized.

(2) Correct Wear. Keep well shined and in good repair. Candidates will lace shoes from inside out through all eyelets and tie. Lace outboard over inboard with no bridges. Shoes shall be tied over the "tongue". Double knots are authorized. Excess material shall be tucked to the outboard.

3 Jul 14

(3) Ownership Markings. Initials only inside, near the top. Three initials as close as possible to the top edge and parallel to the deck on the outboard side. Use black or white ink as appropriate for best visibility.

t. Boot, Black, Leather 9"

(1) Description. Black plain steel (safety) toe smooth leather high-top safety boot with oil resistant rubber outsoles with speed-lace eyelet closures.

(2) Correct Wear. Smooth leather boots will be blackened and buffed. Lace outboard over inboard with no bridges. Boots shall be tied over the "tongue". Double knots are authorized. Excess material shall be tucked to the outboard.

(3) Ownership Markings. Initials only inside, near the top. Three initials as close as possible to the top edge and parallel to the deck on the outboard side. Use black or white ink as appropriate for best visibility.

u. Slacks, Khaki, Service (Women)

(1) Description. Made of authorized fabric with fore and aft creases, belt loops, zippered fly front closure, and two side pockets. May be straight legged or slightly flared. The shirt and slacks fabric must match.

(2) Correct Wear. Button all buttons, close all fasteners and wear a belt through all loops. Slacks shall hang approximately 2 inches from the deck at the back of the shoe.

(3) Ownership Markings. Legibly print in black ink on the manufacturer label as described in article 531.

v. Slacks, White, Summer, Belted (Women)

(1) Description. Made of authorized white fabric with fore and aft creases, belt loops, zippered fly front closure, a modesty liner which extends to the bottom of the pockets, and two side pockets. Modification of liner is prohibited.

(2) Correct Wear. Button all buttons, close all fasteners, and wear a belt through all loops. Trousers shall hang approximately 2 inches from the floor at the back of the shoe.

3 Jul 14

(3) Ownership Markings. Legibly print in black ink on the manufacturer label as described in article 531.

w. Socks, Dress/Boot (Black/White)

(1) Description. Made of undecorated, plain or ribbed knitted material. Knee length or mid-calf socks are authorized. Sock color shall match service shoes. White athletic socks may replace black socks if prescribed for medical reasons only. When prescribed, black socks will not be worn over the white socks.

(2) Correct Wear. Wear right side out. Harness-style shirt stays must be worn inside the socks.

(3) Ownership Markings. Three initials centered on the sole between the heel and the toe, parallel to the length of the sock with the heel of the sock facing right. Initials should be in the exact center (left to right and heel to toe) of foot when worn. White socks marked with black ink, black socks with white ink.

x. Sword. Reference U.S. Navy Uniform Regulations 3501.84 for complete instruction on the sword. *As a candidate officer the knot will not be used.* The sword shall have a cut and thrust blade, from 22 inches to 36 inches long, half basket hilt, and fit in a scabbard of plain black grain leather or synthetic material presenting the leather appearance. The sword and sword belt will be provided to those officer candidates needing them.

(1) Sword Belt. The traditional sword belt is made of plain black grain leather, or synthetic material presenting the same appearance, 1-3/4 inch wide, with sling straps of the same material, 3/4 inch wide. The buckle and mounting are gold plated with the buckle 2 inches in diameter.

(2) Wearing the Sword. Wear the sword belt over the NWU shirt. The NWU shirt will be squared on the back prior to donning the sword belt. While wearing the sword belt, allow both straps to hang down, free of twists. Pass the scabbard of the sword through the belt loop (with the sword handle facing forward) until the upper swivel rests above the opening, attach the smaller strap to the upper swivel then turn until handle faces aft. Finally, take the (longer) back strap and attach it to the outside of the lower swivel.

3 Jul 14

y. Tie Clasp

(1) Description. A gold plain tie clasp not more than 5/16 inch wide.

(2) Correct Wear. May be worn on the four-in-hand tie, 1 inch below the center of the tie in a horizontal position. The uniform coat should cover it.

(3) Ownership Markings. Do not mark.

z. Trousers, Blue, Dress (Men)

(1) Description. Made of plain, authorized blue fabric with fore and aft creases, belt loops, zippered fly front closure, and two side and back pockets. May be either straight legged or slightly flared. Fabric of trousers must match the Service Dress Blue Coat.

(2) Correct Wear. Button all buttons, close all fasteners and wear a belt through all loops. Trousers shall hang approximately 2 inches from the floor at the back of the shoe.

(3) Ownership Markings. Legibly print in black ink on the manufacturer label as described in article 531.

aa. Trousers, Khaki, Service (Men)

(1) Description. Made of authorized fabric with fore and aft creases, belt loops, zippered fly front closure, and two side and back pockets. May be straight legged or slightly flared. The shirt and trousers fabric must match.

(2) Correct Wear. Button all buttons, close all fasteners and wear a belt through all loops. Trousers shall hang approximately 2 inches from the floor at the back of the shoe.

(3) Ownership Markings. Legibly print in black ink on the manufacturer label as described in article 531.

bb. Trousers, NWU

(1) Description. Trousers have an elasticized waist with belt loops. The trousers have two quarter top pockets, two bellowed thigh cargo pockets, and two back hip pockets with

3 Jul 14

flaps. There is a front zippered fly closure and button closures for the waistband and back pockets. The knees and seat have reinforcement patches.

(2) Correct Wear. Trousers will be worn fastened fully on the waist with belt buckled centered over the trouser fastener. The trouser legs shall be bloused with blousing straps so the blouse covers the top three rows of boot eyelets. When authorized to wear the trousers unbloused, the trouser leg length will not extend below the bottom of the safety boot heel. Unbloused trouser will be folded neatly (inside-out) and the fold shall lay between the third and fourth eyelet of the boot (when wearing athletic shoes with the NWU trouser the fold will lay approximately where the third and fourth eyelet would be). Organization issued or personally purchased thermal underwear is authorized to be worn underneath the NWU trousers. Thermal underwear will not be visible when worn.

(3) Ownership Markings. Legibly print in black ink on the manufacturer label as described in article 531.

cc. Trousers, White (Men)

(1) Description. Made of authorized white fabric with fore and aft creases, belt loops, zippered fly front closure, and two side and back pockets. May be either straight legged or slightly flared.

(2) Correct Wear. Button all buttons, close all fasteners and wear a belt through all loops. Trousers shall hang approximately two inches from the deck at the back of the shoe.

(3) Ownership Markings. Legibly print in black ink on the manufacturer label as described in article 531.

dd. Underpants (Women)

(1) Description. White or wearer's skin tone when worn with white uniforms. Color is optional with other uniforms.

(2) Correct Wear. Wear right side out.

(3) Ownership Markings. Do not mark.

ee. Undershirt, White

3 Jul 14

(1) Description. Made of white cotton or poly/cotton with sleeves and a crew neck.

(2) Correct Wear. Wear right side out. The crew neck shall fit snugly to the neck. Undershirt sleeves shall not extend beyond the uniform shirt sleeve.

(3) Ownership Markings. On outside of the front, one inch from the bottom of the shirt and at right of the center in black ink.

ff. Undershirt, Blue

(1) Description. Navy blue, cotton, quarter-length sleeve, with an elliptical (crew-neck) collar.

(2) Correct Wear. Wear right side out, front of shirt to front of body.

(3) Ownership Markings. On the outside of the front, one inch from the bottom of the shirt and at right of the center in white ink.

gg. Undershorts (Men)

(1) Description. White boxer shorts or knitted brief style when worn with white uniforms.

(2) Correct Wear. Wear right side out.

(3) Ownership Markings. Do not mark.

hh. Slacks, Blue, Dress, Unbelted (Women)

(1) Description. Made of plain, authorized blue fabric with fore and aft creases, left side zipper, and a waistband pocket in the upper right front. Fabric of slacks must match the Service Dress Blue coat.

(2) Correct Wear. Button all buttons, close all fasteners and wear a belt through all loops. Slacks shall hang approximately two inches from the floor at the back of the shoe.

(3) Ownership Markings. Legibly print in black ink on the manufacturer label as described in article 531.

3 Jul 14

ii. Slacks, White, Dress, Unbelted (Women)

(1) Description. Made of plain, authorized white fabric with fore and aft creases, left side zipper, a waistband pocket in the upper right front and a full free-hanging liner. Fabric of slacks must match the Service Dress White coat.

(2) Correct Wear. Button all buttons, close all fasteners. Slacks shall hang approximately two inches from the floor at the back of the shoe.

(3) Ownership Markings. Legibly print in black ink on the manufacturer label as described in article 531.

jj. Straps, Blousing

(1) Description. Made of elasticize material with either a hook or Velcro fastener. Any commercial blousing strap that will support holding the trouser leg to the boot. Navy blue, black, olive green, or tan in color.

(2) Correct Wear. Place blousing strap three eyelets down from top of the boot. Tuck pant leg up under the strap to present a neat tucked in appearance.

(3) Ownership Markings. Do not mark.

kk. Cap, Garrison

(1) Description. Fore and aft cap made of same fabric and color as uniform with which worn. Optional wear of men's style garrison cap is authorized for women with corresponding uniforms.

(2) Correct Wear. Wear squarely on the head, with fore and aft crease centered vertically between the eyebrows and the lowest point approximately one inch above the eyebrows.

(3) Ownership Markings. Legibly print in black ink on the manufacturer label as described in article 531.

ll. Cap, Knit (Watch), Black

(1) Description. Made of navy blue wool, closely knitted, bell shaped, pullover style, 11 to 12 inches long, 8-1/4 inches wide at bottom, with 5/8 inch border.

3 Jul 14

(2) Correct Wear. The watch cap will be double folded approximately 2-1/2 inches - 3 inches, and worn diagonally from the base of the back of the head, across the ears and on the forehead. Rank/rate insignia is not authorized to be worn on the watch cap.

(3) Ownership Markings. Legibly print in black ink on the manufacturer label as described in article 531.

mm. Physical Training Uniform

(1) PT Shirt

(a) Description. Gold, 100% polyester with anti-microbial and moisture wicking materials and a crewneck collar. It is of loose fit design in unisex sizing. Contains the word "NAVY" in reflective 1½ " capital letters affixed to the upper left front side and upper center back of the shirt in 3" capital letters.

(b) Correct Wear. Wear right side out, front of shirt to front of body with sleeves rolled down. The PT shirt will be tucked into shorts.

(c) Ownership Markings. Lay shirt flat with the front facing up and the neck facing away from you. Fold the bottom of the shirt up approximately six inches to expose the inside of the shirt. Place stamp on the hem to the right of the center. Marking will be on the wearer's left and upside down when worn.

(2) PT Shorts

(a) Description. Navy Blue, with 100% nylon shell and 100% polyester (with moisture wicking and odor-resistant) liner. Elastic and drawstring waistband with two side pockets (one on each side) and one hidden elastic ID card pocket attached to the waistband of the inside liner. The shorts also contain the word "NAVY" in reflective 1½" capital letters affixed to the front left leg. Shorts come in various unisex sizes with either a 6" or 8" leg length.

(b) Correct Wear. Shorts will be worn fully on the waist. The length of the shorts will not extend below the top of the knee.

3 Jul 14

(c) Ownership Markings. Last name placed on inside of front left leg, one inch from the seam. Marking will be on the wearer's left and upside down when worn.

(3) Athletic Shoes

(a) Description. Low or high-cut commercial brand athletic shoe designed to support planned exercise. Shoes should be comfortable and support the planned exercise; color is optional.

(b) Correct Wear. Wear with athletic socks and close all fasteners. Lace outboard over inboard with no bridges. Shoes shall be tied over the "tongue". Double knots are authorized. Excess material shall be tucked to the outboard.

(c) Ownership Markings. Three initials centered inside the heel of the shoe. Use black or white ink as appropriate for best visibility.

(4) Athletic Socks

(a) Description. Made of undecorated, plain or ribbed, cotton, polyester, or lycra, or any combination of those knitted materials. Socks shall not extend above mid-calf. Low cut socks are not authorized. Solid white in color.

(b) Correct Wear. Wear right side out.

(c) Ownership Markings. Three initials centered on the sole between the heel and the toe, parallel to the length of the sock with the heel of the sock facing right. Initials should be in the exact center (left to right and heel to toe) of foot when worn. Marked with black ink as described in article 531.

(5) Shirt, Sweat

(a) Description. The Navy sweat shirt is navy blue, 50/50 cotton/polyester blend (hooded or crew neck), with reflective Navy lettering outlined in gold on the back and reflective Navy lettering and Navy seal outline in gold on the front.

3 Jul 14

(b) Correct Wear. The Navy sweat shirt may be optionally worn with the PTU during command directed group/unit PT and will be worn outside of the sweat pant.

(c) Ownership Markings. Marked on hood just above bottom seam and to the right of the center hood seam.

(6) Sweat Pants

(a) Description. Sweat pant is navy blue, 50/50 cotton/polyester blend, with reflective lettering vertically outlined in gold outboard on each pant leg.

(b) Correct Wear. Navy sweat pant may be optionally worn with the PTU during command directed group/unit PT and will be worn squarely on the waist with both pant legs fully extended.

(c) Ownership Markings. On the inside and back of waistband to the right of center. Marking shall be on the left and towards the wearer's back when worn. Marked with elastic band stretched fully. Name should be legible when waistband is pulled tight.

SECTION 4 - INSIGNIA

541. INSIGNIA

a. Cap Insignia

(1) Cap, Combination. Insignia on the combination caps consist of a cap device, chin strap and retaining buttons.



Figure 5.3

(a) Cap Device. The insignia is a gold, fouled anchor. The length of the anchor, including the fouling, measures 1-13/16 inches; 1-1/8 inches wide at the flukes; 1-1/8 inches wide at the stock with other dimensions proportionate. Attach the device to the felt side of the cap band mount, with the unfouled arm of the stock facing the wearer's right.



Figure 5.4

(b) Chinstrap. The chinstrap is 1/2 inch wide, faced with gold lace and fastened at each end by a 22 1/2 line, Navy eagle, and gilt button. The chinstrap will be grounded at the center of the cover bill.



Figure 5.5

(c) Retaining Buttons. The retaining buttons should be hand tight. Over tightening them will damage the cap. Buttons shall be displayed with the eagle's wings parallel to the deck.

(2) Cap, NWU. Insignia is a gold metal fouled anchor 1-1/16 inches in length with the other dimensions proportionate. The unfouled arm of the stock faces the wearer's starboard. Pin it to the front of the cap in an upright position, centered on the front of the cap with the bottom of the insignia 1-1/4 inch from top of the bill. The retaining pins (frogs) on the back of the device will be aligned perpendicular to the device. The center of the device is defined where the chain crosses behind the stock of the anchor.

(3) Cap, Garrison. Insignia is a gold metal fouled anchor 1-1/16 inches in length with the other dimensions proportionate. The unfouled arm of the stock faces front. Pin it to the left side of the cap as worn, 2 inches from the front and 1-1/2 inch from the bottom to the center of the device. The retaining pins (frogs) on the back of the device will be aligned perpendicular to the device. The center of the device is defined where the fouled line crosses behind the stock of the anchor.

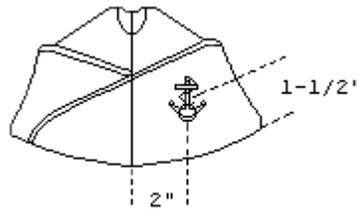

Figure 5.6

b. Name/U.S. NAVY Service Tapes

(1) Name tag. Center name tag 1/4-inch above the right breast pocket. On uniforms without a right breast pocket, place nametags on the right front in a position corresponding to ribbons on the left.

(2) Tape

(a) When wearing NWU's candidates will wear 1/2 inch colored tape on the U.S. Navy service tape in the manner described below.

(b) When wearing plastic nametags, the nametag will have a 1/2 inch colored tape grounded to the outboard and/or inboard edge of the nametag. For candidates whose names do not allow for 1/2 inch of tape, ground the tape to the first and/or last letters of the name in addition to the edge of the nametag. Candidate Officers who are restricted/conduct deficient and/or LLD/SIQ will wear the applicable colored taped over the white tape.

1 Restricted/Conduct Deficient. Yellow tape - outboard edge.

2 LLD/SIQ. Red tape - inboard edge.

3 Candidate Officer. White tape - inboard and outboard edges.

c. Shirt Collar Insignia

(1) General. Shirt collar insignia consists of gold fouled anchor, or bar devices worn on the collar tips of the NWU and khaki shirts. The retaining pins (frogs) of the collar devices will be aligned perpendicular to the device.

(2) Anchor Insignia

(a) General. A gold metal fouled anchor, 5/8 inch (right and left) worn during the Officer Candidate phase of training. The center of the device is defined where the fouled line crosses the anchor stock.



Right Left

Figure 5.7

(b) Insignia Designation

1 Indoctrination Candidate. No insignia.

2 Officer Candidate, Post RLP reinspect to Sixth Week PI. One anchor on right collar.

3 Officer Candidate, Post Sixth Week PI. One anchor on each collar and one anchor on the NWU cap.

(3) Bar Insignia

(a) General. Consists of gold metal bars worn during the Candidate Officer phase to indicate rank.

(b) Insignia Designation

1 Candidate Captain. Wear six bars.

2 Candidate Commander. Wear five bars.

3 Candidate Lieutenant Commander. Wear four bars.

4 Candidate Lieutenant. Wear three bars.

5 Candidate Lieutenant (junior grade). Wear two bars.

6 Candidate Ensign. Wear one bar.

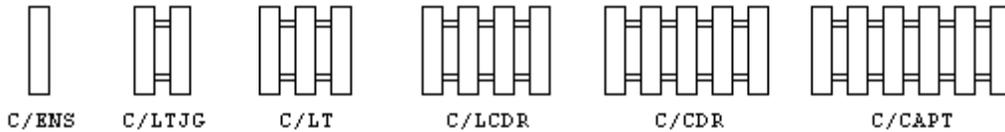

Figure 5.8

(4) Manner of Wear

(a) NWU & Service Khaki Shirt. Candidates shall wear the center of the insignia 1 inch from the inboard and outboard edges of the collar and position the vertical axis of the insignia along an imaginary line bisecting the angle of the collar point. A Candidate Captain shall wear the insignia such that the lower corners of the device are 1/4-inch from the inboard and outboard collar edges and position the vertical axis of the insignia along an imaginary line bisecting the angle of the collar point.

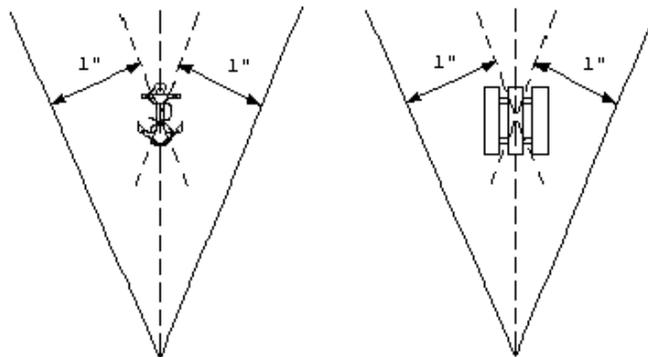

Figure 5.9

NOTE: After completing the Capstone Event candidates will wear an insignia device designating their rank on the right collar and an anchor on the left collar.

d. Shoulder Boards

(1) Officer Candidates/Candidate Officers. A single five point gold star 2 inches from the squared end of the shoulder board designates Officer Candidates. Hard shoulder boards are worn on the shoulders of Summer White shirts and white coats (men).



Figure 5.10

e. Service Dress Blue Insignia

(1) Anchor Insignia. A plain gold anchor 1-7/16 inches long, the stock, 3/4 inch wide, and the flukes 1-1/17 inches wide. The stock inclines at an angle of 8 degrees from the horizontal (right and left). Pin one on each collar tip of the coat so the anchor's crown is 1/2 inch above the notch in the lapel and the center line of the shank is parallel to and approximately 3/4 inch from the collar's outboard edge. The lower end of the stock is outboard and the stock approximately horizontal. The retaining pins (frogs) of the anchor insignia will be aligned perpendicular to the device.

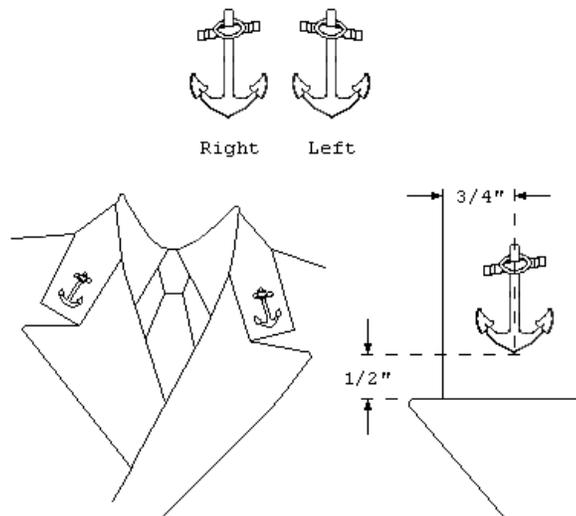

Figure 5.11

f. Service Dress White Insignia

(1) Men. Shoulder boards will be worn in accordance with article 541.e.

(2) Women. Worn in accordance with article 541.e.(1).

3 Jul 14

g. Black Jacket and All Weather Blue Coat Insignia. Candidate Officers will wear the appropriate rank insignia centered on the shoulder straps of the black jacket and all weather blue coat with the outer edge of the last bar 3/4 inch from the squared end of the shoulder strap. NOTE: No Candidate Officer Rank Insignia will be affixed to the NWU Parka, as damage may occur to the Parka.



Figure 5.12

h. Warfare, Qualification Insignia, Identification Badges, and Awards

(1) Warfare and Qualification Insignia. On all uniforms the warfare and qualification insignia are worn in a primary position, or a primary and secondary position, if a secondary device is earned. The primary position is centered on the left breast pocket with the bottom of the device 1/4-inch above the top row of ribbons or medals. Without ribbons or medals, the device is worn centered on the left breast pocket with the bottom of the device 1/4-inch above the top of the pocket. The secondary award, if earned, is centered with the top of the device 1/4-inch below the top of the left breast pocket, with ribbons. If worn with medals, the secondary award is worn centered with the top of the device 1/4-inch below the lowest row of medals. See Uniform Regulations for further guidance.

(2) Identification Badges. Not authorized at OCS.

(3) Awards

(a) Precedence of Awards. In accordance with Uniform Regulations.

(b) Ribbons. Ribbons are worn on the Summer White, Service Khaki, Service Dress Blue, and Service Dress White uniforms. Wear up to three ribbons in a single row. When more than three ribbons are authorized, wear them in horizontal rows of three each. If ribbons are not in multiples of three,

3 Jul 14

the top row contains the lesser number, and the center of this row sits over the center of the row below it. Wear ribbons without spaces between ribbons or rows of ribbons. Wear ribbons with the lower edge of the bottom row centered 1/4-inch above the left breast pocket.

(c) Full Size Medals with Ribbons. Full size medals and ribbons that do not have an associated medal are worn with the Full Dress White and Full Dress Blue uniforms. Wear the bottom row of medals on the left in accordance with the guidance below. A maximum of three medals may be worn side by side in a single row with no overlap. Four or five medals must overlap on a single row. Any additional rows of medals are worn parallel above the lower row in a manner that causes the upper row of medals to cover the suspension ribbons of the lower row. Ribbons that do not have an associated medal are worn on the right, in order of precedence from top to bottom, inboard to outboard. The ribbons are worn in accordance with the guidance below.

1 Dress White Coat and Dress Blue Coat (Men). Wear the suspension bar of the lowest row of medals parallel to the deck with the outboard edge of the suspension bar 1/4-inch above the left breast pocket. Wear the ribbons on the right side with the lowest row of ribbons at the same level as the suspension bar of the lowest row of medals and parallel to the deck.

2 Dress White Coat and Dress Blue Coat (Women). Wear the suspension bar of the lowest row of medals centered and 1/4-inch above the left breast pocket. Wear ribbons centered 1/4-inch above the right breast pocket.

(d) Miniature Medals. Miniature medals are worn with the Dinner Dress Blue and Dinner Dress White uniforms. Ribbons that do not have an associated medal are not worn with Dinner Dress uniforms. Wear up to five miniature medals in a row with no overlap. Six or more medals follow the arrangement in Uniform Regulations.

(e) Attachments. Wear attachments in accordance with the guidance of Uniform Regulations.

(4) Awards and Warfare Devices from Prior and Other Services. Uniform Regulations designate the authorized awards and warfare devices that can be worn on Navy Uniforms. Awards received for service performed while attached to units of the Army, Air Force, Marine Corps, and Coast Guard, which are not

3 Jul 14

listed in the awards section of Uniform Regulations but which are equivalent to Navy awards, may be worn in the order specified by the respective military service subject to the additional restrictions noted in Uniform Regulations. Only the warfare devices listed in Uniform Regulations may be worn on Navy uniforms. Consult the class team for further guidance.

SECTION 5 - GEAR

551. Unsecured Threads. All unsecured threads will be removed from all uniforms, physical training gear, and miscellaneous gear.

552. Miscellaneous Gear

a. Book Bag. The book bag will be marked with an ownership marking index card centered on top of the book bag lid flap.

b. Canteen. The canteen will be marked with an ownership marking index card centered on the convex canteen surface.

c. Laundry Bag. Mark flat and unfolded with the open end at the twelve o'clock position. Mark the center of the bag on both sides in black ink, parallel to the open end, with the letter tops pointing toward the open end.

d. Rifle

(1) Ownership Markings. Candidates will be instructed on the proper location of the ownership marking index card.

(2) Storage. The rifle shall be secured in the wall locker.

e. Ruler. Last name and initials, centered from the top to bottom and left to right, on the back of the ruler in black ink.

f. Shower Shoes. Place shower shoes flat with toes to port and mark two inches in from the heel, centered from the top to bottom of the shoe in black ink.

g. Towel. Mark at both ends on the side without the folded seam, centered and parallel to the end edges on the smooth band. The base of the letters shall point toward the

3 Jul 14

ends of the towel with the name centered widthwise and top to bottom on the smooth band in black ink.

h. Washcloth. Name stenciled widthwise in black ink on the smooth band nearest the bottom of the washcloth. The washcloth is marked only once. In the absence of a smooth band, the washcloth is not marked.

3 Jul 14

APPENDIX A**ACRONYMS and GLOSSARY**

ACRONYMS

BOQ	Bachelor Officer Quarters
BZ	Bravo Zulu - a job well done
BUPERS	Bureau of Naval Personnel
CDI	Chief Drill Instructor
CDO	Command Duty Officer
CO	Commanding Officer
CPO	Chief Petty Officer
CRB	Conduct Review Board
DI	Drill Instructor
DOCS	Director, Officer Candidate School
DOR	Drop on Request
DPOCS	Deputy, Officer Candidate School
EI	Extra Instruction
EMI	Extra Military Instruction
FOD	Foreign Object Damage
FSO	Flight Surgeon's Office
IAW	In Accordance With
IC	Indoctrination Candidate
IST	Initial Strength Test
LCO	Lead Class Officer
LCPO	Leading Chief Petty Officer
MCPO	Master Chief Petty Officer
MTT	Military Training Test
NAMI	Naval Aerospace Medical Institute
NAVHOSP	Navy Hospital
NETC	Naval Education and Training Command
NHCNE	Naval Health Clinic New England
NSTC	Naval Service Training Command
NCOIC	Non-Commissioned Officer In Charge
NPQ	Not Physically Qualified
NWU	Navy Working Uniform
OC	Officer Candidate
OCS	Officer Candidate School
OCSOOD	Officer Candidate School Officer of the Deck
OCR	Officer Candidate Regulations
OIC	Officer-in-Charge
OLQ	Officer-Like-Qualities
OPI	Officer Personnel Inspection
OTCN	Officer Training Command Newport
PI	Personnel Inspection
POD	Plan of the Day
PRB	Progress Review Board

PSD	Personnel Support Detachment
PT	Physical Training
RDC	Recruit Division Commander
RLP	Room, Locker and Personnel Inspection
RPT	Reinforcement Physical Training
SCPO	Senior Chief Petty Officer
SOP	Standard Operating Procedures
TTO	Training Time Out
UA	Unauthorized Absence
UCMJ	Uniform Code of Military Justice
XO	Executive Officer
IMC	Public Address Announcement System

GLOSSARY

Adrift	Loose from moorings and out of control (applied to anything lost, out of hand or left lying about (i.e. Gear Adrift)).
Aft	Facing the rear or stern of a ship or boat.
All Hands	The entire command's company, both officer and enlisted.
Aweigh	No longer touching the bottom.
Aye-Aye	Reply to an order or command meaning, "I understand and will obey."
Ballistic	Loud, clear, and forceful voice
Bitter End	The free end of a chain or line.
Bow	The front or forward end of a ship or boat.
Bracing	Standing at attention, heels and body 4 inches from the bulkhead.
Brightwork	Brass or shiny metal to be kept polished.
Bulkhead	A vertical partition in a ship; a wall.
Carry On	Original Navy meaning was to add on maximum sail. Now it is an order to resume previous activity after an interruption.
Chit	A form of written correspondence documenting a request, voucher, or message. Common types of

3 Jul 14

chits are special request, light duty, med down, and report chits.

Chow Hall Place to eat; Galley or Mess Decks.

Class Team Class Officer, Class Chief Petty Officer, and Class Drill Instructor.

Compartment Enclosed space bounded by bulkheads; a room.

Colors The national ensign, or the ceremony of raising or lowering the ensign.

Cover Headdress, hat or cap.

Covered Wearing headdress.

Deck Horizontal planking or plating that separates a ship into layers; the floor.

Door Vertical opening in compartment or bulkhead.

Ensign The national flag or the lowest grade of commissioned officer.

Field Day A time set for general cleaning usually in preparation for an inspection.

Forward Facing the bow of a ship.

Fraternizing Socializing between senior and junior or senior and subordinate or instructor and student personnel; becoming too familiar to maintain the necessary professional relationship required for good order and discipline.

Garage Storage compartment on top of the wall locker.

Gear Locker A locker or compartment under the control of the Master-at Arms used to stow gear found adrift and deserter's effects. At OCS, personal gear stowage.

Gig Line A straight, vertical line formed by the outer shirt edge, the belt buckle and trouser zipper.

Grounded A grounded item is touching or blocked by another surface. All items in an Officer Candidate's room, unless otherwise directed,

3 Jul 14

are to be grounded. For example: The chair shall be grounded to the desk.

Hatch A square or rectangular access in a deck or overhead.

Haze To discipline or harass by means of horseplay, practical jokes, humiliating/painful ordeals, or personal servitude. See Section 127.

Head A bathroom.

Indoc A candidate in the Indoctrination phase of training who has not yet completed Outpost.

Ladder A flight of stairs or staircase.

Leave Authorized vacation

Liberty Permission to leave the base, usually for not more than 48 hours.

May In orders and regulations, it means the item is optional.

Mess A meal, the place where meals are eaten, or a group who take meals together (as the officer's mess).

Outboard Away from the centerline.

Overhead The underside of a deck forms the overhead of the compartment below; the ceiling or roof.

Passageway A corridor used for interior horizontal movement aboard ship; a hall. Also called a P-way.

Phantom Gear Any items hidden for purposes of avoiding display during inspection.

Pink Sheet The report sheet that records a candidate's failure of an OCS evolution.

Pipe The act of sounding a particular call on the boatswain's pipe.

Port To the left of the centerline when facing forward; left.

3 Jul 14

Porthole	Circular access through bulkhead to the exterior of the ship; a window.
Quarters	Assembling of all hands for muster, instruction and inspection.
Quarterdeck	That part of the main deck set aside for honors and ceremonies.
Quartermaster	A rating in the Navy referring to the enlisted assistant to the navigator. At OCS, the protective coating on all brass.
Rack	Bunk or bed.
Rate	Identifies the level of enlisted personnel rating; pay grade.
Rating	A Navy job or duty classification requiring certain skills and aptitudes.
Reefer	A double-breasted, hip length coat of dark blue wool with a convertible collar and two loops on each shoulder for hard shoulder boards.
Restricted	A status that an individual candidate obtains based on poor performance.
Reveille	Wake up, start of a new day.
Room Captain	Person who occupies rack in rear starboard corner of room, door being forward.
Scuttlebutt	Originally the ship's water barrel (called a butt) which was tapped (scuttled) by inserting a spigot. Now a water fountain, or any rumor.
Secure	To make fast; with regard to spaces, seal and lock; with regard to personnel, to cease their duties; free for liberty.
Shall	In orders and regulations, it means the item is mandatory.
Shipshape	Neat, clean, taut, orderly; well organized, according to regulation.
Sickbay	Hospital or clinic.
Space	A room or compartment; an open area.

3 Jul 14

Starboard	To the right of the centerline when facing forward; right.
Stern	Refers to the rear or aft end of a ship or boat.
Stow	To store or pack articles or cargo in a space.
Swab	Mop.
Sweepers	Cleaning of designated common spaces.
Taps	Bugle call sounded at the end of the day, 2200 hours.
Tattoo	The call made five minutes before Taps.
Threads	An unsecured thread or dangling loose end of a line or piece of clothing.
Topside	Deck exposed to the weather.
Trice Up	To secure bunks by hauling them up and hanging them off (securing them) on their safety bar.
Turn To	Start work.
Two Blocked	Hoisted all the way up. At OCS, ensuring the top button of the shirt shall not be seen behind tie knot.
Very Well	Response by a senior to a report by a junior.
Watch	One of the periods (usually four hours) in to which a day is divided, or a particular duty.
Wardroom	Officers' messing compartment; also referred to as the Officers' Mess.

3 Jul 14

APPENDIX B**REQUIRED KNOWLEDGE FOR INSPECTIONS**The Oath of Office

I, _____, having been appointed an Ensign in the United States Navy, do hereby accept such appointment and do solemnly swear that I will Support and Defend the Constitution of the United States against all enemies, foreign and domestic, that I will bear true faith and allegiance to the same; that I take this obligation freely, without any mental reservation or purpose of evasion, and that I will well and faithfully discharge the duties of the office on which I am about to enter. So help me God.

The Pledge of Allegiance

I pledge allegiance to the flag of the United States of America, and to the Republic for which it stands, one nation, under God, indivisible, with liberty and justice for all.

The Sailor's Creed

I am a United States Sailor.

I will support and defend the Constitution of the United States of America and I will obey the orders of those appointed over me.

I represent the fighting spirit of the Navy and those who have gone before me to defend freedom and democracy around the world.

I proudly serve my country's Navy combat team with honor, courage and commitment.

I am committed to excellence and the fair treatment of all.

SONGS

Star Spangled Banner

(1) Oh! Say, can you see,
By the dawn's early light,
What so proudly we hailed
At the twilight's last gleaming,

(2) Whose broad Stripes and bright Stars,
Through the perilous fight,
O'er the ramparts we watched
Were so gallantly streaming?

(3) And the rocket's red glare,
The bombs bursting in air!
Gave proof through the night
That our Flag was still there.

(4) Oh! Say, does that
Star Spangled Banner yet wave,
O'er the land of the free,
And the home of the brave?

Anchors Aweigh

(1) Stand Navy out to sea, Fight our Battle Cry;
We'll never change our course, So vicious foes steer shy-y-y-y.
Roll out the TNT, Anchors Aweigh. Sail on to Victory
And sink their bones to Davy Jones, Hooray!

(2) Anchors Aweigh, my boys, Anchors Aweigh.
Farewell to foreign shores, we sail at break of day-ay-ay-ay.
Through our last night ashore, drink to the foam,
Until we meet once more, Here's wishing you a happy voyage home.

(3) Blue of the Mighty Deep; Gold of God's great sun
Let these colors be till all of time be done, done, done, done.
On seven seas we learn Navy's stern call:
Faith, Courage, Service true, with Honor, Over Honor, Over All.

3 Jul 14

The Marines' Hymn

(1) From the Halls of Montezuma,
To the shores of Tripoli,
We fight our country's battles,
In the air, on land, and sea,
First to fight for right and freedom
And to keep our honor clean,
We are proud to claim the title
Of United States Marine.

(2) Our flag's unfurled to every breeze,
From dawn to setting sun,
We have fought in every clime and place
Where we could take a gun;
In the snow of far off northern lands,
And in sunny tropic scenes,
You will find us always on the job-
The United States Marines.

(3) Here's health to you and to our Corps,
Which we are proud to serve;
In many a strife we've fought for life,
And never lost our nerve.
If the Army and the Navy
Ever look on Heaven's scenes,
They will find the streets are guarded
By United States Marines.

3 Jul 14

CHAIN OF COMMAND

Sir/Ma'am, the _____ person in this indoctrination/officer candidate's chain of command is the

1. Section Leader: _____
2. Class Chief Petty Officer and Class Drill Instructor: _____

3. Class Officer: _____
4. Officer Candidate School Lead Class Officer: _____
5. Deputy Director, Officer Candidate School: _____
6. Director, Officer Candidate School: _____
7. Executive Officer, Officer Training Command Newport: _____
8. Commanding Officer, Officer Training Command Newport: _____
9. Commander, Naval Service Training Command: _____
10. Commander, Naval Education and Training Command: _____
11. Chief of Naval Personnel: _____
12. Chief of Naval Operations: _____
13. Secretary of the Navy: _____
14. Secretary of Defense: _____
15. President of the United States: _____

3 Jul 14

CODE OF CONDUCT

Sir/Ma'am, the _____ article of the code of conduct is

1. I am an American, fighting in the forces which guard my country and our way of life. I am prepared to give my life in their defense.
2. I will never surrender of my own free will. If in command, I will never surrender the members of my command while they still have the means to resist.
3. If I am captured, I will continue to resist by all means available. I will make every effort to escape and aid others to escape. I will accept neither parole nor special favors from the enemy.
4. If I become a prisoner of war, I will keep faith with my fellow prisoners. I will give no information or take part in any action which might be harmful to my comrades. If I am senior, I will take command. If not, I will obey the lawful orders of those appointed over me and will back them up in every way.
5. When questioned, should I become a prisoner of war, I am required to give name, rank, service number and date of birth. I will evade answering further questions to the utmost of my ability. I will make no oral or written statements disloyal to my country and its allies or harmful to their cause.
6. I will never forget that I am an American, fighting for freedom, responsible for my actions, and dedicated to the principles which made my country free. I will trust in my God and in the United States of America.

Ref: Executive Order 10631

GENERAL ORDERS OF A SENTRY

Sir/Ma'am, the _____ general order of a sentry is to

1. Take charge of this post and all government property in view.
2. Walk my post in a military manner, keeping always on the alert and observing everything that takes place within sight or hearing.
3. Report all violations of orders I am instructed to enforce.
4. Repeat all calls from any post more distant from the guardhouse (quarterdeck) than my own.
5. Quit my post only when properly relieved.
6. Receive, obey, and pass on to the sentry who relieves me all orders from the commanding officer, command duty officer, officer of the deck, and officers and petty officers of the watch only.
7. Talk to no one except in the line of duty.
8. Give the alarm in case of fire or disorder.
9. Call the OOD in any case not covered by instruction.
10. Salute all officers and all colors and standards not cased.
11. Be especially watchful at night and during the time for challenging, challenge all persons on or near my post, and allow no one to pass without proper authority.

Ref: OPNAVINST 3120.32D

OFFICER RANK STRUCTURE

Navy Officer Rank Structure

Rank		Collar Device	Shoulder Board	Sleeve Insignia
W-2	Chief Warrant Officer Two (CW02)	 <p>Gold Bar with three blue breaks</p>	 <p>One gold 1/2-inch stripe with three blue breaks outboard a specialty insignia</p>	 <p>One gold 1/2-inch stripe with three blue breaks below a specialty insignia</p>
W-3	Chief Warrant Officer Three (CW03)	 <p>Silver Bar with two blue breaks</p>	 <p>One gold 1/2-inch stripe with two blue breaks outboard a specialty insignia</p>	 <p>One gold 1/2-inch stripe with two blue breaks below a specialty insignia</p>
W-4	Chief Warrant Officer Four (CW04)	 <p>Silver Bar with three blue breaks</p>	 <p>One gold 1/2-inch stripe with one blue break outboard a specialty insignia</p>	 <p>One gold 1/2-inch stripe with one blue break below a specialty insignia</p>
W-5	Chief Warrant Officer Five (CW05)	 <p>Silver Bar one 1/8th horizontal blue line</p>	 <p>Two thin gold stripes with one blue break outboard a specialty insignia</p>	 <p>Two thin gold stripes with one blue break below a specialty insignia</p>

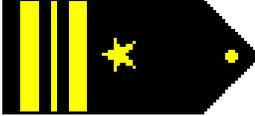
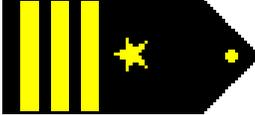
<p>O-1</p>	<p>Ensign (ENS)</p>	 <p>One gold bar</p>	 <p>One gold 1/2-inch stripe outboard of a gold five point star</p>	 <p>One gold 1/2-inch stripe below a gold five pointed star</p>
<p>O-2</p>	<p>Lieutenant Junior Grade (LTJG)</p>	 <p>One silver bar</p>	 <p>One gold 1/2-inch stripe outboard of one 1/4-inch gold stripe outboard of a five point gold star</p>	 <p>One gold 1/2-inch stripe below one 1/4-inch stripe below a gold five pointed star</p>
<p>O-3</p>	<p>Lieutenant (LT)</p>	 <p>Two silver bars</p>	 <p>Two gold 1/2-inch stripes outboard a five pointed gold star</p>	 <p>Two gold 1/2-inch stripes below a gold five pointed star</p>
<p>O-4</p>	<p>Lieutenant Commander (LCDR)</p>	 <p>Gold oak leaf</p>	 <p>One gold 1/2-inch stripe outboard one gold 1/4-inch stripe outboard one gold 1/2-inch stripe outboard one gold five pointed star</p>	 <p>One gold 1/2-inch stripe below one gold 1/4-inch stripe below one gold 1/2-inch stripe below a gold five pointed star</p>
<p>O-5</p>	<p>Commander (CDR)</p>	 <p>Silver oak leaf</p>	 <p>Three gold 1/2-inch stripes outboard a five pointed gold star</p>	 <p>Three gold 1/2-inch stripes below a gold five pointed star</p>

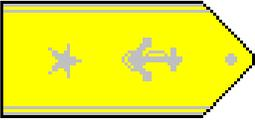
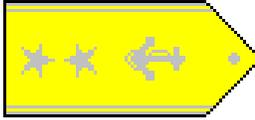
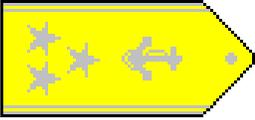
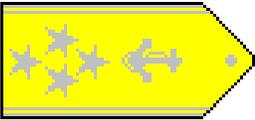
<p>O-6</p>	<p>Captain (CAPT)</p>	 <p>Silver eagle</p>	 <p>Four gold 1/2-inch stripes outboard a five pointed gold star</p>	 <p>Four gold 1/2-inch stripes below a gold five pointed star</p>
<p>O-7</p>	<p>Rear Admiral Lower Half (RDML)</p>	 <p>One silver five pointed star</p>	 <p>Gold shoulder boards with one silver five pointed star outboard a silver fouled anchor</p>	 <p>One gold 2-inch stripe below a gold five pointed star</p>
<p>O-8</p>	<p>Rear Admiral (RADM)</p>	 <p>Two silver five pointed stars</p>	 <p>Gold shoulder boards with two silver five pointed stars outboard a silver fouled anchor</p>	 <p>One gold 2-inch stripe below one gold 1/2-inch stripe below a gold five pointed star</p>
<p>O-9</p>	<p>Vice Admiral (VADM)</p>	 <p>Three silver five pointed stars</p>	 <p>Gold shoulder boards with three silver five pointed stars outboard a silver fouled anchor</p>	 <p>One gold 2-inch stripe below two gold 1/2-inch stripes below a gold five pointed star</p>
<p>O-10</p>	<p>Admiral (ADM)</p>	 <p>Four silver five pointed stars</p>	 <p>Gold shoulder boards with four silver five pointed stars outboard a silver fouled anchor</p>	 <p>One gold 2-inch stripe below three gold 1/2-inch stripes below a gold five pointed star</p>

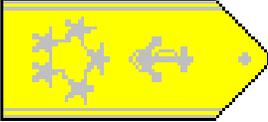
O-11	Fleet Admiral (FADM)	 <p data-bbox="488 394 662 506">Five silver five pointed stars</p>	 <p data-bbox="699 394 1052 506">Gold shoulder boards with five silver five pointed stars outboard a silver fouled anchor</p>	 <p data-bbox="1089 415 1544 527">One gold 2-inch stripe below four gold 1/2-inch stripes below a gold five pointed star</p>
------	-------------------------	---	---	---

3 Jul 14

Marine Corps Officer Rank Structure

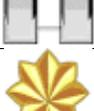
Rank		Collar Device	
W-1	Warrant Officer (W1)		Single bar device with a red background and one gold break
W-2	Chief Warrant Officer Two (CW02)		Single bar device with a red background and two gold breaks
W-3	Chief Warrant Officer Three (CW03)		Single bar device with a red background and one silver break
W-4	Chief Warrant Officer Four (CW04)		Single bar device with a red background and two silver breaks
W-5	Chief Warrant Officer (CW05)		Single silver bar device with a thin red break in the center
O-1	Second Lieutenant (2nd LT)		One gold bar
O-2	First Lieutenant (1st LT)		One silver bar
O-3	Captain (CPT)		Two silver bars
O-4	Major (MAJ)		Gold oak leaf
O-5	Lieutenant Colonel (LTCOL)		Silver oak leaf
O-6	Colonel (COL)		Silver eagle
O-7	Brigadier General (BGEN)		One silver five pointed star
O-8	Major General (MGEN)		Two silver five pointed stars
O-9	Lieutenant General (LGEN)		Three silver five pointed stars
O-10	General (GEN)		Four silver five pointed stars

ENLISTED RANK STRUCTURE

Navy Enlisted Rank Structure

Rank		Collar Device	Sleeve Insignia
E-1	Seaman Recruit (SR)	None	None
E-2	Seaman Apprentice (SA)	 Two diagonal bars	 Two diagonal stripes
E-3	Seaman (SN)	 Three diagonal bars	 Three diagonal stripes
E-4	Petty Officer Third Class (PO3)	 One eagle above one chevron	 One eagle above one chevron
E-5	Petty Officer Second Class (PO2)	 One eagle above two chevrons	 One eagle above two chevrons
E-6	Petty Officer First Class (PO1)	 One eagle over three chevrons	 One eagle above three chevrons
E-7	Chief Petty Officer (CPO)	 Gold fouled anchor with silver USN centered across the anchor	 One eagle above one rocker above three chevrons
E-8	Senior Chief Petty Officer (SCPO)	 Gold fouled anchor with silver USN centered across the anchor below one silver star	 One silver star above one eagle above one rocker above three chevrons

3 Jul 14

<p>E-9</p>	<p>Master Chief Petty Officer (MCPO)</p>	 <p>Gold fouled anchor with silver USN centered across the anchor below two silver stars</p>	 <p>Two silver stars above one eagle above one rocker above three chevrons</p>
<p>E-9</p>	<p>Master Chief Petty Officer of the Navy (MCPON)</p>	 <p>Gold fouled anchor with silver USN centered across the anchor below three silver stars</p>	 <p>Three gold stars above one eagle above one rocker above three chevrons with a gold star specialty mark</p>

Marine Corps Enlisted Rank Structure

Rank		Sleeve Insignia and Collar Devices	
E-1	Private	None	
E-2	Private First Class (PFC)		One chevron
E-3	Lance Corporal (LCpl)		One chevron over crossed rifles
E-4	Corporal (Cpl)		Two chevrons over crossed rifles
E-5	Sergeant (Sgt)		Three chevrons over crossed rifles
E-6	Staff Sergeant (SSgt)		Three chevrons over crossed rifles over one rocker
E-7	Gunnery Sergeant (GySgt)		Three chevrons over crossed rifles over two rockers
E-8	Master Sergeant (MSgt)		Three chevrons over crossed rifles over three rockers
E-8	First Sergeant (1stSgt)		Three chevrons over one diamond over three rockers
E-9	Master Gunnery Sergeant (MGySgt)		Three chevrons over a bursting bomb over four rockers
E-9	Sergeant Major (SgtMaj)		Three chevrons over one star over four rockers
E-9	Sergeant Major of the Marine Corps (SMMC)		Three chevrons over the Marine Corps emblem centered between two five pointed stars over four rockers

3 Jul 14

BREAST INSIGNIA/SLEEVE DEVICESOfficer Breast Insignia

Naval Aviator Insignia: A gold embroidered or gold metal winged pin with a fouled anchor behind a shield in the center.



Naval Flight Officer Insignia: A gold embroidered or gold metal winged pin with a set of small, crossed, fouled anchors behind a shield in the center.



Surface Warfare Insignia: A gold embroidered or gold metal pin, with the bow and superstructure of a modern naval warship superimposed on two crossed swords, on a background of ocean swells.



Submarine Warfare Insignia: A gold embroidered or gold metal pin showing the bow view of a submarine proceeding on the surface with bow planes rigged for diving flanked by dolphins in horizontal position, their heads resting on the upper edge of the bow planes.

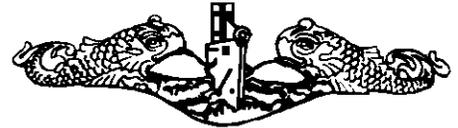

Special Warfare Insignia: A gold metal pin with an eagle holding a trident and a handgun, in front of an anchor.

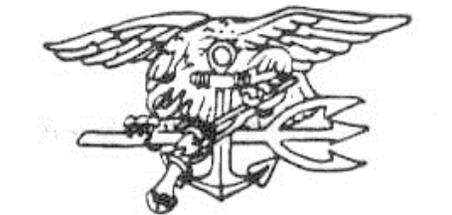

Naval Aviation Supply Insignia: A gold embroidered or gold metal winged pin with a supply corps oak leaf in the center.



Submarine Supply Insignia: A gold embroidered or gold metal pin with two dolphins facing a supply corps oak leaf in the center.



Surface Warfare Supply Insignia: A gold embroidered or gold metal pin with a supply corps oak leaf centered on the bow and superstructure of a modern naval warship superimposed on two crossed naval swords, on a background of ocean swells.



3 Jul 14

Diving Officer Insignia: A gold metal pin with two upright sea horses facing a diving helmet, and two tridents projecting upward and canted outward from the diving helmet's cover. A double carrick bend superimposed on the breast plate.

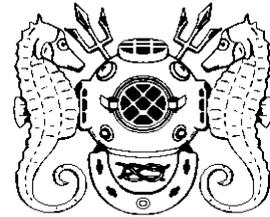

Seabee Combat Warfare Specialist Insignia: A gold metal pin with a bee on crossed sword and gun superimposed on an anchor on a background of leaves.

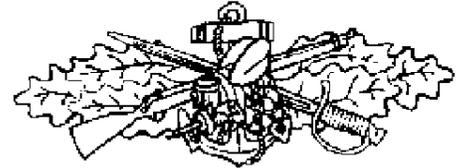

Special Operations Officer Insignia: A gold embroidered or gold metal pin, with the bow and superstructure of a modern naval warship on a background of ocean swells with an ordnance disposal bomb over crossed lightning rays on one side, and a diving helmet over two tridents on the other.

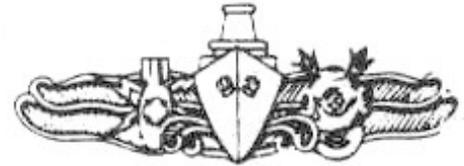

Information Dominance Insignia: A gold embroidered or gold metal pin of a globe superimposed on an anchor over a crossed sword and lightning bolt, on a background of ocean swells.

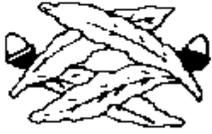

Officer Sleeve, Shoulder Board and Collar Devices

	Sleeve and Shoulder Board Devices	Collar Devices
Line and Restricted Staff	 A gold embroidered five-pointed star.	 Rank insignia are worn on both collars
Supply Corps	 A gold embroidered sprig of three oak leaves and three acorns.	  A gold metal sprig of three oak leaves and three acorns worn on the left collar. Rank insignia is worn on the right collar.
Civil Engineer Corps	 Two gold embroidered sprigs of two oak leaves and a silver acorn in each sprig.	  A gold metal pin with two sprigs of two oak leaves and a silver acorn in each sprig worn on the left collar. Rank insignia is worn on the right collar.

3 Jul 14

NAVAL MISSION

The mission of the Navy is to maintain, train and equip combat-ready Naval forces capable of winning wars, deterring aggression and maintaining freedom of the seas.

WARFARE

Levels of War

Strategic level focuses on supporting national goals. Operational level concerns forces collectively in theater.

Tactical level involves the details of individual engagements.

War at Sea

War at sea is the application of decisive offensive force to achieve control of the sea which is the first step in establishing our superiority in any region.

Littoral Warfare

Littoral warfare is warfare in that portion of the world's land masses, adjacent to the oceans within direct control of and vulnerable to the striking power of sea-based forces.

Naval Tactical Mission

Primary Warfare Areas

Strike Warfare (STW)- Any combination of naval forces that intends to inflict damage on or destroy the target objective.

Amphibious Warfare - Establishing a landing force on a hostile shore.

Mine Warfare (MIW) - The use of mines and mine countermeasures to control or deny the use of sea or harbor areas through the laying of minefields and countering enemy mine warfare through the destruction or neutralization of hostile minefields.

3 Jul 14

Air Warfare (AW) - Those actions required to destroy or reduce the enemy air and missile threat to an acceptable level.

Undersea Warfare (USW) - Those actions taken to deny the enemy effective use of his submarines and the undersea environment.

Surface Warfare (SUW) - Deny the enemy effective use of his surface warships and merchant capability.

Supporting Warfare Areas

Special Warfare - Non-conventional operations in the coastal, riverine, and maritime environments. Naval special warfare emphasizes small, flexible, mobile units operating under, on, and from the sea.

Intelligence - Assessment and management of information obtained via surveillance, reconnaissance and other means to produce timely information of potential enemies and threats.

Electronic Warfare (EW) - Ensure the effective use of the electromagnetic spectrum to friendly forces while denying its use to the enemy.

Logistics - Re-supply of combat consumables to combat forces within a theater of operations.

PHONETIC ALPHABET

Letter	Pronunciation	Letter	Pronunciation
A Alpha	AL fah	N November	no VEM ber
B Bravo	BRAH voh	O Oscar	OSS cah
C Charlie	CHAR lee	P Papa	pah PAH
D Delta	DELL tah	Q Quebec	kay BECK
E Echo	ECK oh	R Romeo	ROW me oh
F Foxtrot	FOKS trot	S Sierra	see AIR rah
G Golf	GOLF	T Tango	TANG go
H Hotel	hoh TELL	U Uniform	YOU nee form
I India	IN dee ah	V Victor	VIK tah
J Juliet	JEW lee et	W Whiskey	WISS key
K Kilo	KEY loh	X X-Ray	ECKS ray
L Lima	LEE mah	Y Yankee	YANG key
M Mike	MIKE	Z Zulu	ZOO loo

FIFTEEN LEADERSHIP TRAITS

Remember these by this mnemonic aid: JJ DID TIE BUCKLE H.

1. Judgment: The ability to weigh facts and possible solutions on which to base sound decisions.
2. Justice: Giving reward and punishment according to merits of the case in question; the ability to administer a system of rewards and punishments impartially and consistently.
3. Decisiveness: Ability to make decisions promptly and to announce them in clear, forceful manner.
4. Initiative: Taking action in the absence of orders.
5. Dependability: The certainty of proper performance of duty.
6. Tact: The ability to deal with others without creating offense.
7. Integrity: Uprightness of character and soundness of moral principles; includes the qualities of truthfulness and honesty.
8. Endurance: The mental and physical stamina measured by the ability to withstand pain, fatigue, stress and hardship.
9. Bearing: Creating a favorable impression in carriage, appearance and personal conduct at all times.
10. Unselfishness: Avoidance of providing for one's own comfort and personal advancement at the expense of others.
11. Courage: The mental quality that recognizes fear of danger or criticism, but enables a person to proceed in the face of it with calmness and firmness.
12. Knowledge: Understanding of a science or an art. The range of one's information, including professional knowledge and an understanding of your Sailors.

3 Jul 14

13. Loyalty: The quality of faithfulness to country, the Navy, the unit, to one's seniors, subordinates and peers.

14. Enthusiasm: The display of sincere interest and exuberance in the performance of duty.

15. Honor: To regard or treat with honor, esteem, or respect; to revere; to treat with deference and submission.

APPENDIX C

ADDITIONAL INFORMATION FOR CANDIDATE'S PROFESSIONAL DEVELOPMENT

C001. Air-to-Air Missiles

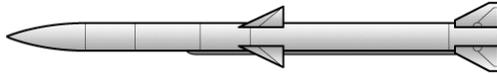

a. **Advanced Medium-Range, Air-to-Air Missile (AMRAAM) (AIM-120).** An all-weather, beyond-visual range, air-to-air missile. The missile's dependent free control allows the pilot to aim and fire multiple missiles while evading enemy fire.

- (1) Weight: 345 pounds (lb)
- (2) Length: 12 feet (ft)
- (3) Speed: Classified
- (4) Range: Classified
- (5) Warhead: Blast Fragmentation High-Explosive
- (6) Platforms: F/A-18 A-D Hornet, F-35 Lightning



b. **Sidewinder Missile (AIM-9).** The Sidewinder is a short range, supersonic, heat-seeking, air-to-air missile carried by fighter aircraft.

- (1) Weight: 188 lbs
- (2) Length: 9 ft 4 inches (in)
- (3) Speed: Classified
- (4) Range: Classified
- (5) Warhead: Annular Blast Fragmentation
- (6) Platforms: F/A-18 A-D Hornet, F/A-18 E-F Super Hornet, F-35 Lightning

C002. Cruise Missiles

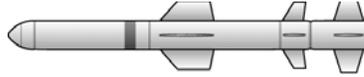

a. **Harpoon (AGM-84, RGM-84, UGM-84)**. The Harpoon is a long-range sea-skimming, anti-ship missile capable of being fired from air, ship or submarine.

- (1) Weight: 1,532 lbs
- (2) Length: 15 ft (Ship and Submarine launched)
12 ft, 7 in (Aircraft launched)
- (3) Speed: High Subsonic
- (4) Range: In excess of 67 nm
- (5) Warhead: Penetration/high-explosive blast
- (6) Platforms:
 - (a) Air (AGM-84): F/A-18, P-3C
 - (b) Ship (RGM-84): CG, DDG
 - (c) Submarine (UGM-84): SSN



b. **Tomahawk (BGM-109)**. The Tomahawk Land Attack Missile (TLAM) is an all-weather, long range, subsonic cruise missile used for land attack warfare, launched from U. S. Navy surface ships and U.S. Navy and Royal Navy submarines.

- (1) Weight: 2,900 lbs
- (2) Length: 18 ft 3 in
- (3) Speed: Subsonic
- (4) Range: Approx 900 - 1,350 nm depending on block
- (5) Warhead: Conventional High-Explosive
- (6) Platforms:
 - (a) Ship: CG, DDG
 - (b) Submarine: SSN, SSGN

C003. Surface-to-Air Missiles

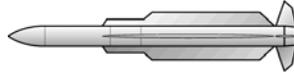

a. The **Standard Missile** Family - Medium-long range shipboard surface-to-air missile. Standard Missile 2 (SM-2) is the U.S. Navy's primary surface-to-air air defense weapon. It is an integral part of the Aegis Weapon System (AWS) aboard Ticonderoga-class cruisers and Arleigh Burke-class destroyers, and is launched from the MK 41 Vertical Launcher System (VLS). Its primary missions are fleet area air defense and ship self-defense, but it also has demonstrated an extended area air defense projection capability. The SM-2 uses tail controls and a solid fuel rocket motor for propulsion and maneuverability. All variants are guided by inertial navigation and mid-course commands from Aegis Weapon System (AWS); terminal homing is accomplished using semi-active radar (a Continuous Wave Radar system) from the ship or an Infrared (IR) sensor on the missile.

- (1) Weight: 1,558 lb
- (2) Length: 15 ft 6 in
- (3) Speed: Mach 2+
- (4) Range: 40-90 nautical miles (nm)
- (5) Warhead: Blast fragment warhead
- (6) Platforms: CG, DDG



b. **Seasparrow Missile (RIM-7)**. The Seasparrow RIM-7 Missile is a radar-guided, surface-to-air missile. Seasparrow is short-range, semi-active homing missile that makes flight corrections via radar uplinks. The missile provides reliable ship self-defense capability against a variety of air and surface threats, including high-speed, low-altitude anti-ship cruise missiles. It is widely deployed by U.S., North Atlantic Treaty Organization (NATO), and other international partner navies.

- (1) Weight: 500 lbs

- (2) Length: 12 ft
- (3) Speed: Classified
- (4) Range: Classified
- (5) Warhead: Annular Blast Fragmentation
- (6) Platforms: CVN, LHD, LHA



c. **Rolling Airframe Missile (RAM) (RIM-116).** The RIM-116 RAM is a lightweight, quick-reaction, fire-and-forget missile designed to destroy anti-ship cruise missiles and asymmetric air and surface threats.

- (1) Weight: 162 lbs
- (2) Length: 9.3 ft
- (3) Speed: Supersonic
- (4) Range: 5.6 mi
- (5) Warhead: blast fragmentation warhead
- (6) Platforms: CVN, LHA/LHD, LPD, LSD, LCS

C004. Fleet Ballistic Missiles



a. **Trident II (D-5)** - Intercontinental ballistic missiles launched from submarines. Trident II is launched by the pressure of expanding gas within the launch tube. When the missile attains sufficient distance from the submarine, the first stage motor ignites, the aerospike extends and the boost stage begins. Within about two minutes, after the third stage motor kicks in, the missile is traveling in excess of 20,000 feet (6,096 meters) per second.

(1) Weight: 130,000 lbs.

(2) Warhead: Nuclear Multiple Independently Targetable Re-entry Vehicles.

(3) Propulsion: Three-stage, solid-fuel rocket

(4) Range: Greater than 4,000 nm

(5) Platforms: SSBN

C005. Air-to-Ground Missiles

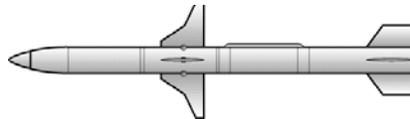

a. **HARM Missile (AGM-88)**. The AGM-88 High-Speed Anti-radiation Missile is an air-to-surface tactical missile designed to seek out and destroy enemy radar-equipped air defense systems.

(1) Length: 13 ft. 8 in.

(2) Weight: 800 lbs.

(3) Warhead: Blast Fragmentation.

(4) Propulsion: Thiokol dual-thrust, solid propellant, rocket motor.

(5) Speed: 760+ miles per hour

(6) Range: 57+ nm

(7) Platforms: EA-6B, EA-18G, F-18E/F, F-35

3 Jul 14



b. **Maverick Guided Missile (AGM-65).** The AGM-65 Maverick is an air-to-surface tactical missile designed for close air support, interdiction, and defense suppression. It is effective against a wide range of tactical targets, including armor, air defenses, ships, ground transportation, and fuel storage facilities.

- (1) Length: 98 in.
- (2) Weight: 462 - 670 lbs
- (3) Warhead: Penetrating blast fragmentation
- (4) Propulsion: Solid propellant rocket
- (5) Speed: Supersonic
- (6) Range: 17 nm
- (7) Platforms: F/A-18, P-3C

3 Jul 14

C006. Surface launched anti-submarine rocket missile:

a. **Vertical Launch Anti-Submarine Rocket Missile (ASROC) (VLA).** The Vertical Launch Anti-Submarine Rocket is a surface-ship launched anti-submarine rocket missile designed to deliver the MK 46 or the MK 54 torpedo to a water-entry point close to a targeted submarine.

- (1) Length: 16.7 ft.
- (2) Weight: 1650 lbs.
- (3) Warhead: High explosive
- (4) Propulsion: Solid propellant rocket
- (5) Range: Over 10 miles
- (6) Platform: DDG, CG

C007. Torpedoes

3 Jul 14

a. **MK 48 - Heavyweight Torpedo.** The MK 48 heavyweight torpedo is used by all classes of submarines as their anti-submarine warfare (ASW) and anti-surface warfare weapon.

- (1) Diameter: 21 in.
- (2) Weight: 3,520 lbs
- (3) Range: 5+ miles
- (4) Speed: 28+ knots (kts)
- (5) Warhead: High explosive
- (6) Depth: 1,200+ ft
- (7) Platform: SSN, SSGN, SSBN



b. **MK 46 - Torpedo.** The MK 46 torpedo is a surface ship and aircraft-launched anti-submarine weapon. It is the NATO standard light-weight torpedo and has been acquired by more than 25 countries. Various modifications, including improved acoustics, guidance and control upgrades, and countermeasure-detection capability have been introduced into the weapon.

- (1) Diameter: 12.8 in
- (2) Weight: 508 lbs
- (3) Range: 6 miles
- (4) Speed: 40+ kts
- (5) Warhead: High explosive
- (6) Depth: 1,200+ ft
- (7) Platforms: SH-60, P-3C, CG, DDG, FFG



c. **MK 50 - Torpedo.** The MK 50 torpedo is a highly capable undersea weapon for U.S. Navy surface ships and aircraft

3 Jul 14

developed to replace the MK 46 torpedo. The MK 50 is designed to counter the fast, deep-diving, double-hulled nuclear submarine threat. Relative to the MK 46, the MK50 has increased range, more sophisticated counter-countermeasure logic, and greater lethality, speed, depth, and endurance.

- (1) Diameter: 12.75 in.
- (2) Weight: 800 lbs
- (3) Speed: 40+ kts
- (4) Warhead: Conventional
- (5) Platforms: CG, DDG, P-3C, P-8A

C008. Naval Guns



a. **MK 15 - Phalanx Close-In Weapons System (CIWS).** Fast-reaction, detect-to-engage, and radar guided 20-millimeter gun weapon system. MK 15 Phalanx CIWS provides ships of the U.S. Navy with an inner layer point defense capability against Anti-Ship Missiles (ASM), aircraft, and littoral warfare threats that have penetrated other fleet defenses. Phalanx automatically detects, evaluates, tracks, engages, and performs kill assessment against ASM and high speed aircraft threats.

- (1) Rate of Fire: 3,000 - 4,500 rounds per minute
- (2) Range: 2,000 yds
- (3) Platforms: CG, CVN, DDG, FFG, LHA, LHD, LPD, LSD

3 Jul 14



b. **MK 45 - 5-inch-gun 54/62 Caliber Guns.** Fully-automatic naval gun mount employed against surface, air, and land attack (Naval Surface Fire Support - NSFS) targets.

(1) Rate of Fire: 16-20 rounds per minute

(2) Range: 13 nm for surface targets, 6 nm for air targets

(3) Platforms: CG, DDG



c. **MK 75 - 76mm/62 Caliber Gun.** Lightweight, fully automated, remote controlled, rapid-fire, 76mm gun mount. The MK 75 gun is suitable for installation on small combatants due to its light weight, and low manpower requirements.

(1) Rate of Fire: 85 rounds per minute

(2) Range: 10 nm

(3) Platforms: FFG

3 Jul 14



d. **MK 38 - 25 mm machine gun system.** The MK-38 is a 25-mm machine gun installed for ship self-defense to counter High Speed Maneuvering Surface Targets.

(1) Rate of Fire: Single shot/180 rounds per minute

(2) Range: 2,700 yds

(3) Platforms: CG, DDG, FFG, LSD, LPD, LHD, LHA, LCC,
PC

C009. Launchers

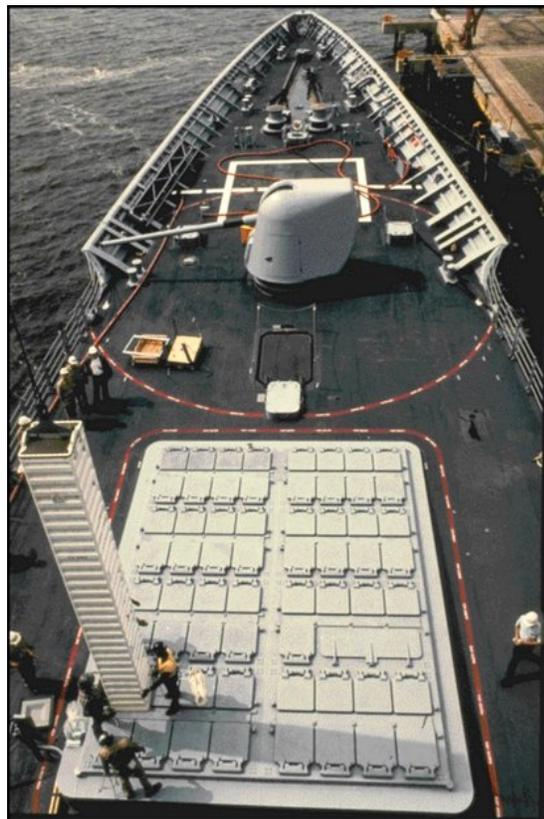
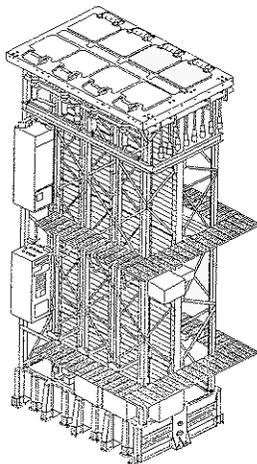

e. **MK 41 Vertical Launch System (VLS).** The MK 41 VLS is a modular, below deck missile launching system that was originally designed for the Navy's Aegis-equipped guided missile cruisers to provide air threat protection for naval battle groups. The Mk 41 VLS is a multi-missile, multi-mission launcher, capable of launching SM-2, SM-3, SM-6, Evolved Sea Sparrow Missile (ESSM), Tomahawk, and Vertical Launch Anti-Submarine Rocket (ASROC) (VLA) Missiles.

(1) Platforms: CG, DDG.

C010. Naval Aircraft



a. **F/A-18 Hornet strike fighter.** All-weather fighter and attack aircraft. The F/A-18 Hornet is the nation's first strike-fighter. It was designed for traditional strike applications such as interdiction and close air support without compromising its fighter capabilities. The F/A-18A/C Hornets are single seat variants. The F/A-18B/D Hornets are dual seat variants.

(1) Crew: 1 (A,C Models), 2(B,D Models)

(2) Length: 56 ft

(3) Wingspan: 40 ft. 5 in.

(4) Max Speed: Mach 1.75+

(5) Armament: 20mm 6-barrel gun, 17,000 lbs of bombs and missiles: Sparrow, Sidewinder, AMRAAM, Maverick and Harpoon.

3 Jul 14



b. **F/A-18 Super Hornet.** The F/A-18E/F Super Hornets are the newest and most capable aircraft in the series. The F/A-18E Super Hornet is a single seat variant. The F/A-18F Super Hornet is a dual seat variant.

(1) Crew: 1(E Model), 2(F Model)

(2) Length: 60.3 ft.

(3) Wingspan: 44.9 ft.

(4) Max Speed: Mach 1.8+

(5) Armament: 20mm 6-barrel gun, 17,000 lbs of bombs and missiles: Sparrow, Sidewinder, HARM, Maverick and Harpoon.



c. **EA-18G Growler Airborne Electronic Attack Aircraft.** Built to replace the EA-6B Prowler, the Growler is the first newly-designed electronic warfare aircraft produced in more than 35 years. The aircraft also retains all of the F/A-18E/F multi-mission capabilities with its validated design and the capability to perform a wide range of enemy defense suppression missions. The EA-18G Growler, an Airborne Electronic Attack aircraft integrates the latest electronic attack technology, including the ALQ-218 receiver, ALQ-99 jamming pods, communication countermeasures, and satellite communications.

(1) Crew: 2

(2) Length: 60.2 ft.

(3) Wingspan: 44.9 ft.

(4) Combat Range: 850+ nm

(5) Armament: Two AIM-120, two AGM-88 HARM, three ALQ-99.



d. **EA-6B Prowler electronic warfare aircraft.** The EA-6B Prowler provides an umbrella of protection for strike aircraft, ground troops and ships by jamming enemy radar, electronic data links and communications. The Prowler is a long-range, all-weather aircraft with advanced electronic countermeasures capability. Manufactured by the Northrop Grumman Systems Corporation, it is a twin-engine, mid-wing configured aircraft that has a side by-side cockpit arrangement.

(1) Crew: 4 (1 pilot, 3 Electronic Countermeasure Officers)

(2) Length: 59 ft 10 in

(3) Wingspan: 53 ft

(4) Max Speed: 500+ kts

(5) Armament: HARM, ALQ-99 Tactical Jamming System



e. **F-35 Lightning.** The F-35 Lightning II is a family of single-seat, single-engine, designed to perform ground attack, reconnaissance, and air defense missions with stealth capability. The F-35 has three main modes: the F-35A (USAF) is

3 Jul 14

a conventional takeoff and landing variant, the F-35B (USMC) is a short take-off and vertical-landing variant, and the F-35C (NAVY) is a carrier-based variant.

(1) Crew: 1

(2) Length: 51.4 ft.

(3) Wingspan: 35 ft.

(4) Max Speed: Mach 1.6+

(5) Armament: 25mm 4-barrel cannon, 18,000 lbs of bombs and missiles.



f. **E-2 Hawkeye early warning and control aircraft.** The E-2 Hawkeye is the Navy's all-weather, carrier-based tactical battle management airborne early warning, command and control aircraft. The E-2 is a twin engine, five crewmember, high-wing turboprop aircraft with a 24-foot diameter radar rotodome attached to the upper fuselage.

(1) Crew: 5 (2 pilots, 3 mission operators)

(2) Length: 57 ft 6 in

(3) Wingspan: 80 ft 7 in

(4) Max Speed: 300+ kts

(5) Armament: None



g. **P-3C Orion long range ASW aircraft.** Four-engine turboprop anti-submarine and maritime surveillance aircraft. The P-3C has advanced submarine detection sensors such as directional frequency and ranging sonobuoys and magnetic anomaly detection equipment. The avionics system is integrated by a general purpose digital computer that supports all of the tactical displays, monitors and automatically launches ordnance and provides flight information to the pilots.

- (1) Crew: 11
- (2) Length: 116.7 ft.
- (3) Wingspan: 99.6 ft.
- (4) Max Speed: 411 kts
- (5) Armament: Harpoon, Maverick, torpedoes, and mines



h. **P-8A Poseidon ASW/ASuW aircraft.** The P-8A Poseidon is a modified Boeing 737-800ERX, bringing together a highly reliable airframe and high-bypass turbo fan jet engine with a fully connected, state-of-the-art open architecture mission system. This combination, coupled with next-generation sensors, will dramatically improve anti-submarine warfare (ASW), and anti-surface warfare (ASuW) capabilities.

- (1) Crew: 9
- (2) Length: 129.5 ft.
- (3) Wingspan: 123.5 ft.
- (4) Max Speed: 490 kts
- (5) Armament: Joint missiles, torpedoes, and mines



i. **C-2A Greyhound logistics aircraft.** A high wing, twin-engine monoplane cargo aircraft, designed to land on aircraft carriers. The C-2A Greyhound provides critical logistics support to Carrier Strike Groups. Its primary mission is the transport of high-priority cargo, mail and passengers between carriers and shore bases.

- (1) Crew: 4
- (2) Length: 56 ft. 10 in
- (3) Wingspan: 80 ft. 7 in.
- (4) Max Speed: 260 kts
- (5) Armament: None



j. **C-130T Hercules logistics aircraft.** The C-130 Hercules, a four-engine turboprop aircraft, is the workhorse of the military services. Capable of landing and taking off from short, rough dirt runways, it is a people and cargo hauler and is used for rapid logistical support.

- (1) Crew: 5
- (2) Length: 97 ft, 9 in
- (3) Wingspan: 132 ft, 7 in
- (4) Max Speed: 374 mph
- (5) Armament: None



k. **MH-60 Seahawk Helicopter.** It is used for anti-submarine warfare, search and rescue, drug interdiction, anti-ship warfare, cargo lift, and special operations. The Navy's MH-60R Seahawk is an airborne platform based aboard carriers, cruisers, destroyers, and frigates and deploys sonobuoys (sonic detectors), dipping sonar, and torpedoes in an anti-submarine role. They also extend the range of the ship's radar, and anti-surface capabilities. The MH-60S, also aboard carriers and amphibious assault ships, is used for search and rescue (SAR) missions, combat search and rescue (CSAR), and Naval Special Warfare (NSW).

- (1) Crew: 3-4
- (2) Length: 64 ft, 10 in (rotors and tail folded)
- (3) Max Speed: 180 kts

3 Jul 14

(4) Armament: MK46/50 torpedoes, .50 caliber and M240 machine guns, air-to-surface missiles and various.



1. **MH-53E Sea Dragon Helicopter.** The MH-53E is used primarily for Airborne Mine Countermeasures with secondary missions of vertical shipboard delivery and assault support. The MH-53 can operate from carriers and other warships and is capable of towing a variety of mine hunting/sweeping countermeasures systems, including the Mk 105 magnetic minesweeping sled, the AQS-14A side-scan sonar, and the Mk 103 mechanical minesweeping system. When performing the assault support mission, the MH-53E can be fitted with the GAU-21 .50-cal. machine gun ramp-mounted weapon system.

(1) Crew: 3

(2) Length: 99 ft

(3) Max Speed: 150+ kts

(4) Armament: GAU-21, 50 cal. Machine gun.

C011. Ships of the United States Fleet



3 Jul 14

a. **Nuclear Aircraft Carriers (CVN).** Aircraft carriers are the centerpiece of America's Naval forces. On any given day, aircraft carriers exercise the Navy core capabilities of power projection, forward presence, humanitarian assistance, deterrence, sea control and maritime security.

(1) NIMITZ Class

(a) Length: 1,092 ft

(b) Beam: 134 ft

(c) Speed: 30+ kts

(d) Crew: Ship's Company: 3,000-3,200, air wing: 1,500, other: 500.

(e) Armament: Multiple NATO Sea Sparrow, Phalanx CIWS, and RAM mounts.

(f) Propulsion: Two nuclear reactors, four shafts.

(g) Aircraft: Approximately 60+

(2) FORD Class

(a) Length: 1,092 ft

(b) Beam: 134 ft

(c) Speed: 30+ kts

(d) Crew: 4,539 (ship, air wing and staff).

(e) Armament: Evolved Sea Sparrow Missile, Rolling Airframe Missile and CIWS.

(f) Propulsion: Two nuclear reactors, four shafts.

(g) Aircraft: Approximately 75+

3 Jul 14



b. **Guided Missile Cruisers (CG).** Large combat vessel with multiple target response capability. Modern U.S. Navy guided missile cruisers perform primarily in a Battle Force role. These ships are multi-mission [Air Warfare (AW), Undersea Warfare (USW), NSFS and Surface Warfare (SUW)] surface combatants capable of supporting carrier battle groups, amphibious forces, or of operating independently and as flagships of surface action groups. Cruisers are equipped with Tomahawk cruise missiles giving them additional long range Strike Warfare capability. Some Aegis Cruisers have been outfitted with a Ballistic Missile Defense capability. Primary mission is AW.

(1) Class: TICONDEROGA

(2) Length: 567 ft

(3) Beam: 55 ft

(4) Speed: 30+ kts

(5) Crew: 30 officers, 300 enlisted

(6) Armament: SM-2, Tomahawk Cruise Missile, Mk-46 Torpedoes, Two MK 45 5-inch/54 caliber lightweight guns, two MK 15 Phalanx CIWS, small arms, ASROC, Harpoon

(7) Propulsion: 4 General Electric LM 2500 gas turbine engines; 2 shafts, 80,000 shaft horsepower total.

(8) Aircraft: 2 MH-60 Seahawks

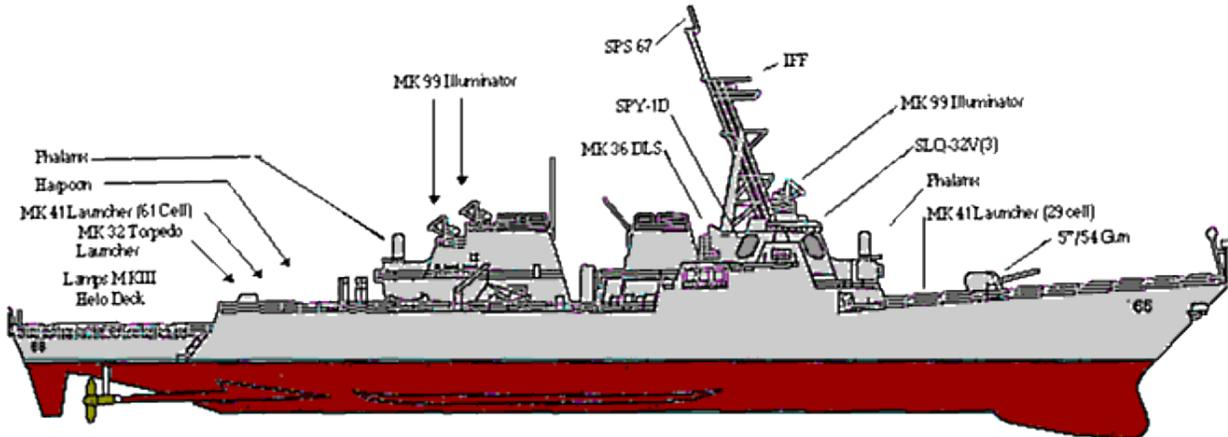

c. **Guided Missile Destroyers (DDG).** Destroyers are warships that provide multi-mission offensive and defensive capabilities. Destroyers can operate independently or as part of carrier strike groups, surface action groups, amphibious ready groups, and underway replenishment groups. Guided missile destroyers are multi-mission (Anti-Air Warfare (AAW), Anti-Submarine Warfare (ASW), and Surface Warfare (SUW)) surface combatants. The destroyer's armament has greatly expanded the role of the ship in strike warfare using the Mk 41 Vertical Launch System (VLS).

- (1) Class: ARLEIGH BURKE
- (2) Length: 505 ft
- (3) Beam: 59 ft
- (4) Speed: 30+ kts
- (5) Crew: 23 officers, 276 enlisted

(6) Armament: SM-2, Harpoon Cruise Missile, Tomahawk Cruise Missile, Mk-46 Torpedoes, One MK 45 5-inch/54 caliber lightweight guns, two MK 15 Phalanx CIWS, small arms, vertical launch ASROC.

(7) Propulsion: Four General Electric LM 2500-30 gas turbines; two shafts, 100,000 total shaft horsepower.

- (8) Aircraft: 1-2 MH-60 Seahawks



d. **Guided Missile Frigate (FFG).** Fulfill a Protection of Shipping (POS) mission as ASW combatants for amphibious expeditionary forces, underway replenishment groups and merchant convoys. Designed as cost efficient surface combatants, they lack the multi-mission capability necessary for modern surface combatants faced with multiple, high-technology threats. They also offer limited capacity for growth. Despite this, the FFG 7 class is a robust platform, capable of withstanding considerable damage.

- (1) Class: OLIVER HAZARD PERRY
- (2) Length: 445 ft
- (3) Beam: 45 ft
- (4) Speed: 29+ kts
- (5) Crew: 17 officers, 198 enlisted
- (6) Armament: MK-46 Torpedoes, one MK 75 76mm/62 caliber gun system, one MK 15 Phalanx CIWS, and small arms.
- (7) Propulsion: Two General Electric LM 2500 gas turbine engines; 1 shaft, 41,000 shaft horsepower total.
- (8) Aircraft: 1-2 MH-60 Seahawks



e. **Coastal Patrol Ships (PC).** The primary mission of these ships is coastal patrol and interdiction surveillance, an important aspect of littoral operations outlined in the Navy's

3 Jul 14

maritime strategy. The Cyclone-class PCs are particularly suited for the maritime homeland security mission and have been employed jointly with the U.S. Coast Guard to help protect our nation's coastline, ports and waterways from terrorist attack; in addition, the ships have been forward deployed to the Gulf region in support of the war on terrorism.

(1) Class: CYCLONE

(2) Length: 179 ft

(3) Beam: 25 ft

(4) Speed: 35 kts

(5) Crew: 4 officers, 24 enlisted

(6) Armament: One MK-38 25mm machine gun; five .50 caliber machine guns; two MK 19 40mm automatic grenade launchers; two M-60 machine guns.

(7) Propulsion: Four Paxman diesels; four shafts; 3,350 shaft horsepower.



INDEPENDENCE VARIANT



FREEDOM VARIANT

f. **Littoral Combat Ships (LCS)**. LCS is a fast, agile, focused-mission platform designed for operation in near-shore environments yet capable of open-ocean operation. It is designed to defeat asymmetric anti-access threats such as mines, quiet diesel submarines and fast surface craft. The LCS class consists of two variants, the Freedom variant and Independence variant. These seaframes will be outfitted with reconfigurable payloads, called "Mission Packages", which can be changed out quickly. Mission packages are supported by special detachments that will deploy manned and unmanned vehicles and sensors in support of mine, undersea and surface warfare missions.

(1) INDEPENDENCE Variant

(a) Length: 419 ft.

(b) Beam: 103.7 ft

(c) Speed: 40+ kts

(2) FREEDOM Variant

(a) Length: 378 ft.

(b) Beam: 57.4 ft.

(c) Speed: 40+ kts



g. **Mine Counter Measures Ship (MCM).** MCMs are designed to clear mines from vital waterways. *Avenger* class ships are designed as mine sweepers/hunter-killers capable of finding, classifying and destroying moored and bottom mines. These ships use sonar and video systems, cable cutters and a mine detonating device that can be released and detonated by remote control. They are also capable of conventional sweeping measures. The ships are of fiberglass sheathed, wooden hull construction.

(1) Class: AVENGER

(2) Length: 224 ft

(3) Beam: 39 ft

(4) Speed: 14 kts

(5) Crew: 8 officers, 76 enlisted

(6) Armament: Mine neutralization system

3 Jul 14

(7) Propulsion: Four diesels (600 horsepower each), two shafts with controllable pitch propellers.



TARAWA CLASS (LHA)



AMERICA CLASS (LHA) [2014]



WASP CLASS (LHD)

h. **Amphibious Assault Ships - LHA/LHD.** The largest of all amphibious warfare ships; resembles a small aircraft carrier; capable of Vertical/Short Take-Off and Landing (V/STOL), Short Take-Off Vertical Landing (STOVL), Vertical Take-Off and Landing (VTOL) tilt-rotor and Rotary Wing (RW) aircraft operations; contains a well deck to support use of Landing Craft, Air Cushioned (LCAC) and other watercraft. Modern U.S. Navy Amphibious Assault Ships project power and maintain presence by serving as the cornerstone of the Amphibious Readiness Group (ARG)/Expeditionary Strike Group (ESG). A key element of the Seapower 21 pillars of Sea Strike and Sea Basing, these ships transport and land elements of the Marine Expeditionary Unit or Marine Expeditionary Brigade with a combination of aircraft and landing craft.

(1) TARAWA Class (LHA)

(a) Length: 820 ft

(b) Beam: 106 ft

(c) Speed: 24 kts

(d) Crew: 82 officers, 882 enlisted + 1,900 Marine detachment.

(e) Armament: 2 Rolling Airframe Missiles (RAM) launchers; 2 MK-15 20mm Phalanx CIWS; .50 caliber machine guns; 25 mm MK-38 machine guns.

(f) Propulsion: Steam

(g) Aircraft: 12 CH-46 Sea Knight Helicopters; 4 CH-53 Sea Stallion Helicopters; 3 UH-1 Huey Helicopters; 4 AH-1W Super Cobra Helicopters; 6 AV-8B Harrier attack aircraft.

(h) Landing Craft: 4 Landing Craft, Utility (LCU); 2 LCUs and 1 Landing Craft Air Cushion (LCAC) 17 Landing Craft, Mechanized (LCM-6); or 45 Amphibious Assault Vehicles (AAV).

(2) America Class (LHA)

(a) Length: 844 ft

(b) Beam: 106 ft

(c) Speed: 22+ kts

(d) Crew: 65 officers, 994 enlisted + 1,687 Marine detachment (+184 surge).

(e) Armament: 2 Rolling Airframe Missiles (RAM) launchers; 2 NATO Sea Sparrow launchers (with Evolved Sea Sparrow Missile [ESSM]); 2 MK-15 20mm Phalanx CIWS; 7 twin .50 caliber machine guns.

(f) Propulsion: Gas Turbine Engines

(g) Aircraft: A mix of F-35B Joint Strike Fighters (JSF) STOVL aircraft; MV-22 Osprey VTOL tiltrotors; CH-53 Sea Stallion Helicopters, UH-1Y Huey helicopters, AH-1Z Super Cobra helicopters, MH-60S Seahawk Helicopters.

(h) Landing Craft: None. *America* class does not have a well deck.

(3) WASP Class (LHD)

(a) Length: 844 ft

(b) Beam: 106 ft

(c) Speed: 20+ kts

(d) Crew: 66 officers, 1,004 enlisted + 1,894
Marine detachment

(e) Armament: 2 Rolling Airframe Missiles (RAM)
launchers; 2 NATO Sea Sparrow launchers; 2-3 MK-15 20mm Phalanx
CIWS; .50 caliber machine guns; 25 mm MK-38 machine guns.

(f) Propulsion: Steam, Gas Turbine for LHD-8 only

(g) Aircraft: 12 CH-46 Sea Knight Helicopters; 4
CH-53 Sea Stallion Helicopters; 3 UH-1 Huey Helicopters; 4 AH-1W
Super Cobra Helicopters; 6 AV-8B Harrier attack aircraft.

(h) Landing Craft: 2 LCUs; 3 LCACs; 6 Landing
Craft, Mechanized (LCM-8); or 40 Amphibious Assault Vehicle
(AAV).



AUSTIN CLASS



SAN ANTONIO CLASS

i. **Amphibious Transport Dock Ships (LPD):** Amphibious transport dock ships are warships that embark, transport, and land elements of a landing force for a variety of expeditionary warfare missions. LPDs are used to transport and land Marines, their equipment, and supplies by embarked LCACs or conventional landing craft and Expeditionary Fighting Vehicles (EFV) or AAVs augmented by helicopters or vertical take-off and landing aircraft (MV 22). These ships support amphibious assault, special operations or expeditionary warfare missions and can serve as secondary aviation platforms for amphibious ready groups.

(1) AUSTIN Class (AFSB(I)): USS PONCE was modified in 2012 and redesignated to an Afloat Forward Staging Base (Interim) to support mine-sweeping MH-53 Sea Dragon Helicopters

3 Jul 14

and mine clearance vessels and is the first floating staging base for military operations or humanitarian assistance.

- (a) Length: 570 ft
- (b) Beam: 84 ft
- (c) Speed: 21 kts
- (d) Crew: 29 Officers, 487 enlisted
- (e) Armament: 2 25mm Mk 38 guns, 2 Phalanx CIWS, 8 .50 caliber guns, laser.
- (f) Propulsion: Steam

(2) Class: SAN ANTONIO

- (a) Length: 684 ft
- (b) Beam: 105 ft
- (c) Speed: 22+ kts

(5) Crew: 28 officers, 333 enlisted + 800 Marines detachment

(6) Armament: 2 RAM Launchers; 2 Bushmaster 30mm Close-in-Guns, 10 .50 caliber machine guns.

(7) Propulsion: Diesel

(8) Aircraft: 2 CH53E Super Stallion Helicopters, 4 CH-46 Sea Knight Helicopters, or 2 MV-22 Osprey tilt-rotor aircraft.

(9) Landing Craft: 2 LCACs or 1 LCU and 14 AAVs.



3 Jul 14

j. **Amphibious Dock Landing Ships (LSD).** Dock Landing Ships support amphibious operations including landings via LCACs, conventional landing craft and helicopters, onto hostile shores.

(1) HARPERS FERRY Class

(a) Length: 609 ft

(b) Beam: 84 ft

(c) Speed: 20+ kts

(d) Crew: 22 officers, 397 enlisted + 402 Marine detachment

(e) Armament: Two 25mm MK 38 Machine Guns, Two 20mm Phalanx CIWS mounts and Six .50 cal. machine guns, two RAM mounts.

(f) Propulsion: Diesel: Four Colt Industries, 16 Cylinder Diesels, two shafts, 33,000 shaft horsepower

(g) Aircraft: None carried, but can land any helicopter in the USN/USMC inventory.

(h) Landing Craft: Two LCAC.

(2) WHIDBEY ISLAND Class

(a) Length: 609 ft

(b) Beam: 84 ft

(c) Speed: 20+ kts

(d) Crew: 27 officers, 380 enlisted + 500 Marines detachment

(e) Armament: Two 25mm MK 38 Machine Guns; Two 20mm Phalanx CIWS mounts and Six .50 cal. machine guns, two RAM mounts.

(f) Propulsion: Diesel: Four Colt Industries, 16 Cylinder Diesels, two shafts, 33,000 shaft horsepower

(g) Aircraft: None carried, but can land any helicopter in the USN/USMC inventory

(h) Landing Craft: 3 LCUs, 4 LCACs, or 55 AAVs.



k. **Amphibious Command Ships (LCC).** Amphibious Command ships provide command and control for fleet commanders (SIXTH and SEVENTH Fleets). Command ships provide communications and accommodations for fleet commanders and staff. Ships are equipped with air and surface radars, helicopter, chaff launchers, and an electronic warfare suite.

(1) Class: BLUE RIDGE

(2) Length: 634 ft

(3) Beam: 108 ft

(4) Speed: 23 kts

(5) Crew: 34 officers, 564 enlisted.

(6) Armament: None

(7) Propulsion: Two boilers, one geared turbine, one shaft; 22,000 horsepower.

(8) Aircraft: All helicopters but the CH-53 Sea Stallion can be carried.



3 Jul 14

1. USS CONSTITUTION is the oldest commissioned ship in the U.S. Navy. It was one of six wooden hulled, three-masted frigates authorized to form the U.S. Navy for use against the Barbary pirates.

(1) Length: 204 ft

(2) Beam: 43.5 ft

(3) Height: Fore: 198 ft; Main: 220 ft; Aft: 172.5 ft

(4) Speed: 13+ kts

(5) Crew: 2 officers and 52 enlisted

(6) Propulsion: Sail

C012. Submarines



a. **Fleet Ballistic Missile Submarines (SSBN).** Ballistic missile submarines, often referred to as "boomers," serve as an undetectable launch platform for intercontinental missiles. They are designed specifically for stealth and the precise delivery of nuclear warheads. SSBNs are specifically designed for extended deterrent patrols.

(1) OHIO Class

(a) Length: 560 ft

(b) Beam: 42 ft

(c) Crew: 15 officers, 140 enlisted

3 Jul 14

(d) Armament: 24 tubes for Trident II submarine-launched ballistic missiles, MK48 torpedoes, four torpedo tubes.

(e) Propulsion: One nuclear reactor, one shaft.



b. **Guided Missile Submarine (SSGN):** Provide the Navy with an unprecedented combination of strike and special operation mission capability within a stealthy, clandestine platform. Armed with tactical missiles and equipped with superior communications capabilities, SSGNs are capable of directly support dozens of Special Operation Forces.

(1) OHIO Class (Converted)

(a) Length: 560 ft

(b) Beam: 42 ft

(c) Crew: 15 officers, 140 enlisted

(d) Armament: Up to 154 Tomahawk missiles, Mk48 torpedoes; 4 torpedo tubes.

(e) Propulsion: One nuclear reactor, one shaft.



3 Jul 14

c. **Fast Attack Submarines (SSN):** Attack submarines are designed to seek and destroy enemy submarines and surface ships; project power ashore with Tomahawk cruise missiles and Special Operation Forces; carry out Intelligence, Surveillance, and Reconnaissance missions; support battle group operations, and engage in mine warfare.

(1) LOS ANGELES Class

(a) Length: 362 ft.

(b) Beam: 33 ft.

(c) Crew: 15 Officers, 120 enlisted

(d) Armament: Tomahawk missiles, VLS tubes (SSN 719 and later), MK48 torpedoes, four torpedo tubes.

(e) Propulsion: One nuclear reactor, one shaft

(2) VIRGINIA Class

(a) Length: 377 ft.

(b) Beam: 34 ft.

(c) Crew: 15 Officers, 120 enlisted

(d) Armament: Tomahawk missiles, VLS tubes, MK48 torpedoes, four torpedo tubes.

(e) Propulsion: One nuclear reactor, one shaft

(3) SEAWOLF Class

(a) Length: SSN 21 and 22: 353 ft; SSN 23: 453 ft

(b) Beam: 40 ft.

(c) Crew: 14 Officers 126 enlisted

(d) Armament: Tomahawk missiles, MK48 torpedoes, eight torpedo tubes.

(e) Propulsion: One nuclear reactor, one shaft

3 Jul 14

C013. Combatant Commanders

a. Geographic Combatant Commanders

(1) USNORTHCOM - United States Northern Command.
Headquarters located at Peterson Air Force Base, Colorado.

(2) USSOUTHCOM - United States Southern Command.
Headquarters located in Miami, Florida.

(3) USEUCOM - United States European Command.
Headquarters located at Patch Barracks, Germany.

(4) USPACOM - United States Pacific Command.
Headquarters located at Camp H. M. Smith, Hawaii.

(5) USCENTCOM - United States Central Command.
Headquarters located at Macdill Air Force Base, Florida.

(6) USAFRICOM - United States Africa Command.
Headquarters located at Kelley Barracks, Germany.

b. Functional Combatant Commanders

(1) USSTRATCOM - United States Strategic Command.
Headquarters located at Offutt Air Force Base, Nebraska.

(2) USSOCOM - United States Special Operations Command.
Headquarters located at Macdill Air Force Base, Florida.

(3) USTRANSCOM - United States Transportation Command.
Headquarters located at Scott Air Force Base, Illinois

Page Intentionally Left Blank

3 Jul 14

APPENDIX D**ROOM LOCKER AND PERSONNEL INSPECTION REQUIREMENTS**

D001. Purpose. The RLP tests a candidate's ability to read, comprehend, and execute regulations with an emphasis on attention to detail.

D002. Inspectors. The inspectors for the RLP will be Drill Instructors and RDCs assigned to OTCN.

D003. Room. The rooms and all contents within will be clean. All gear will be stowed in its proper place in accordance with this instruction and Class Team guidance. The lights will be on during the inspection. Window curtains will be open. All other spaces assigned to the class will be inspected for general cleanliness and proper stowage.

a. Shower Area. The shower area shall be clean and free of any gear or contraband. Candidates are responsible for their own side of the shower area. Recorded discrepancies from the shower area will be documented on the grading sheet of both candidates responsible for that space.

(1) Shower Curtain. The shower curtain will be clean. The shower curtain will be completely attached to the shower curtain rod with no breaks in the attachment holes. The curtain will be opened and grounded to the center of the shower stall.

(2) Shower Area Bench. The shower area bench will be stowed in the down position.

b. Sink. The sink will be clean and free of any gear or contraband. The compartment under the sink will be empty with the starboard door open at a 90 degree angle. Recorded discrepancies from the sink area will be documented on the grading sheet of both candidates responsible for that space.

c. Head. The head will be clean and free of any gear or contraband. The door to the head will be fully open and grounded against the nearest door of the compartment under the sink. The toilet bowl seat and lid will be in the UP position. Recorded discrepancies from the head will be documented on the grading sheet of both candidates responsible for that space.

D004. Uniform. The uniform for the RLP will be the Navy Working Uniform (NWU) worn in accordance with chapter 5 of this instruction.

3 Jul 14

D005. Knowledge. Candidates are responsible for reciting all knowledge in Appendix B verbatim.

D006. Desk Assembly: (desk, chair, and hutch). The desk assembly will be clean and contraband free. All drawers will be empty. When available the OCR will be placed on the assembly at the class team discretion. The chair will be tucked and centered under the desk.

D007. Rack. The rack will be positioned and made IAW chapter 3 of this instruction. Candidates will place all items not involved with the RLP inspection inside of their sea bags and place them in the coffin locker of their rack. Racks will be locked with combination locks set to zero.



Picture 1

a. Rifle. Displayed assembled on the rack. The rifle will be centered on the rack, with the barrel six (6) inches from the closest fold towards the head of the rack. The rifle will be displayed with a parade sling, ejection cover up, and on safe. Ownership markings are removed. The rifle must be clean and free of rust, dirt or excessive oil.

D008. Wall Locker. The wall locker doors will be opened 90 degrees. Combination locks will be locked, set to zero and grounded to the locker door.



Picture 2

a. Footgear. Footgear will be stowed on top of the wall locker (see picture above). Toes of shoes will be grounded to the front edge of the wall locker. The first pair of shoes will be grounded to the edge on the port side of the locker and arranged in the following order: black, white, athletic and shower shoes. Shoes shall be polished and laced in accordance with chapter 5 of this instruction. All footwear will be clean and free contraband.

b. Upper Compartment



Picture 3

(1) Navy PT Shirt, Sweatshirt, and Sweatpants. Folded twelve (12) inches by twelve (12) inches. Stacked from top to bottom: One (1) each Navy PT shirt, sweatshirt, and sweatpants. Placed with the single folded edge grounded to the front and port of the shelf.

3 Jul 14

(2) Combination Cover Khaki Cap and NWU Eight Point Cover. The khaki combination cover cap will be displayed with the aft seam forward, measured 9 inches from the starboard edge of the PT stack to the seam. Khaki cover will be even with the flange of the garage frame. The NWU eight point cover will be displayed centered, on top of khaki cover, bill forward, and grounded even with both the flange of the garage frame and the khaki cover. Refer to Picture 3 for further guidance.

(3) Watch Cap. Displayed flat with the top of the cap forward, grounded starboard, and even with the front edge of the shelf. Refer to Picture 3 for further guidance.

(4) White Shoebox. Ground lengthwise to aft corner stanchion and widthwise to starboard, hinged side aft. Inside of box will be empty. Refer to Picture 3 for further guidance.

(5) Black Shoebox. Ground lengthwise to aft corner stanchion and widthwise to port, hinged side aft. Inside of box will be empty. Refer to Picture 3 for further guidance.

c. Hanger Rod. All uniform pockets will be empty.

(1) Uniform Display. Uniforms will be displayed from port to starboard:

(a) All-Weather Coat.

(b) Jacket, Black, Relaxed Fit.

(c) NWU Parka W/Liner.

(d) NWU last-worn uniform.



Picture 4



Picture 5

* The uniform worn during the inspection will not be displayed in the wall locker and the hangers of that uniform will be removed from the wall locker. The remaining hangers will be evenly spaced from the port of the wall locker as you look at it to the port of the chest of drawers as you look at it with the first hanger grounded against the wall locker. Hangers of the same type will be used and will be hung with the open end of the hanger facing the back of the wall locker.

(1) All-Weather Coat and Liner. Buttons facing starboard. Button all buttons except the top button. The small collar button on the port side will be buttoned. Cuff will be buttoned to the outer button such that both buttons are visible when displayed. Liner will be completely zipped and zipper grounded.

(2) Relaxed fit Jacket and Liner. Zipper will be to starboard, completely zipped up and zipper grounded with liner attached at all Velcro tabs.

(3) NWU Parka and Liner. Zipper will be to starboard, completely zipped with zipper grounded. The liner will be completely zipped and zipper grounded. All Velcro will be closed evenly and tightly.

(4) Last Uniform Worn. All items will be removed from trousers and shirt, pockets emptied, and all buttons buttoned as the uniform was last worn.

3 Jul 14

(a) Trousers will be hung such that the cuff and top of the waist are even, with zipper forward and legs to starboard. Zippers will be closed and grounded with the fly closure latched.

(b) Center the belt (web) on the trousers with brass clip to starboard and stenciled name exposed. The belt will be evenly folded on the hanger. Picture 5 is showing belt over the NWU shirt to display placement over trouser.

(c) The shirt will be hung on the hanger over the trouser and belt, with the front of shirt to starboard. The shirt sleeves will be displayed according to the seasons. During summer the sleeves will be rolled properly and displayed. During winter the shirt sleeves will not be rolled.

d. Chest of Drawers. All drawer-opening measurements are measured from the vertical front section of the chest to the inboard edge of the drawer face.

(1) Top Shelf

(a) Gearbox (inside). Picture 6. The gearbox will be displayed as listed from aft to front and grounded to the starboard side of the wall locker. Gearbox contains the shoe-polish kit, name-stamp kit, sewing-kit, scotch tape, and nametag. Arrange all items neatly. Place the nametag forward and centered with the name upright and visible through the front of the gearbox. Cover of box will be sealed tightly.



Picture 6

3 Jul 14

(b) Khaki Garrison Cap: Placed on top of the gearbox with starboard side of cover down and grounded forward and starboard on the gear box.

(c) Black Gloves. Displayed to the port of the gearbox, palms together, thumb forward and tucked in, thumbs grounded to port side of gearbox, fingers facing forward with longest finger even with forward edge of the gear box.

(d) Ruler. The ruler will be centered and grounded to the forward edge of the chest of drawers with the measurement side pointing forward.

(2) Top Drawer. Open three (3) inches. See picture 11 (display). See picture 7 (arrangement)



Picture 7

(a) Black Dress Socks. Folded neatly in four (4)-inch length. Two pairs of black service socks are placed side-by-side:

1 The first sock is grounded aft and starboard with the open end facing aft and the admiral smile facing forward.

2 The second sock is grounded aft and port to the first sock, open end facing aft and the admiral smile facing forward.

(b) Athletic Socks. Folded neatly in six (6)-inch lengths, placed two pair in a stack, grounded forward and starboard with the open end facing aft and the admiral smile facing forward.

(c) Boot Socks (Black). Folded neatly in six (6)-inch lengths, place two pair in a stack, grounded forward and

3 Jul 14

port of the athletic socks with the open end facing aft and the admiral smile facing forward.

(d) White Dress Socks. Candidates will place one (1) pair of white service socks folded neatly four inches in length grounded aft of the athletic socks, with the open end grounded to the starboard edge of the drawer and the admiral smile facing inboard.

(e) Laundry Bag. One (1) laundry bag folded into thirds lengthwise and then in half widthwise, grounded port and forward, with the single folded edge port and forward.

(f) Reflective Belt. One (1) reflective belt folded six (6) inches lengthwise. The buckle of the reflective belt will be facing up. Belt will be placed length wise grounded forward to the front of the drawer centered on the laundry bag.

Rest of Page

Intentionally

Left Blank

(3) Middle Drawer. Open six (6) inches. See picture 11 (display). See Picture 9 (arrangement).



Picture 9

(a) Undershirts (Blue). Folded six (6) inches by six (6) inches. Grounded to port and to aft, three (3) high in a stack, with the folded single edge forward. The front of the shirts will be facing up.

(b) Undershirts (White). Folded six (6) inches by six (6) inches. Grounded forward and to port, three (3) high in a stack, with the folded single edge forward. The front of the shirts will be up.

(c) Physical Training Shorts. Folded six (6) inches by six (6) inches. Grounded starboard and aft, two (2) high in a stack, with the single folded edge forward.

(4) Bottom Drawer. Open nine (9) inches. See Picture 11 (display). See picture 10 (arrangement).



Picture 10

(a) Towels. Folded into thirds lengthwise and then into thirds widthwise. One towel will be grounded forward port, one will be grounded forward starboard.

3 Jul 14

(b) Washcloth. One (1) washcloth folded in half widthwise and placed on top of each towel grounded forward, centered with the single folded edge to port.

e. Book Bag. The book bag will be placed in the wall locker with the latches facing port as you are looking at it. The book bag will be to the port of the chest of drawers and grounded to the chest of drawers as you are looking at it. The carrying strap will be removed. If the style of book bag is such that the carrying strap cannot be removed, the strap will be tightened. The shoulder pad will be in a vertical position protruding from the starboard side of the book bag or to the front as you are looking at it. A canteen will be placed in the large zipper pocket of the book bag. The zipper will be closed. The marking on the canteen will be clean. The canteen will be full.



Picture 11

D009. Quarterdeck. The Nimitz Hall secondary quarter deck is designated as the class' responsibility and will be clean and free of contraband. All wastebaskets on the quarter deck will be emptied with a clean plastic liner installed. Any common spaces or storage spaces will be clean and neatly stowed with only authorized materials. All decks will be highly shined. All carpet will be vacuumed

3 Jul 14

D010. Warnings. The class section leader will give a 30-minute, 15-minute, 5-minute and immediate warning prior to the inspection.

D011. Procedures

a. Students will stand at parade rest outside their hatch beginning at the 5 minute warning. Students will remain at parade rest until their inspector has squared off in front of them.

b. When a Class Drill Instructor or RDC squares off in front of a candidate, the candidate will come to attention and give the proper greeting of the day, followed by "Officer Candidate {name}, room {####}". The Drill Instructor/RDC will give the command, "Hand salute." The Drill Instructor/RDC will then inspect the candidate's salute for correctness. Upon completion, the Drill Instructor/RDC will give the command, "Ready, two." The candidate will cut the salute, return to the position of attention, and await further instruction.

c. After being inspected, the candidate will uncover and return to parade rest outside the room and hydrate. When the room is complete and the last candidate has been inspected, both candidates will wait for instructions from their Class Team.

D012. Failures. Any candidate who fails to achieve a score of 80% or above will normally be re-inspected within 48 hours. Failure to achieve a score of 80% or above on the re-inspection will result in an immediate roll back of that candidate to H Class or the next junior OCS class.

a. Automatic Failures. The following discrepancies will result in an automatic failure for the inspection:

- Failure to fill out the inspection sheet.
- Missing an inspection item.
- Unsanitary Head.

D013. Grades. Scores will be recorded on the candidate's hard card. All candidates will receive the original raw score for the event, regardless of re-inspection score, computation of final class average. The final class average will include the original raw scores of any candidate who fails re-inspection even though that candidate is no longer with the class.

Room, Locker, and Personnel Inspection MILITARY TRAINING TEST

Name: OC _____

Room: _____ Class: _____ Date: _____

Inspector: _____

Recorder: _____

COMMON AREAS:

Deck (1) _____
 Head (1) _____
 Mirror (1) _____
 Room (1) _____
 Shower Area (2) _____
 Sink/Cabinet (2) _____
 Windows (Glass) (1) _____
 Windowsill/frame (1) _____

CANDIDATE/UNIFORM:

Cover (2) _____
 Bearing/Attitude (2) _____
 Belt (2) _____
 Boots (2) _____
 Buckle (2) _____
 Hygiene (2) _____
 Knowledge (5) _____
 Salute/Greeting (2) _____
 Shirt (2) _____
 Trousers (2) _____

RACK/RIFLE:

Bed (1) _____
 Blanket (1) _____
 Pillow (1) _____
 Rifle Display (2) _____
 Sheets (1) _____

DESK ASSEMBLY:

Chair (1) _____
 Desk/Hutch (1) _____
 OCR (1) _____

DISCREPANCY LEGEND

Contraband(CB)

Dirty(D)
 Fold (F)
 Improper Display (ID)
 Improper Marking(IM)
 Improper Wear (IW)
 Measurements(M)
 Press(P)
 Strings(ST)

WALL LOCKER

TOP SHELF/TOP COMPARTMENT:

8 Point Cover (2) _____
 Black Shoe Box (2) _____
 Combination Cover (2) _____
 Footwear (2) _____
 PT Stack (2) _____
 Watch Cap (2) _____
 White Shoe Box (2) _____

MAIN COMPARTMENT/HANGER ROD:

All Weather Coat (2) _____
 Belt (2) _____
 Hanger Spacing (1) _____
 Jacket, Black (2) _____
 Parka & Liner (2) _____
 Shirt (2) _____
 Trouser (2) _____

MAIN COMPARTMENT/CHEST OF DRAWERS:

Athletic Socks (2) _____
 Black Dress Socks (2) _____
 Black Gloves (2) _____
 Boot Socks (2) _____
 Drawer Measurements (1) _____
 Garrison Cap (2) _____
 Gear Box (2) _____
 Knowledge Bag (2) _____
 Laundry Bag (2) _____
 PT Shorts (2) _____
 Reflective Belt (2) _____
 Towels (2) _____
 Undershirt, Blue (2) _____
 Undershirt, White (2) _____
 Washcloth (2) _____
 White Dress Socks (2) _____

OVERALL SCORE (100) _____

Pass _____ Fail _____

Page Intentionally Left Blank

3 Jul 14

APPENDIX E**OFFICER PERSONNEL INSPECTION REQUIREMENTS**

E001. Purpose. The primary purpose of the Officer Personnel Inspection (OPI) is to check for confidence and competence before entering the Candidate Officer/Applied Leadership phase of OCS. Secondary purposes of the OPI are to ensure Officer Candidates can properly follow orders given by senior officers and can properly wear seasonal dress uniforms.

E002. Inspectors. Inspectors for the OPI will be officers of the rank Lieutenant or Lieutenant Junior Grade assigned to OTCN.

E003. Room. The rooms, windows, curtains, decks, and all furniture will be clean. All items not being inspected shall be stowed in the war locker (a.k.a. room locker). The lights will be on for the inspection. Window curtains will be open.

E004. Uniform. The uniform for the OPI will be the seasonal pre-graduation reception uniform worn in accordance with the uniform section of this instruction.

E005. Knowledge. Candidates are responsible for all knowledge in Appendix B verbatim. Candidates are responsible for a working knowledge of all items in Appendix C.

E006. Desk Display. Desks will be arranged IAW chapter 3 of this instruction. The Class Team will provide additional guidance to occupants of rooms with unique geometry or furniture.

a. Grading Sheet. The grading sheet will be grounded to the starboard side of the OCR and grounded to the bottom seam of the desk. Each candidate will fill out the top of the grading sheet with name, room, class and date.

b. Ruler. The ruler will be grounded to the top of the grading sheet.

c. Pen. The pen will be grounded to the starboard side of the grading sheet with the top of the cap of the pen aligned with the top of the grading sheet.

d. Chairs. Centered port and starboard with the chair seat under the desk and chair backs grounded to the desk.

3 Jul 14

e. Buckle and Insignia Display. The devices will be arranged on the desk as shown in figure E.1.

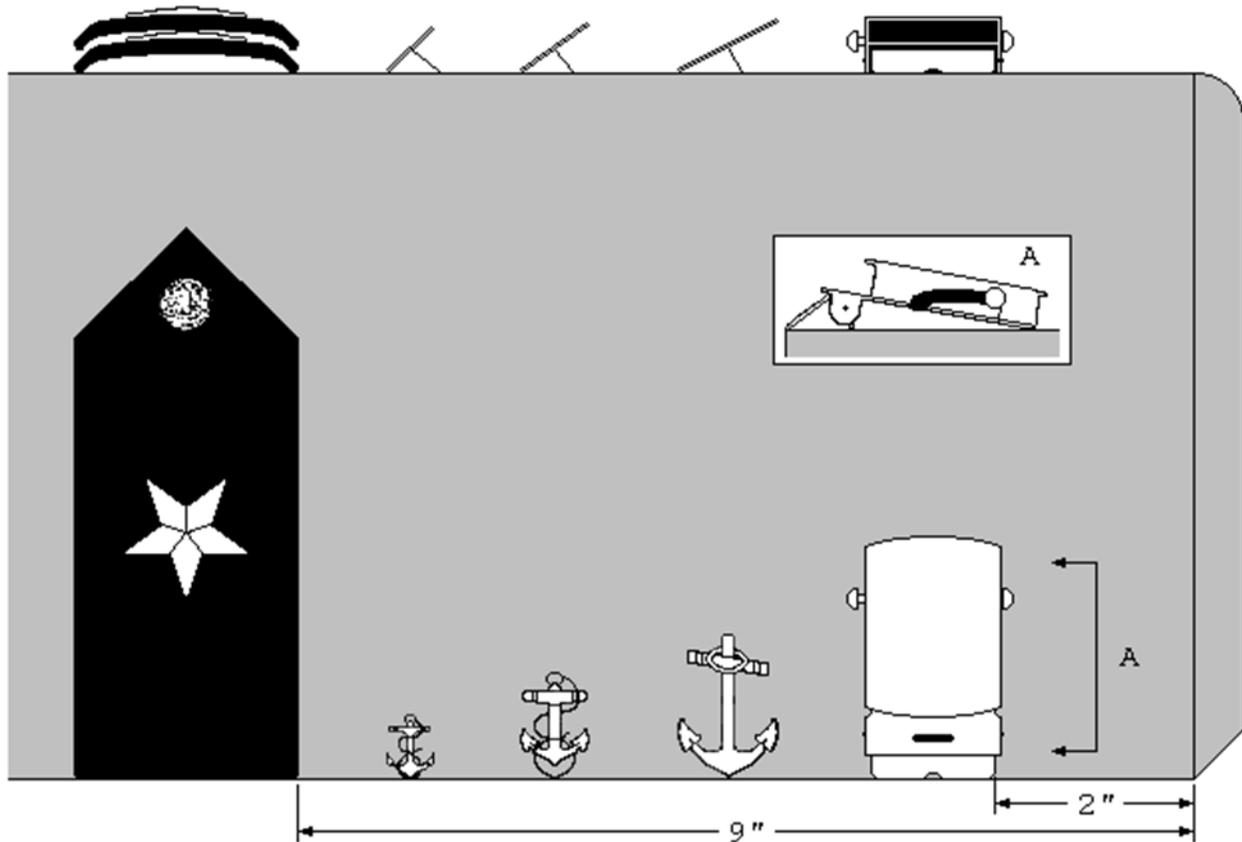

Figure E.1

(1) Buckle. Positioned two inches from the starboard seam of the desk and with the claw toward the center of the room. Ground the claw of the buckle to the forward seam of the desk with the claw fully extended. The buckle spindle will be grounded in the "locked" position. Buckle will be clean.

(2) Shoulder Boards. Placed nine inches from starboard seam of the desk to the inboard edge of the shoulder board. Ground the squared end against the forward seam of the desk. Stack the boards so the rank is displayed one on top of the other. Shoulder board clips will be fastened and will be free of threads, lint, and dirt. Hard shoulder boards will be displayed during the winter months. Soft shoulder boards will be displayed during the summer months.

(3) Lapel, Cap, and Collar Insignia. One of each, evenly spaced between the shoulder boards and the belt buckle

3 Jul 14

with the crowns (bottoms) of the anchors grounded against the forward edge of the desk. Display insignia by decreasing size, with the largest near the buckle:

(a) Service Dress Blue Lapel Insignia.

(b) Cap Insignia.

(c) Collar Insignia - displayed with the bitter end facing starboard.

(d) The shanks of the anchors will be perpendicular to the desk edge, frogs will be removed and the insignias will be tilted inboard to the desk. To be evenly spaced, the anchors must be the same measurement from:

(1) Inboard edge of shoulder board to the center of the tilted Collar Insignia.

(2) Center of the tilted Collar insignia to the center of the tilted Cap Insignia.

(3) Center of the tilted Cap Insignia to the center of the tilted Service Dress Blue Lapel Insignia.

(4) Center of the tilted Service Dress Blue Lapel Insignia to the belt buckle inboard edge.

(e) During the winter months, candidates will not display the SDB lapel insignia on the desk. In this case, evenly space the collar insignia and the cap insignia between the inboard edge of the shoulder boards and the inboard edge of the belt buckle IAW with the above paragraphs.

f. Desk Drawers. The top starboard side drawer will be open three inches, measured from the bitter end of the ruler flush with the desk to the inboard edge of the drawer. All other desk drawers shall be empty, clean and closed.

g. Stationery Box. Centered in the top starboard desk drawer and grounded to the front of the drawer. All items shall be removed from the stationary box with the exception of one envelope and one sheet of stationary paper. The envelope and stationary paper will be free of markings and grounded to the bottom edge inside the stationary box.

E007. Procedures

3 Jul 14

a. At the immediate warning, candidates will be at the position of parade rest outside their rooms.

b. When the inspecting Officers enter the passageway the candidates will call attention on deck and give the greeting of the day. "Good Morning Sir/Ma'am." The candidates will remain at attention.

c. When an Officer squares off in front of a candidate, a hand salute is rendered and the candidate sounds off, "Sir/Ma'am, Officer Candidate (last name), Room (number), standing by for inspection." They will wait to cut their salute when the salute has been returned by the Officer.

d. Candidates will use military facing movements to enter their room. Once inside the room, candidates will perform an about face approximately 18 inches from their window unless otherwise directed by the inspecting Officer.

e. After being inspected by an Officer, the candidate will place their cover on their desk, fix their uniform, return outside the hatch, go to parade rest and wait for instructions from their Class Team.

E008. Failures. Any candidate who fails to achieve a score of 80% or above will normally be re-inspected within 72 hours. Failure to achieve a score of 80% or above on the re-inspection will result in that candidate rolling to the next junior OCS class.

a. Automatic Failures. The following discrepancies will result in an automatic failure:

(1) Failure to complete the information on the inspection sheet prior to commencing the inspection.

(2) Missing an inspection item. (Unless item is noted on the deficiency list.)

D013. Grades. All actual scores will be recorded on the candidate's hard card. All candidates will receive the original raw score for the graded event, regardless of re-inspection score, for computation of final class average.

Eighth Week Personnel Inspection
MILITARY TRAINING TEST
 SERVICE DRESS BLUE UNIFORM

Name: OC

Room:

Class:

Date:

Inspector:

UNIFORM:

- | | |
|---|-------------------------------------|
| Cover (Dirt/TH/Brim) (2) _____ | Ribbons/Warfare Device (1) _____ |
| Chin strap (1) _____ | Collar Device (1) _____ |
| Insignia (1) _____ | Jacket (CB/TH/D) (4) _____ |
| Eagles (1) _____ | Gig Line / Spindle / Tuck (2) _____ |
| Dress Shirt (TH/D/P) (2) _____ | Shoes (SH/TU/TH) (2) _____ |
| Brass (1) _____ | Salute (1) _____ |
| Trouser (TH/P/D) (2) _____ | Tie/Neck Tab (1) _____ |
| POA/Greeting/Facing Movements (2) _____ | |
| Hygiene (1) _____ | |

Total (25): _____

KNOWLEDGE:

- | | |
|-------------------------------------|--|
| Oath of Office (2) _____ | Military Courtesy/Confidence (5) _____ |
| Songs/Creeds/Hymns (1) _____ | Phonetic Alphabet (1) _____ |
| Chain of Command (2) _____ | Naval Mission / Warfare (2) _____ |
| Code of Conduct (2) _____ | Leadership Trait (1) _____ |
| General Orders (2) _____ | Naval Weapon Systems (4) _____ |
| Rank Structure (Officer) (2) _____ | Naval Aircraft (4) _____ |
| Rank Structure (Enlisted) (2) _____ | Naval Ships/Subs (4) _____ |
| Breast Insignia (2) _____ | Combatant Commanders (2) _____ |
| Sleeve Devices (1) _____ | |

Total (37): _____

DESK/ROOM:

- | | |
|---------------------------------|-------------------------------------|
| Desk Measurement (1) _____ | Laptop (1) _____ |
| Buckle(ID/Grouped/CL) (2) _____ | Shoulder Boards (TH/D/ID) (2) _____ |
| Insignias (ID/CL) (1) _____ | Chair (1) _____ |
| Stationary Box (1) _____ | Drawer Measure (1) _____ |
| Contraband (5) _____ | |

Total (15): _____

Overall Total (77): _____

Eighth Week Personnel Inspection
MILITARY TRAINING TEST
 SUMMER WHITES UNIFORM

Name: OC

Room:

Class:

Date:

Inspector:

UNIFORM:

- | | |
|---|-------------------------------------|
| Cover (Dirt/TH/Brim) (2) _____ | Name Tag (1) _____ |
| Chin strap (1) _____ | Ribbons/Warfare Device (1) _____ |
| Insignia (1) _____ | Collar Device (1) _____ |
| Eagles (1) _____ | Shirt (CB/TH/D/P) (3) _____ |
| Undershirt (TH/D) (1) _____ | Gig Line / Spindle / Tuck (2) _____ |
| Brass (1) _____ | Belt (TH/D) (1) _____ |
| Trouser (TH/P/D) (2) _____ | Shoes (SH/TU/TH) (2) _____ |
| POA/Greeting/Facing Movements (2) _____ | Salute (1) _____ |
| Hygiene (1) _____ | |

Total (24): _____

KNOWLEDGE:

- | | |
|-------------------------------------|--|
| Oath of Office (2) _____ | Military Courtesy/Confidence (5) _____ |
| Songs/Creeds/Hymns (1) _____ | Phonetic Alphabet (1) _____ |
| Chain of Command (2) _____ | Naval Mission / Warfare (2) _____ |
| Code of Conduct (2) _____ | Leadership Trait (1) _____ |
| General Orders (2) _____ | Naval Weapon Systems (4) _____ |
| Rank Structure (Officer) (2) _____ | Naval Aircraft (4) _____ |
| Rank Structure (Enlisted) (2) _____ | Naval Ships/Subs (4) _____ |
| Breast Insignia (2) _____ | Combatant Commanders (2) _____ |
| Sleeve Devices (1) _____ | |

Total (37): _____

DESK/ROOM:

- | | |
|-----------------------------------|-------------------------------------|
| Desk Measurement (1) _____ | Laptop (1) _____ |
| Buckle(ID/Grouped/CL) (2) _____ | Shoulder Boards (TH/D/ID) (2) _____ |
| Insignias (Frogs/ID/CL) (1) _____ | Chair (1) _____ |
| Stationary Box (1) _____ | Drawer Measure (1) _____ |
| Contraband (5) _____ | |

Total (15): _____

Overall Total (76): _____

APPENDIX F

6th and 9th Week Personnel Inspection Procedures

1. Purpose

a. 6th week personnel inspection (6th Week PI). The purpose of the 6th week PI is to inspect each candidate for proper uniform wear in accordance with the uniform section of this instruction, haircut, shave, hygiene, general military appearance and verbatim knowledge of appendix B.

b. 9th week personnel inspection (9th week PI). The purpose of the 9th week PI is to inspect each candidate for proper uniform wear in accordance with US Navy Uniforms Regulations, haircut, shave, hygiene, general military appearance and level of knowledge of Officer Candidate Regulations (at class team discretion).

2. 6th Week Personnel Inspection Process

a. Formation. The section leader will be informed as to the time, place, and location of both inspections. The class will be formed in a platoon formation on line, at normal intervals and at open ranks.

(1) Outdoor Inspection. The section leader will be three paces out and centered on the First Squad Leader facing to the front. The class guidon will be placed in the ground, one pace in front of the section leader (when possible), starting with the back of heels on the edge of the curb. The guidon will be centered on the class.

(2) Indoor Inspection. The section leader will be three paces out and centered on the First Squad Leader facing to front. The class guidon will be one pace in front of the section leader and centered on the class.

b. Thirty (30) minutes prior to the start of the inspection, the section leader will have the class outside their hatches, standing at attention. The class will wear white t-shirts, PT shorts, white or black dress socks as dictated by the uniform for inspection, and gym shoes. The primary inspector will conduct a safety brief. The class will have thirty (30) minutes to get dressed in their service khaki uniform in

3 Jul 14

accordance with Navy Uniform Regulations and be on the assigned spot in platoon formation, at open ranks and parade rest.

c. Upon sighting the primary inspector, the section leader will come to attention, give the greeting of the day, execute a left face, order the class to attention, and execute a right face, facing back to the front. The inspectors will check for proper formation and correct placement of the guidon. When the primary inspector squares off in front of the section leader, he/she will render a hand salute, and present the class by stating, "Good morning Sir/Ma'am, Class XX-XX formed for inspection. # assigned, # standing by." The primary inspector will return the salute and issue the command, "Carry on section leader." The section leader will reply, "Aye, Aye, Sir/Ma'am."

d. The section leader will execute a left face and issue the command, "Hand, SALUTE." The class, with the exception of the section leader, will simultaneously render a hand salute. All inspectors will inspect for proper hand salutes. The primary inspector will then issue the command, "Carry on section leader." The section leader will reply, "Aye, Aye, Sir/Ma'am."

e. The section leader will give the command, "Ready, TWO." All salutes must cut simultaneously.

f. The primary inspector will issue the command, "Carry on section leader." The section leader will reply, "Aye, Aye, Sir/Ma'am." The section leader will give the command, "UNCOVER, TWO." All candidates will uncover except the section leader. The section leader will execute a right face and the inspection will commence.

g. The primary inspector will inspect the section leader first. When the primary inspector finishes inspecting the section leader, they will order the section leader to "Precede Me, section leader." The section leader will reply, "Aye, Aye, Sir/Ma'am."

h. The section leader will execute a left face and then make the appropriate movements to position themselves directly in front of and facing the second person in the first squad. The primary inspector will then inspect the first squad and the remaining inspectors will begin inspecting their assigned squads.

i. The section leader will precede the primary inspector for the first rank only. While the inspector is inspecting the

3 Jul 14

last candidate in the first squad, the section leader will post back to three paces out and centered on the first squad leader facing to the front by proceeding around the formation in a counterclockwise fashion.

j. After each squad has been inspected, the inspector will order "# squad RECOVER. The squad will reply, "Aye, Aye, Sir/Ma'am," and will recover their uniforms (gig line, buttons buttoned, and combination cover in the right hand).

k. After all candidates have been inspected, the primary inspector will give the command, "Carry on section leader." The section leader will reply, "Aye, Aye Sir/Ma'am," execute a left face, order "COVER, TWO." When all motion has stopped, the section leader will execute a right face and await the inspecting officer.

l. When the inspecting officers have finished inspecting the candidates for proper uniform recovery, the primary inspector will square off in front of the section leader. The section leader will salute, and give the greeting of the day. When the inspecting officers depart, the section leader will command the platoon to "parade REST", face to the front, go to parade rest, and await further instructions from their Class Chief Petty Officer.

3. 9th Week Personnel Inspection Process

a. Thirty (30) minutes prior to the start of the inspection, the section leader will have the class outside their hatches, standing at attention. The class will wear white t-shirts, PT shorts, white or black dress socks as dictated by the uniform for inspection, and gym shoes. The Class Chief will conduct a safety brief. The class will have thirty (30) minutes to get dressed in the seasonal graduation uniform in accordance with Navy Uniform Regulations. The location will be in individual Candidate rooms, Class passageway, or Kill Zone, as designated by Class Chief Petty Officer. Class Chief Petty Officer will designate formation and procedures.

PASSING STANDARDS

651. Applicability. This section applies to all Military Training Test (MTT) inspections except Welcome Aboard, which is a pass/fail event.

3 Jul 14

652. Promulgation. Candidates must score a minimum of 80% on the Room Locker Personnel Inspection (RLP) and Personnel Inspections. Specific grading criteria, score sheets, and hits available will be promulgated prior to inspection. The MTT grade sheets in Appendix D can be used for reference only. The class team will provide final guidance.

653. Passing/Failing. An individual candidate passes or fails an MTT. Failure results in documented formal counseling and re-inspection.

a. Re-inspection. If a re-inspection is to be conducted, the re-inspection time and location will be provided at the time of counseling. Re-inspection shall usually be within 24-48 hours.

b. Re-inspection Grade. To advance in training, candidates who fail must pass a re-inspection. If a student fails an MTT re-inspection, that student will automatically be assigned to the next junior OCS and repeat the inspection. All actual scores will be recorded on the candidate's hard card. The candidate will receive the original raw score for passing the graded event, regardless of re-inspection score, for computation of final average.

**6th Week Personnel Inspection
MILITARY TRAINING TEST**

Name: OC _____ Room: _____ Class: _____ Date: _____

Inspector: _____ Recorder: _____

UNIFORM

Cover (4) _____

Ribbons (2) _____

Name Tag (2) _____

Collar Devices (1) _____

Hygiene (2) _____

Gig Line (1) _____

Military Bearing (2) _____

Shoes (2) _____

Shirt (3) _____

Trouser (2) _____

Warfare Devices (2) _____

Belt/Buckle (4) _____

UNIFORM SCORE (27) _____

KNOWLEDGE:

Questions (3) _____

KNOWLEDGE SCORE (3) _____

OVERALL SCORE (30)

P _____ F _____

DISCREPANCY LEGEND

Strings (ST)

Measurements (M)

Contraband (CB)

Improper Marking (IM)

Dirty/Smudged (D)

Press (P)

Excessive Movement (EM)

Improper Wear (IW)

Metal to Metal (MM)

Spindle not grounded (SG)

Shine (S)

6TH WEEK PERSONNEL INSPECTION

DATE: _____ CLASS: _____ PRIMARY INSPECTOR: _____

SECONDARY INSPECTOR: _____

CLASS INSPECTION ITEMS

- a. Time _____
- b. On Spot _____
- c. Alignment _____
- d. Depth _____
- e. Width _____
- f. Formation _____

TOTAL POINTS: _____

SECTION LEADER COMMANDS

- a. Attention _____
- b. Hand Salute _____
- c. Two _____
- d. Uncover _____
- e. Two _____
- f. Cover _____
- g. Two _____
- h. Parade Rest _____

TOTAL POINTS: _____

* Points taken from the Class Inspection Items, and Section Leader Commands will be deducted from the final class average at a rate of .5 percentage point per hit. All other hits will be considered individual hits and will be deducted from the individual.

APPENDIX G

OFFICER CANDIDATE SCHOOL FORMS

1. Included in this Appendix are the following forms:
 - a. Special Request/Authorization
 - b. Candidate Report Chit
 - c. Demerit Documentation Form
 - d. OCR Change Recommendation Form
 - e. Record of Counseling
 - f. Leave Request/Authorization
2. Instructions on how to properly fill out or use these forms are contained in this section.
3. These forms shall remain in this instruction and shall be photocopied if required.

3 Jul 14

Instructions for Special Request/Authorization Form

The purpose of the Special Request/Authorization Form, also known as a Special Request Chit, is to request such things as Special Liberty, Special Pay or requests for periods of absence (generally not entertained at OCS).

1. Name - First, Middle Initial, Last. (Example: John S. Jones)
2. Rate - Rate of Individual. (Example: OC)
3. Ship or Station - Command currently stationed. (Example: Officer Training Command Newport)
4. Date of Request - Date of Special Request Submission. (Example: 23 DEC 12)
5. Department/Division - Division of Command currently stationed. (Example: OCS)
6. Duty Section/Group - Class number.
7. Nature of Request - The reason of request.
8. Reason for Request - Clear, plain explanation for submission of Chit.
9. Signature of Applicant - Signature of Candidate.

The information regarding Leave (Days Requested, Address, etc.) is not applicable to Candidates while at OCS. In the event leave is desired, a Leave Request/Authorization Form will be used. Consult your Class Team for further guidance regarding instances for using Special Request Chits.

3 Jul 14

Instructions for OCS Report Chit

1. Candidate Name - Last, First, Middle Initial. (Example: Jones, John S)
2. Class # - Your current class of training. (Example: 07-13E)
3. Class of Offense - What Class the violation was (A, B, C). Reference OCR section 432 to determine. (Example: C)
4. Describe Nature of Offense - Simple, clear language describing the offense. (Example: Loss of military bearing.)
5. Time of Offense - What time the violation occurred. (Example: 0730)
6. Date of Offense - What date the violation occurred (Example: 09 DEC 12)
7. Place of Offense - Where the violation occurred. (Example: OCS Chow Hall)
8. Comments of person placing candidate on report.
9. Rank and Name of person placing candidate on report - Who placed you on report. (Example: Lieutenant Xxxxxx, USN)
10. Signature - Signature of person placing candidate on report.
11. Date - Date person placing candidate on report signed the Report Chit. (Example: 11 DEC 12)
12. Candidate Statement - Personal account of the violation. (Example: This Candidate lost his military bearing by smiling in the chow hall.)
13. Signature of candidate being placed on report.
14. Date - Date candidate on report signed the Report Chit.



Officer Candidate School Report Chit

Candidate Name (Last, First MI)	Class #	Class of Offense
Describe Nature of Offense		
Time of Offense	Date of Offense	Place of Offense
Comments of Person placing candidate on report (include recommended disciplinary actions based on class of offense)		
Rank and Name of Person placing candidate on report	Signature	Date
Candidate Statement (attach additional sheets only for Class "A" offenses)		
Signature of person being placed on report		Date

Chain of Command Comments and Recommendations	
Class Drill Instructor comments, recommendations and signature	Signature/ Date
Class Chief Petty Officer comments, recommendations and signature	Signature/ Date
Class Officer comments, recommendations or disciplinary actions approved	Signature/ Date

ADDITIONAL ROUTING

As Required

Chief Drill Instructor comments, recommendations and signature	Signature/ Date
Lead RDC's comments, recommendations and signature	Signature/ Date
OCS Lead Class Officer comments, recommendations and signature	Signature/ Date
Director, Officer Candidate School comments, recommendations, or disciplinary actions approved.	Signature/ Date

3 Jul 14

Instructions for Demerit Documentation Form

Upon assignment of Disciplinary Action, the following will be filled out:

Candidates will provide their signature and date the form upon being made aware of the disciplinary action.

The matrix on the form will be used to track the disciplinary action completed by date and demerits worked off.

Candidates must review the information already filled out on this form.

1. You have been awarded: How many demerits it has been determined you will be awarded as discipline. Due to: Reason for the assigned discipline.

To be worked off by performing the following: RPT or Marching Tours (at the discretion of the Awarding Authority).

2. To be served in accordance with the OCR from Earliest date Candidate is eligible to work off these demerits.

3 Jul 14

Instructions for OCR Change Recommendation

1. Date. Submission Date. (Example: 30 APR 10)
2. From. Candidate submitting change recommendation
(Example: OC John Jones)
3. Class. Class Candidate submitting change is currently training. (Example: 07-13F or H Class)
4. Revision Date - Current date stamped on page of OCR in question. (Example: 11 DEC 12)
5. Section/Chapter - Section and Chapter of OCR in question.
(Example: Chapter 5, Section 3)
6. Page. Page in the OCR discrepancy exists. (Example: 5-28)
7. Paragraph. Paragraph discrepancy exists. (Example: 532.d.(2))
8. Recommendation. Recommended change to include revision, addition, or deletion. Use clear, plain language.
9. Justification - Based upon what reference. Be specific with regards to the potential value in improving training.
10. Signature. Candidate Submitting Recommendation.
11. Title/Rank. Of Person Submitting Recommendation.
(Example: Officer Candidate, Candidate LTJG, Class Officer, Academics Instructor, etc.)

The remainder of the form is to be filled in by the OCS Lead Class Officer.

OCR CHANGE RECOMMENDATION

DATE _____

TO BE FILLED IN BY ORIGINATOR AND FORWARDED TO OCS LEAD CLASS OFFICER

FROM (originator)			Class
Revision Date	Section/ Chapter	Page	Paragraph
Recommendation (be specific)			

___ CHECK IF CONTINUED ON BACK

Justification

Signature	Title/Rank
-----------	------------

TO BE FILLED IN BY OCS Lead Class Officer (Return to Originator)

From	Date
To	

REFERENCE

(a) Your Change Recommendation Dated _____.

Your change recommendation dated _____ is acknowledged. It will be held for consideration by the review conference planned for _____.

Your change recommendation is reclassified URGENT and forwarded for approval to _____

_____ OCS Lead Class Officer

3 Jul 14

Instructions for Record of Counseling

The purpose of the Counseling Sheet is not in itself a means of discipline or punishment. Rather, it is to document a deficiency or discrepancy with a candidate or a candidate's behavior. The majority of the form will be filled out by the individual doing the counseling. There are several reasons a candidate may be counseled.

The portion requiring candidate activity is:

1. Read and comprehend the information and any amplifying remarks from the counselor.
2. The candidate may write freely on the block titled "Counselee's Comments."
3. Both Counselor and Counselee will sign the form at the bottom.

Page Intentionally Left Blank



OTCNINST 1530.6H
3 Jul 14

RECORD OF COUNSELING

Date: _____

PRIVACY ACT STATEMENT: The authority to request the following information is contained in 10 USC and DD 397. The date will be used to document quality force counseling actions not prescribed in other directives. When completed, the form may or may not become a source document to support administrative separation. Data is also releasable to higher headquarters officials when used to support administrative separation or UCMJ actions.

Completion of this form by a counselor is mandatory; however, disclosure of information or facts by the counselee is voluntary. Failure to disclose information or facts may not be in the counselee's best interest in the event administrative, disciplinary or separation action is subsequently deemed warranted by the counselee's commander.

NAME	GRADE	SSN
OCS CLASS	NAME/GRADE OF COUNSELOR	

REASON FOR COUNSELING

- | | |
|---|---|
| <input type="checkbox"/> PERFORMANCE | <input type="checkbox"/> PRIVATE INDEBTEDNESS |
| <input type="checkbox"/> PERSONAL BEHAVIOR | <input type="checkbox"/> SUPPORT OF DEPENDENTS |
| <input type="checkbox"/> OJT PROGRESS | <input type="checkbox"/> RESPONSIBILITIES |
| <input type="checkbox"/> SUBSTANDARD DRESS/APPEARANCE | <input type="checkbox"/> OTHER (SPECIFY)
_____ |

REASONS FOR COUNSELING (Give details, facts, specific dates, names, sequence of events.)

SOLUTION THAT COUNSELOR AND INDIVIDUAL DEVELOPED AND DISCUSSED TO OVERCOME THE PROBLEM(S) AND PRECLUDE FUTURE INVOLVEMENT. (Outline all solutions and indicate which one(s) the individual freely elected.)

(over)

OTHER AGENCIES INDIVIDUAL REFERRED TO (Family Services, CAAC, Chaplain,
Legal, etc.)

COUNSELEE'S COMMENTS

COUNSELEE'S SIGNATURE

COUNSELOR'S SIGNATURE

Instructions for Leave Request/Authorization Form

The Leave Request/Authorization Form, also known as a Leave Chit, is used when a Leave of Absence from one's command is desired and requested.

To properly fill out the Leave Chit, ensure the following blocks are filled in completely:

1. Date of Request - Day of Chit Submission. (Example: 12 DEC 12)
3. SSN - Last 4 of Social Security Number. (Example: XXX-XX-6789)
4. Name - Last, First, Middle Initial (Example: Jones, John S.)
5. Pay Grade - Pay Grade of Individual (Example: O-3, E-7, OC/E-5, etc.)
6. Ship or Station - Command currently stationed. (Example: Officer Training Command Newport)
7. Dept/Div - Division of Command currently stationed. (Example: OCS)
8. Duty Section - For OCS, your class number. (Example: Class 07-13E)
9. Duty Phone - Phone associated with Command Duty Officer. (Example: 401.862.4321)
10. Type of Leave - Check the block of the type of leave requested.
11. FOR USE OUTUS ONLY - Leave Blank.
12. Mode of Travel - Check the means of travel to leave destination.
13. Days Requested - Total days of leave requested. (Example: 3) **NOTE: This is calculated based on time of departure and return from leave. Consult your Class Team for guidance regarding calculating requested days.**
14. From - Hour and Date of Request to Depart on Leave (Example: 1600, 11 DEC 12)

3 Jul 14

15. To - Hour and Date of Request to Depart on Leave (Example:
0500 11 DEC 12)

16. Normal Working Hours - Hours typically associated with the
OCS Workday. (Example: From: 0500 To: 1600)

17. Leave Balance - How many days currently on credit.
(Example: 5 days as of 11 DEC 12) Consult your class team.

18. Leave Used This Fiscal Year - How many days used since the
start of the current Fiscal Year (1 OCT). (Example: 2)
Consult your class team.

19. Leave Phone - Telephone Number at Destination of Leave.
(Example: (123) 456-7890))

20. Leave Address - Address at Destination of Leave.

21. Signature of Applicant - Signature of Candidate.

22. Comments/Remarks - Any explanation of reason for request in
clear, plain language.

3 Jul 14

LEAVE REQUEST/AUTHORIZATION
NAVCOMPT FORM 3065 (3PT) (REV. 2-83)

INSTRUCTIONS FOR COMPLETING THIS FORM
 ARE ON THE REVERSE OF PART 3.

**SEE REVERSE FOR
 PRIVACY ACT
 STATEMENT**

1. DATE OF REQUEST		2. FOR ADMIN. USE ONLY APPROVAL OF THIS LEAVE IS NOT VALID WITHOUT CONTROL NO.		LEAVE CONTROL NO.	
3. SSN		4. NAME (Last, First, MI)			5. PAY GRADE
6. SHIP/STATION		7. DEPT/DIV	8. DUTY SECTION	9. DUTY PHONE	
10. TYPE LEAVE <input type="checkbox"/> REGULAR <input type="checkbox"/> SICK <input type="checkbox"/> EMERGENCY <input type="checkbox"/> SEPARATION <input type="checkbox"/> RETIREMENT <input type="checkbox"/> OTHER _____			FOR USE OUTUS ONLY		12. MODE OF TRAVEL
			11a. Leaving Area of PERMDUSTA <input type="checkbox"/> YES <input type="checkbox"/> NO	<input type="checkbox"/> AIR <input type="checkbox"/> BUS	
			11b. Taking Leave INCONUS <input type="checkbox"/> YES <input type="checkbox"/> NO	<input type="checkbox"/> CAR <input type="checkbox"/> TRAIN	
13. DAYS REQUESTED	14. FROM (Hour, Date) (YYMMDD)	15. TO (Hour, Date) (YYMMDD)		16. NORMAL WORKING HOURS DAY OF DEPARTURE:	
17. LEAVE BALANCE DAYS AS OF	18. LEAVE USED THIS FY	19. LEAVE PHONE		FROM: 0700 TO: 1600	
				DAY OF RETURN:	
				FROM: 0700 TO: 1600	
20. LEAVE ADDRESS				21. RATION STATUS (Enlisted) <input type="checkbox"/> COMMUTED RATIONS (COMRATS) <input type="checkbox"/> Meal Pass No. _____ Entitled to EDF meals except during periods of leave	

I CERTIFY THAT I HAVE SUFFICIENT FUNDS TO COVER THE COST OF ROUND TRIP TRAVEL. I UNDERSTAND THAT SHOULD ANY PORTION OF THIS LEAVE, IF APPROVED, RESULT IN MY TAKING MORE LEAVE THAN I CAN EARN ON MY CURRENT UN-EXTENDED ENLISTMENT OR CURRENT ACTIVE DUTY OBLIGATION, MY PAY WILL BE CHECKED FOR SUCH EXCESS LEAVE.

22. SIGNATURE OF APPLICANT _____

RECOMMENDED				DATE	
<input type="checkbox"/> YES	<input type="checkbox"/> NO				
<input type="checkbox"/> YES	<input type="checkbox"/> NO				
<input type="checkbox"/> YES	<input type="checkbox"/> NO				
<input type="checkbox"/> YES	<input type="checkbox"/> NO				
23. APPROVED <input type="checkbox"/>	DISAPPROVED <input type="checkbox"/>				

24. COMMENTS/REMARKS _____

25. SHIP OR STATION (Including telegraphic address) Officer Training Command Newport Officer Candidate School Newport, RI 02841 COMM: (841) 862-4321		26. REPORT ON EXPIRATION OF LEAVE TO (if other than block 25)	
--	--	---	--

DEPARTED ON LEAVE		RETURNED FROM LEAVE		GRANTED EXTENSION OF LEAVE ENDING	
27a. HOUR	27b. DATE (*YYMMDD)	28a. HOUR	28b. DATE (*YYMMDD)	29a. HOUR	29b. DATE (*YYMMDD)
27c. OOD'S SIGNATURE		28c. OOD'S SIGNATURE		29c. OOD'S SIGNATURE	

IN CONSIDERATION OF THE MEMBER'S COMPLETION OF A FULL WORKDAY (AS DEFINED IN MILPERSMAN, NAVPERS 15560) ON THE DAYS OF DEPARTURE AND RETURN, THE INCLUSIVE DAYS SHOWN ARE CORRECT AND PROPER FOR CHARGING AS LEAVE.		30. INCLUSIVE LEAVE PERIOD TO BE CHARGED		FIRST: (YY) (MM) (DD)		LAST: (YY) (MM) (DD)		31. NO. OF DAYS	
---	--	--	--	-----------------------	--	----------------------	--	-----------------	--

I CERTIFY THAT THE ABOVE IS CORRECT AND PROPER TO THE BEST OF MY KNOWLEDGE.		32. CERTIFYING OFFICER'S TYPED NAME/RANK/TITLE			33. CERTIFYING OFFICER'S SIGNATURE		
---	--	--	--	--	------------------------------------	--	--

FORWARD THIS COPY TO PERSONNEL OFFICE VIA COMMAND ONLY ON COMPLETION OF LEAVE.

INSTRUCTIONS FOR COMPLETING THE LEAVE REQUEST PORTION OF THIS FORM

1. Completion of this form must be in ballpoint or typewriter. The form must be completed in triplicate with all copies legible.
2. Print or type the appropriate date in block 1 and 3 through 21. Leave block 2 blank.
3. When completing blocks 14 and 15, follow these rules:
 - a. Block 14 - The hour for starting leave may not be prior to the end of your normal workaday if leave starts on a workday. Of leave starts on a non-workday, the starting hour may be 0001 if not contrary to command policy.
 - b. Block 15 - The hour for ending leave may not be later than the beginning of your normal workday if the day of return is a workday. If leave ends on a non-workday the ending hour may be 2400 if not contrary to command policy.
4. Block 16 requires the following information:
 - Normal working hours for day of departure
 - Normal working hours for day of return
 - If day of departure is not a workday, enter "NONE"
5. Information required in blocks 17 and 18 may be obtained from Block 59 of your latest Leave and Earnings-Statement or you're your activity's Commanding Officer's Leave Listing.
6. You are advised that you must immediately return your original leave authorization to the appropriate office designated by your command upon return from leave.

PRIVACY ACT STATEMENT

FOR

NAVCOMPT 3065

LEAVE REQUEST/AUTHORIZATION

This statement is provided in compliance with the provisions of the Privacy Act of 1974 (PL 93-579), which require that Federal agencies must inform individuals who are requested to furnish information about themselves as to the following facts concerning the information requested.

1. **AUTHORITY:** Title 10 and 37 USC
2. **PRINCIPAL PURPOSE(S):** To authorize military leave of absence.
3. **ROUTINE USE(S):** To deduct leave taken from member's accrued leave balances. To pay leave rations to enlisted members.
4. **MANDATORY OR VOLUNTARY DISCLOSURE:** voluntary. If the member does not request a specific period of leave or furnish his leave address, leave is not granted.

OFFICER CANDIDATE FITNESS REPORT & COUNSELING RECORD

1. Name (Last, First, MI Suffix)		2. Class		3. Desig		4. NRD	
5. OCS <input type="checkbox"/> ODS <input type="checkbox"/> CWO/LDO <input type="checkbox"/> DCO <input type="checkbox"/> NSI <input type="checkbox"/>		6. UIC		7. Ship/Station		8. Re Eval (Y/N)	
9. Date Reported		Occasion for Report					
10. 1 st Phase <input type="checkbox"/>		11. 2 nd Phase <input type="checkbox"/>		12. Special (H-Class, MEDHOLD) <input type="checkbox"/>		13. Other <input type="checkbox"/>	
14. From:		15. To:					
16. Total Demerits Rcvd		Current Averages		20. RLP		21. Candidate Billet	
17. MTT:		18. Academic:		19. PRT:			
22. Reporting Senior (Last, FI M)				23. Desig		24. Title	
25. Class achievements.							
26. Primary duties. (Enter primary duty abbreviation in box.) <div style="border: 1px solid black; height: 20px; width: 100%;"></div>							
PERFORMANCE TRAITS: 1.0 - Below standards/not progressing or UNSAT in any one standard; 2.0 - Does not yet meet all 3.0 standards; 3.0 - Meets all 3.0 standards; 4.0 - Exceeds most 3.0 standards; 5.0 - Meets overall criteria and most of the specific standards for 5.0. Standards are not all inclusive. Traits of 3.0 and below, require supporting comments in block 35.							
PERFORMANCE TRAITS	1.0* Below Standards	2.0 Pro- gressing	3.0 Meets Standards	4.0 Above Standards	5.0* Greatly Exceeds Standards		
27. HONEST / INTEGRITY: Consistency of ethics, values and actions, adherence to Navy Core Values. NOB <input type="checkbox"/>	- Does not hold oneself to the ethical standards expected of a Naval Officer. - Fails to demonstrate consistent uprightness of character and soundness or moral principles. -Lies or deceives - Fails to live up to one or more Navy Core Values: HONOR, COURAGE, COMMITMENT	- - -	- Consistently displays ethical principles. - Displays uprightness of character and soundness of moral principles. -Trustworthy, ethical and honest - Always lives up to Navy Core Values: HONOR, COURAGE, COMMITMENT	- - -	- Admired for exemplary display of ethical principles. - Encourages others to strive for uprightness of character and soundness of moral principles. - Leads with an uncompromising code of integrity. - Exemplifies Navy Core Values: HONOR, COURAGE, COMMITMENT.	<input type="checkbox"/>	<input type="checkbox"/>
28. WORK ETHIC: Value based, hard work and dedication. NOB <input type="checkbox"/>	- Needs excessive supervision. - Does not accomplish assigned tasks. - Product frequently needs rework. - Gives minimal effort. - Wasteful of resources.	- - -	- Needs little supervision. - Shows diligence in accomplishing assigned tasks. - Gives strong effort. - Uses resources efficiently.	- - -	- Needs no supervision. - Goal oriented. - Always produces exceptional work. No rework required. - Seeks out task opportunities without being asked. - Gives maximum effort. - Maximizes resources.	<input type="checkbox"/>	<input type="checkbox"/>
29. INITIATIVE: Ability and tendency to start an action. NOB <input type="checkbox"/>	- Displays procrastination. - Lacks personal injury.	- -	- Strives towards goal oriented action. - Shows personal energy.	- -	- Takes action in absence of orders according to the commanders intent. - Instills energy and enthusiasm	<input type="checkbox"/>	<input type="checkbox"/>
30. MILITARY BEARING/ CHARACTER: Appearance, conduct, physical fitness NOB <input type="checkbox"/>	- Consistently unsatisfactory appearance. - Poor self-control; conduct resulting in disciplinary action. - Unable to meet one or more physical readiness standards.	- - -	- Excellent personal appearance. - Excellent conduct, conscientiously complies with regulations. - Complies with physical readiness program, within all standards.	- - -	- Exemplary personal appearance. - Model of conduct, on and off duty. - Excellent or outstanding PRT. A leader in physical readiness.	<input type="checkbox"/>	<input type="checkbox"/>
31. DEPENDABILITY: Worthy of trust NOB <input type="checkbox"/>	- Needs prodding to attain qualification or finish job. - Prioritizes poorly. - Avoids responsibility. - Lacks ability to manage under stress.	- - -	- Productive and motivated. Completes tasks and qualifications fully and on time. - Plans/prioritizes effectively. - Reliable, dependable, willingly accepts responsibility. - Performs well under stress.	- - -	- Energetic self-starter. Completes tasks early; far better than expected. - Plans/prioritizes wisely and with exceptional foresight. - Seeks extra responsibility and takes on the hardest jobs. - Inspires others to persevere through challenges.	<input type="checkbox"/>	<input type="checkbox"/>

OFFICER CANDIDATE FITNESS REPORT & COUNSELING RECORD

1. Name (Last, First, MI Suffix)			2. Class		3. Desig		4. NRD	
PERFORMANCE TRAITS	1.0* Below Standards	2.0 Pro- gressing	3.0 Meets Standards		4.0 Above Standards	5.0* Greatly Exceeds Standards		
32. TEAMWORK: Contributions to team building and team results. NOB <input type="checkbox"/>	- Creates conflict, unwilling to work with others, puts self above team. - Fails to understand team goals and teamwork techniques. - Does not take direction well.	- - -	- Reinforces others' efforts, meets commitments to team. - Understands goals, employs good teamwork techniques. - Accepts and offers team direction.		- - -	- Team builder, inspires cooperation and progress. - Focuses goals and techniques for teams. - The best at accepting and offering team direction.		
33. LEADERSHIP: Organizing, motivating and developing others to accomplish goals. NOB <input type="checkbox"/>	- Fails to motivate, train or develop subordinates. - Fails to organize, creates problems for subordinates. - Does not set or achieve goals relevant to command mission. - Inadequate communication. - Tolerates hazards or unsafe practices. - Does not attend to welfare of subordinates.	- - - - -	- Effectively motivates, trains and develops subordinates. - Organizes successfully, solves problems as they occur. - Sets/achieves useful, realistic goals which support command mission. - Clear, timely communicator. - Ensures safety of personnel and equipment. - Routinely considers subordinates' personal and professional welfare.		- - - - -	- Inspiring motivator and trainer, consistently builds winners. - Superb organizer, great foresight, gets ahead of problems. - Leadership achievements significantly further command mission. - Exceptional communicator. - Makes subordinates safety-conscious, has top safety record. - Constantly improves the personal and professional lives of others.		
34. I recommend screening this individual for next OCS milestone(s) as follows: (maximum of two) Recommendations may be for competitive billet selection.								
35. COMMENTS ON PERFORMANCE. *All marks below 3.0 in specifically substantiated in comments. Candidate with overall Member Trait Average below a 3.0 must have a documented history of performance. Font must be 10 or 12 pitch (10 to 12 point) only. Use upper and lower case.								
Promotion Recommendation	NOB	Significant Problems	Progressing	Promotable	Must Promote	Early Promote	38. Retention: Not Recommended <input type="checkbox"/> Recommended <input type="checkbox"/>	
36. INDIVIDUAL							39. Reporting Senior Address	
37. SUMMARY	X							
40. Class Rank:						41. Signature of Reporting Senior (Class Officer)		
Member Trait Average:			Summary Class Average:			Date:		
42. Signature of Individual Evaluated. "I have seen this report, been apprised of my performance, and understand my right to submit a statement." I intend to submit a statement. <input type="checkbox"/> I do not intend to submit a statement. <input type="checkbox"/> Date:						43. Typed name, grade, command of Reporting Senior (ClassOfficer) Date:		

OTCNINST 1530.6G